

FRONT VIEW

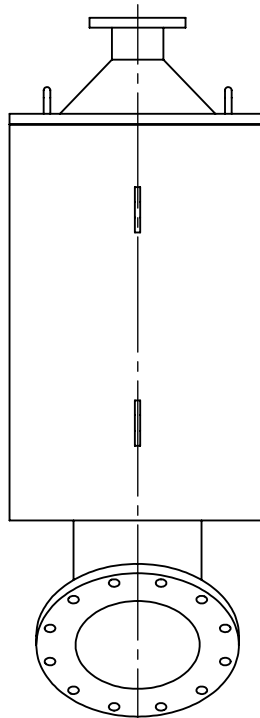

BACK VIEW

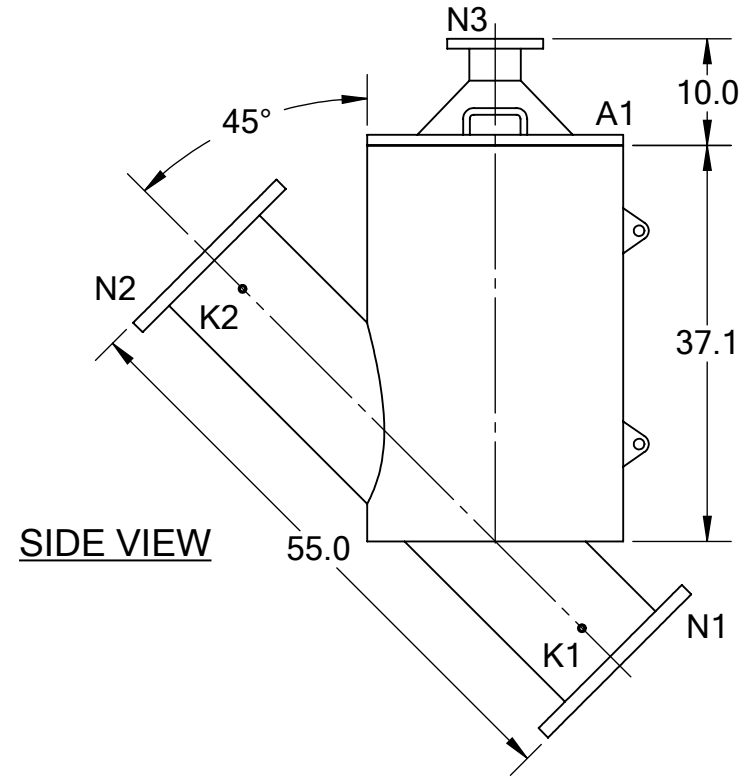

SIDE VIEW

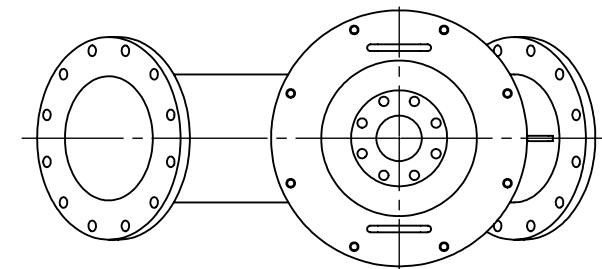

TOP VIEW

REVISIONS				
REV.	ZONE	DESCRIPTION	DATE	INITIAL

TECHNICAL DATA

FLOW RATE	MAX. 6,000 GPM (1,363 m ³ /hr)
SCREEN SIZE	___ MICRON
SCREEN AREA	12.4 SQ. FEET
DESIGN TEMPERATURE	160 °F
DESIGN PRESSURE	100 PSI
EMPTY WEIGHT	~675 LBS.
FULL WEIGHT	~1,650 LBS.

NOZZLE	CONNECTION	TYPE	SIZE	RATING
A1	SERVICE PORT	FLANGED	24"	
K1	HIGH PRESSURE CONN.	THREADED	1/4" NPT(2)	
K2	LOW PRESSURE CONN.	THREADED	1/4" NPT(2)	
N1	INLET	FLANGED	12" ASA	CLASS #150 F.F.S.O.
N2	OUTLET	FLANGED	12" ASA	CLASS #150 F.F.S.O.
N3	FLUSH OUTLET	FLANGED	4" ASA	CLASS #150 F.F.S.O.

TOLERANCES (UNLESS OTHERWISE SPECIFIED)	
FRAC. ±1/16	ANGLE ±1°
.X ±.1	
.XX ±.05	
.XXX ±.010	
MATERIAL:	SST
DRAWN BY:	M. SERRANO
DATE:	10/08/18
SCALE:	1:18
SHEET:	1 OF 1



TITLE: CSF12-XL FILTER, CUT DRAWING	
DRAWING NUMBER	REV
CSF-12XL-CUT-01	N/A