

FRONT VIEW

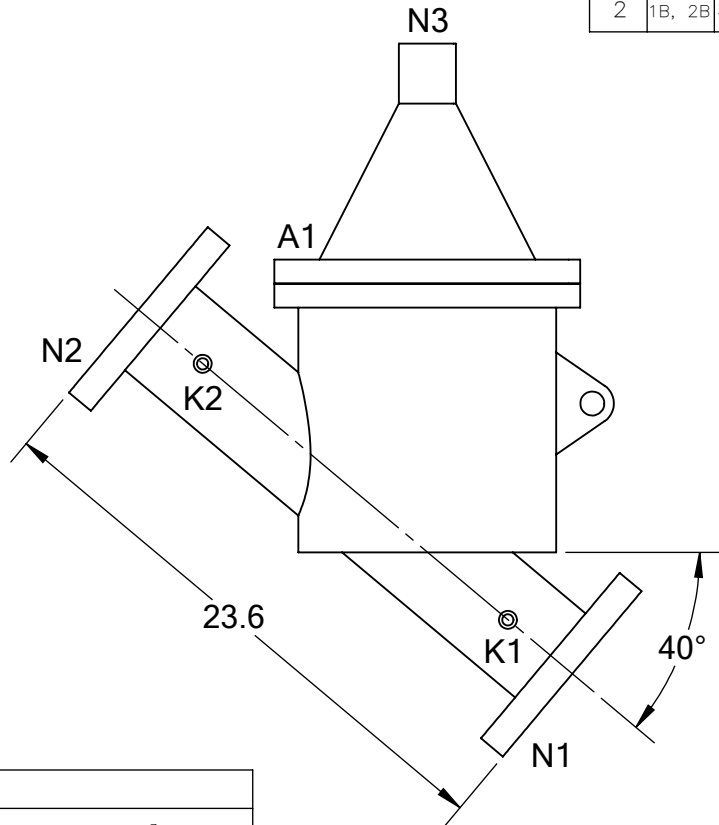

SIDE VIEW

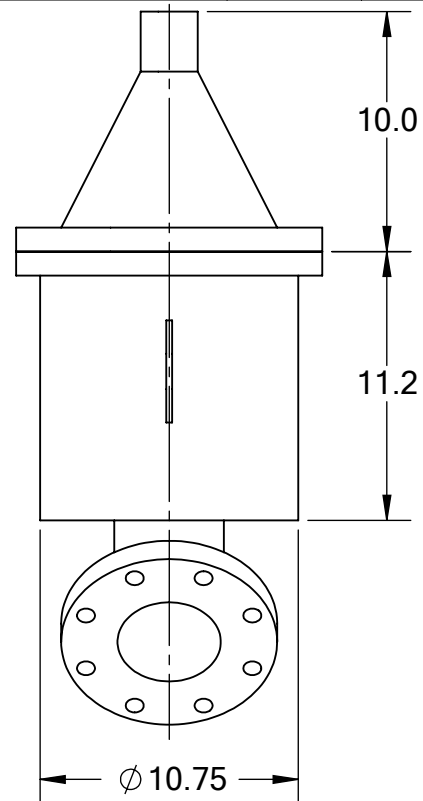

BACK VIEW

REVISIONS				
REV.	ZONE	DESCRIPTION	DATE	INITIAL
1	ALL	ROTATED FLANGE HOLES 22.5°, UPDATED WITH MOST CURRENT BODY.	10/26/12	S.P.
2	1B, 2B	CHANGED "WORKING" TO "DESIGN" & 200°F TO 160°F IN TECHNICAL DATA TABLE.	04/09/13	S.P.

TECHNICAL DATA

FLOW RATE	MAX. 500 GPM (114 m ³ /hr)
SCREEN SIZE	___ MICRON
SCREEN AREA	2.0 SQ. FEET
DESIGN TEMPERATURE	160 °F
DESIGN PRESSURE	150 PSI
EMPTY WEIGHT	~120 LBS.
FULL WEIGHT	~170 LBS.

NOZZLE	CONNECTION	TYPE	SIZE	RATING
A1	SERVICE PORT	FLANGED	12.75"	
K1	HIGH PRESSURE CONN.	THREADED	1/4" NPT(2)	
K2	LOW PRESSURE CONN.	THREADED	1/4" NPT(2)	
N1	INLET	FLANGED	4" ASA	CLASS #150 F.F.S.O.
N2	OUTLET	FLANGED	4" ASA	CLASS #150 F.F.S.O.
N3	FLUSH OUTLET	THREADED	2" NPT	

TOLERANCES (UNLESS OTHERWISE SPECIFIED)	
FRAC. ±1/16	ANGLE ±1°
.X ±.1	
.XX ±.05	
.XXX ±.010	
MATERIAL: SST	
DRAWN BY: S. PERKINSON	
DATE: 07/01/11	
SCALE: 1:8	SHEET: 1 OF 1



TITLE: CSF4 FILTER, CUT DRAWING	
DRAWING NUMBER	REV
CSF-4-CUT-01	2