

FRONT VIEW

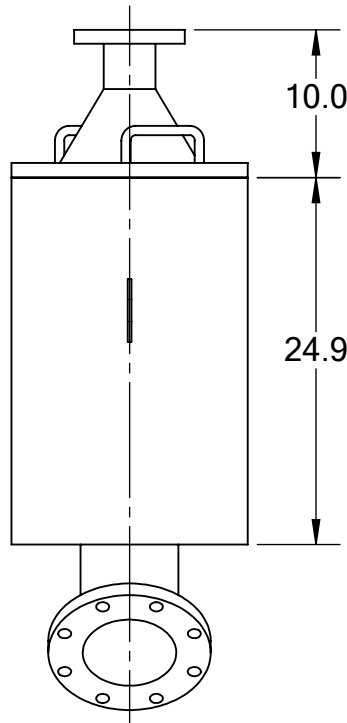

BACK VIEW

REVISIONS				
REV.	ZONE	DESCRIPTION	DATE	INITIAL

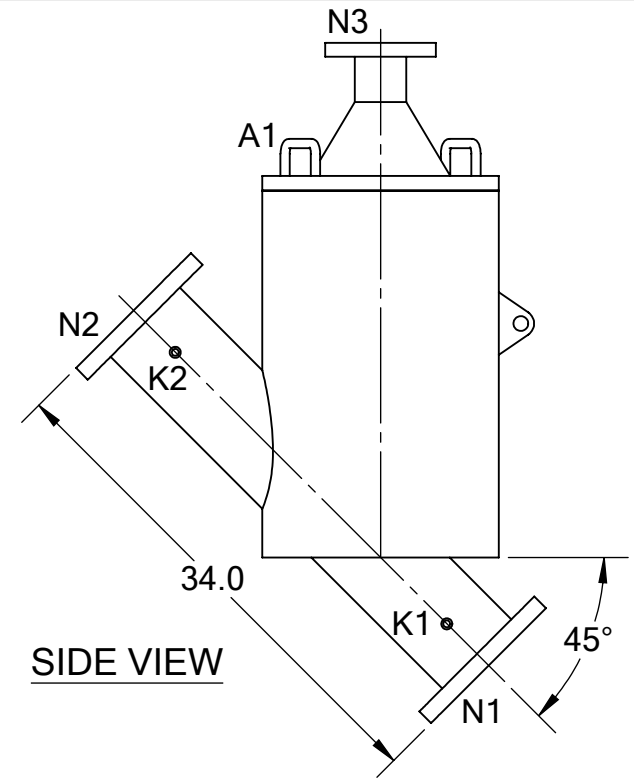

SIDE VIEW

TOP VIEW

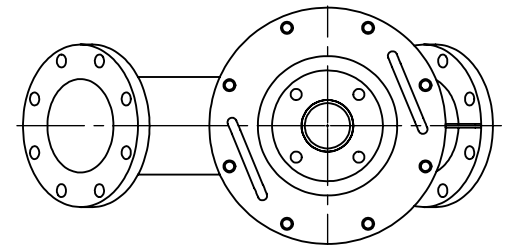

TECHNICAL DATA

FLOW RATE	MAX. 1,500 GPM (340 m ³ /hr)
SCREEN SIZE	____ MICRON
SCREEN AREA	5.6 SQ. FEET
DESIGN TEMPERATURE	160 °F
DESIGN PRESSURE	150 PSI
EMPTY WEIGHT	~250 LBS.
FULL WEIGHT	~450 LBS.

NOZZLE	CONNECTION	TYPE	SIZE	RATING
A1	SERVICE PORT	FLANGED	16"	
K1	HIGH PRESSURE CONN.	THREADED	1/4" NPT(2)	
K2	LOW PRESSURE CONN.	THREADED	1/4" NPT(2)	
N1	INLET	FLANGED	6" ASA	CLASS #150 F.F.S.O.
N2	OUTLET	FLANGED	6" ASA	CLASS #150 F.F.S.O.
N3	FLUSH OUTLET	FLANGED	3" ASA	CLASS #150 F.F.S.O.

TOLERANCES (UNLESS OTHERWISE SPECIFIED)	
FRAC. ±1/16	ANGLE ±1°
.X ±.1	
.XX ±.05	
.XXX ±.010	
MATERIAL: SST	
DRAWN BY: S. PERKINSON	
DATE: 07/23/2015	
SCALE: 1:13	SHEET: 1 OF 1



TITLE: CSF6-S FILTER WITH 3" FLANGED FLUSH OUTLET, CUT DRAWING	
DRAWING NUMBER	REV
CSF-6S-CUT-01	N/A