

SIDE VIEW

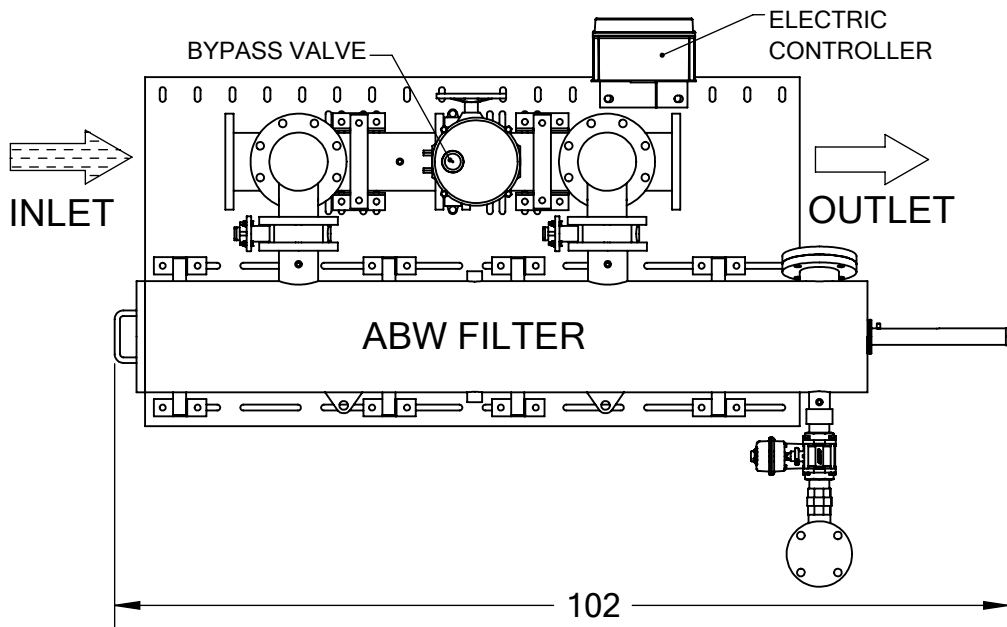

TOP VIEW

REVISIONS				
REV.	ZONE	DESCRIPTION	DATE	INITIAL

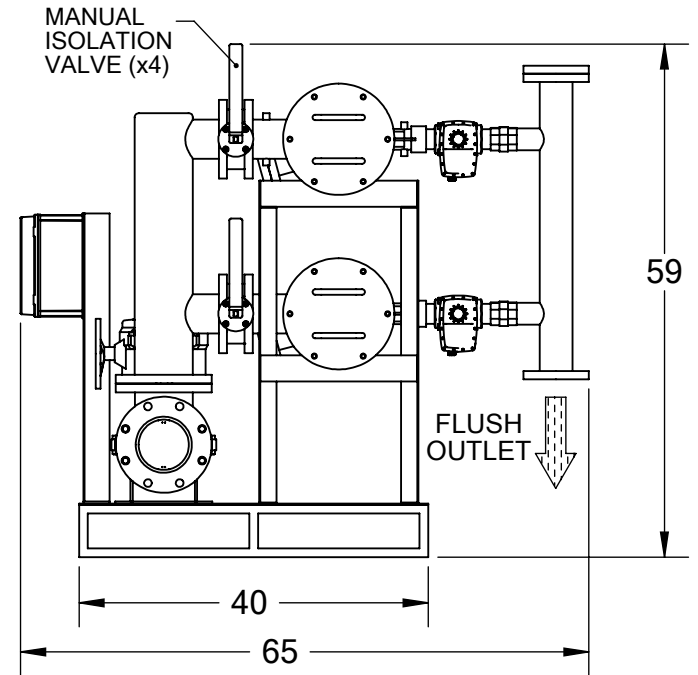

FRONT VIEW

- NOTES:
1. MINI-FILTERS, D/P SWITCH, HARDWARE, HYDRAULIC & ELECTRICAL CONNECTIONS NOT SHOWN.
 2. ACTUAL VALVES USED MAY DIFFER SLIGHTLY AND BE ORIENTED DIFFERENTLY.
 3. ELECTRIC CONTROLLER MAY BE PLACED ELSEWHERE ON SKID BASE.
 4. DIMENSIONS ARE APPROXIMATES AND MAY VARY SLIGHTLY DEPENDING ON FILTER MODEL USED.
 5. NUMBER OF FILTER BRACES MAY VARY.
 6. SERVICE AREA NOT TO SCALE.

TOLERANCES (UNLESS OTHERWISE SPECIFIED)

FRAC. $\pm 1/16$
 .X $\pm .1$
 .XX $\pm .05$
 .XXX $\pm .010$

ANGLE $\pm 1^\circ$

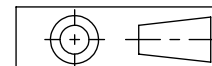

MATERIAL: VARIES

DRAWN BY: S. PERKINSON

DATE: 04/06/2017

SCALE: 1:22

SHEET: 1 OF 1

TITLE: 2x ABW FILTERS ON SKID UNIT (LAYERED), LAYOUT DRAWING, (4-XLP, 6-XLP & 8-LP MODELS)

DRAWING NUMBER: SKID-2ABW-LAYERED-1
REV: N/A