

REVISIONS				
REV.	ZONE	DESCRIPTION	DATE	INITIAL

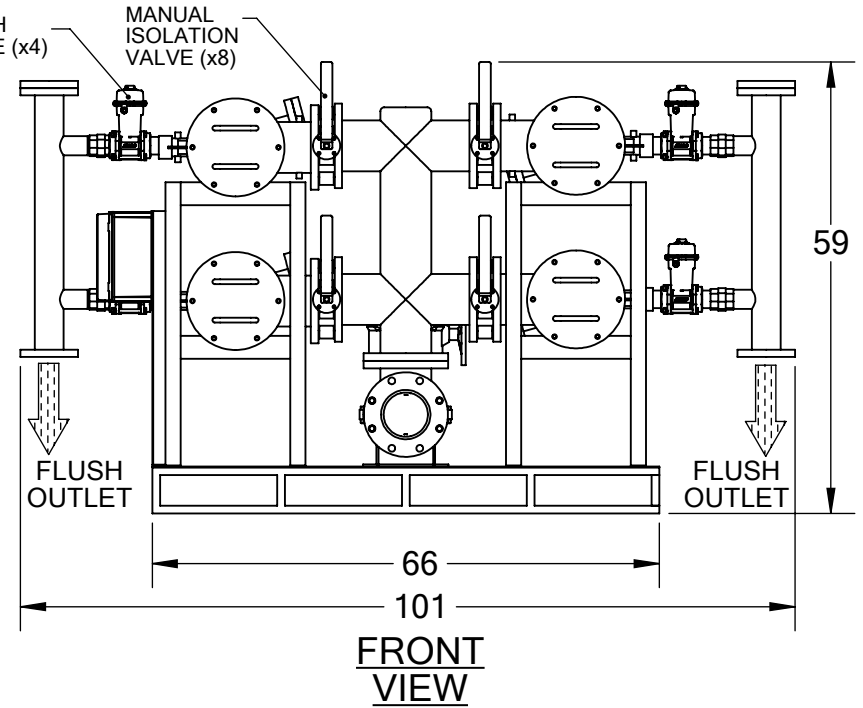

SIDE VIEW

FRONT VIEW

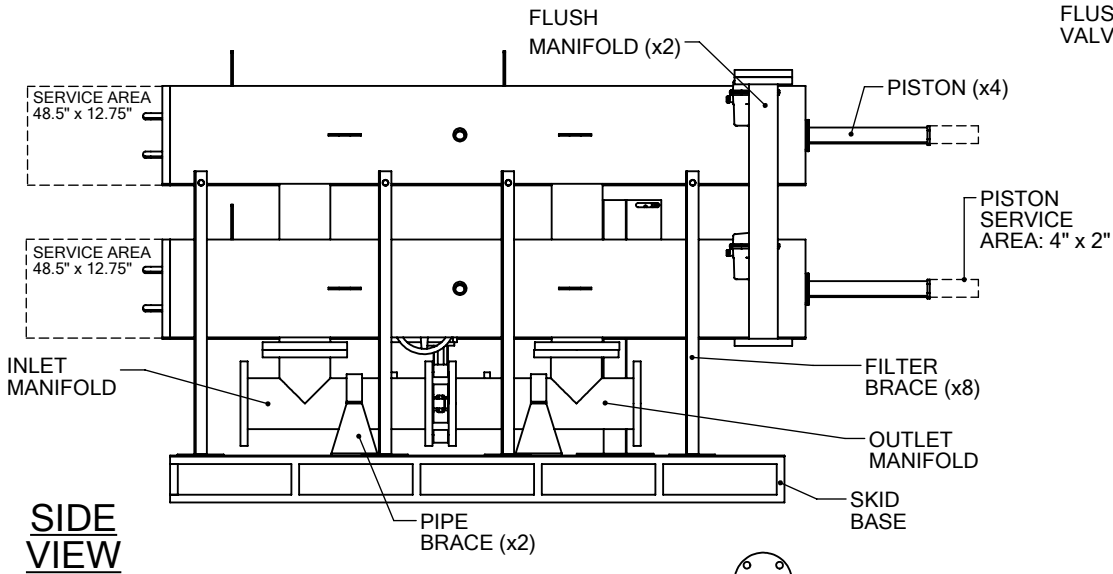
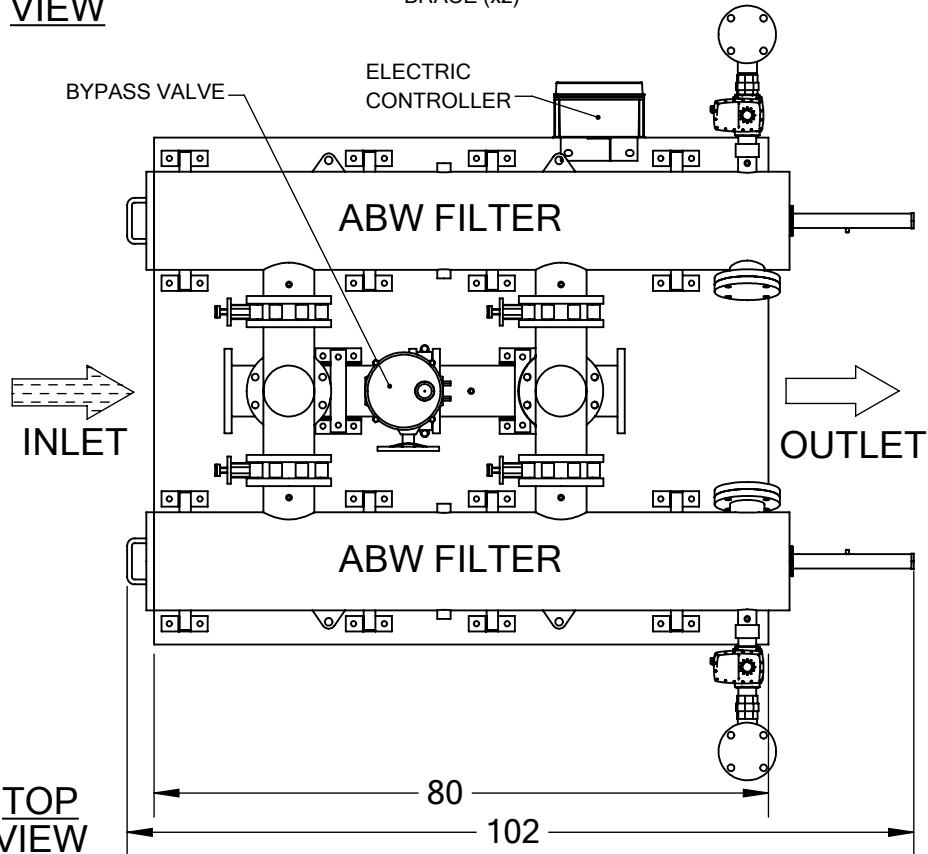

TOP VIEW

- NOTES:
1. MINI-FILTERS, D/P SWITCH, HARDWARE, HYDRAULIC & ELECTRICAL CONNECTIONS NOT SHOWN.
 2. ELECTRIC CONTROLLER MAY BE MOUNTED ELSEWHERE ON SKID BASE & VARY IN SIZE.
 3. ACTUAL VALVES & CONNECTING PIPES USED MAY DIFFER SLIGHTLY AND BE ORIENTED DIFFERENTLY.
 4. DIMENSIONS ARE APPROXIMATES AND MAY VARY SLIGHTLY.
 5. NUMBER OF BRACES MAY VARY.
 6. SERVICE AREAS NOT TO SCALE.

TOLERANCES (UNLESS OTHERWISE SPECIFIED)

FRAC. $\pm 1/16$
 .X $\pm .1$
 .XX $\pm .05$
 .XXX $\pm .010$

ANGLE $\pm 1^\circ$

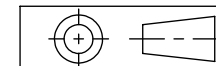

MATERIAL: VARIES

DRAWN BY: S. PERKINSON

DATE: 01/24/2018

SCALE: 1:25 **SHEET:** 1 OF 1

TITLE: 4x ABW FILTERS ON SKID UNIT (LAYERED), LAYOUT DRAWING, (4-XLP, 6-XLP, & 8-LP' MODELS)

DRAWING NUMBER SKID-4ABW-LAYERED-1
REV N/A