

1 2 3 4 5 6 7 8

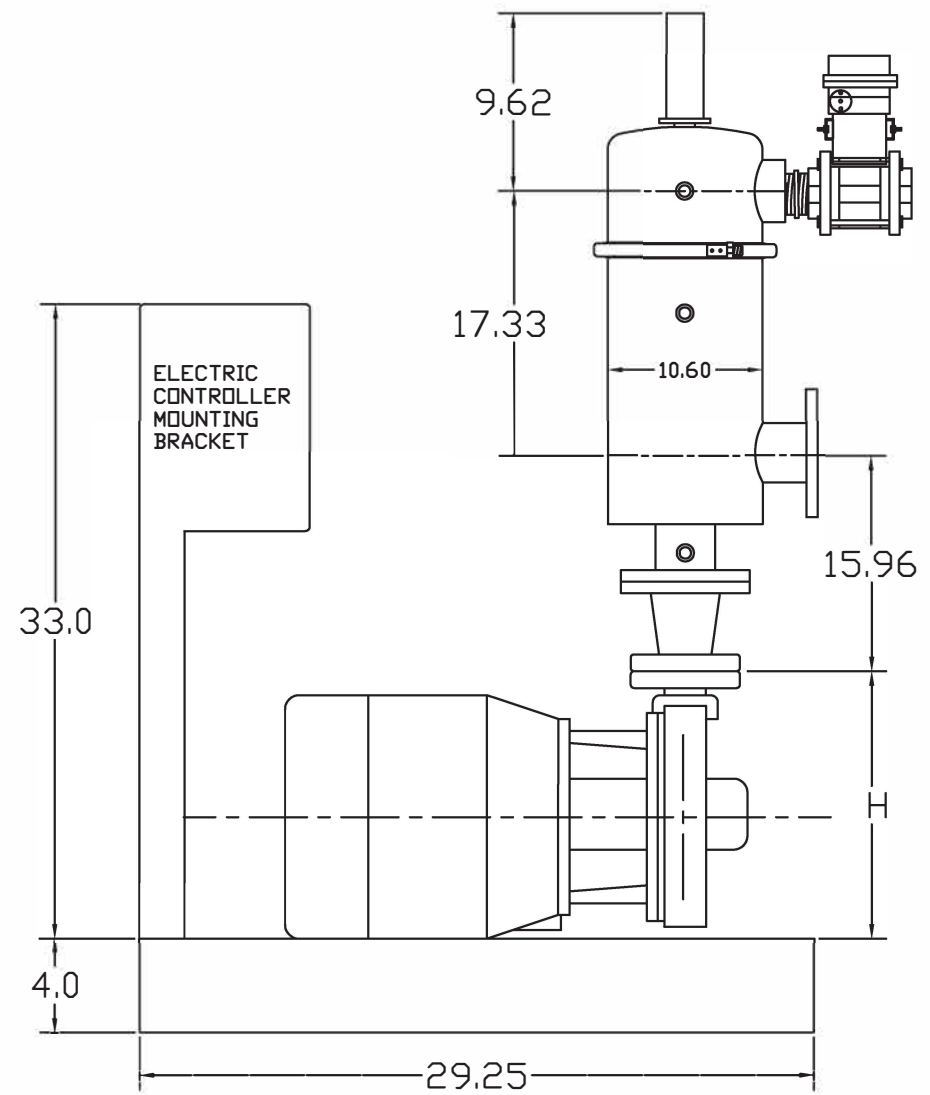
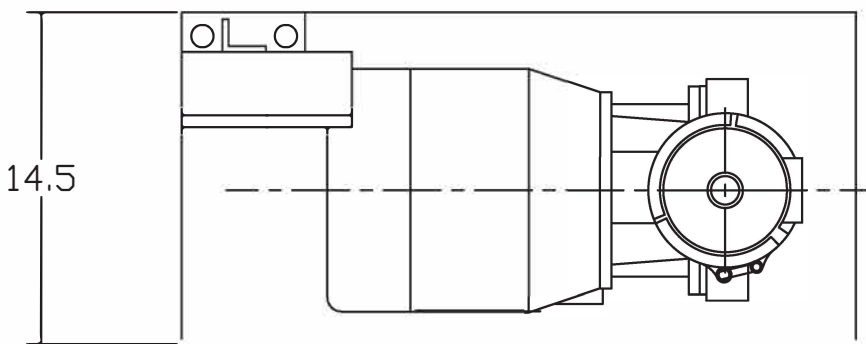

ELECTRIC
CONTROLLER
MOUNTING
BRACKET

REVISIONS				
REV	ZONE	DESCRIPTION	DATE	APPROVED
1	A7, A8	ADDED MTF2-XL TO TITLE & RENUMBERED DRAWING.	12/17/10	S.P.
2	ALL	CHANGED "WORKING" PRESS/TEMP TO "DESIGN" PRESS/TEMP ADDED AN EBV TO THE FLUSH OUTLET LABELED THE CONTROLLER BRACKET	5/13/13	J.K.

TECHNICAL DATA		Pump Dimension H	
Flow Rate	Max. 500 GPM	h/p	H
Screen Size	5-800 Micron	5	9.9375
Screen Area	3.0 Sq.Ft.	7.5	11.5
Design Temp.	160°F	10	11.375
Design Pressure	150 PSI	15	11.375
Weight	320 lbs.		

UNLESS OTHERWISE SPECIFIED
DIMENSIONS ARE IN INCHES
TOLERANCES
DECIMALS ANGULAR
.XX ± .05 ± 0.5 DEG.
.XXX ± .01



DRAWN Daniel Stenberg	7-19-07	MTF 2-XL, 3-L, & 4-L FILTER w/ SKID UNIT		
CHECKED		SIZE A	DWG NO. MTF-2XL-3L-4L-SKID-01	REV 2
DESIGN		NOT TO SCALE		SHEET 1 OF 1