

REVISIONS				
ZONE	REV	DESCRIPTION	DATE	APPROVED

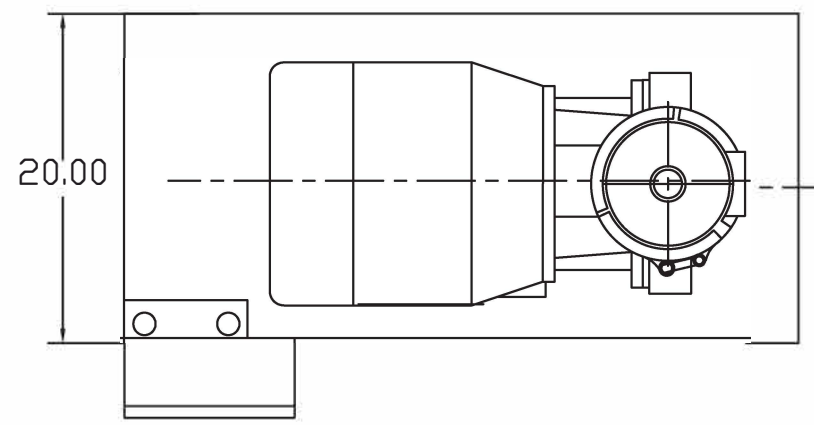

FLOWRATE: MAX 100GPM
 DESIGN PRESS: 150PSI
 DESIGN TEMP: 160°F
 PUMP POWER: 3HP
 WEIGHT: 150LBS

UNLESS OTHERWISE SPECIFIED
 DIMENSIONS ARE IN INCHES
 TOLERANCES
 DECIMALS ANGULAR
 .XX ± .05 ± 0.5 DEG.
 .XXX ± .01

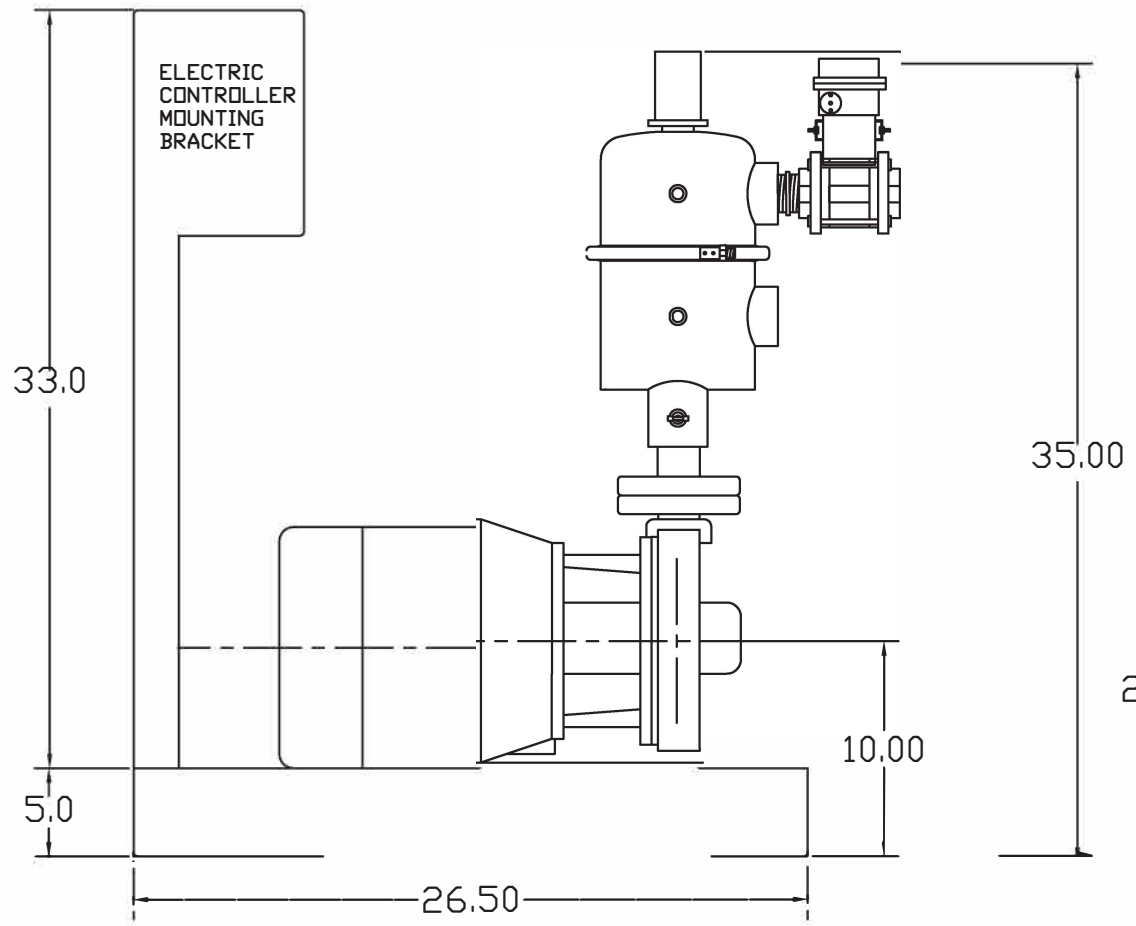

DRAWN	JORDEN KAWAMOTO	DATE	05/13/13	TITLE	MTF2 FILTER W/ EBV, GB6, AND ELECTRIC MOTOR MOUNTED ON SKID UNIT	
CHECKED				SIZE	DWG NO.	REV
DESIGN				A	SKID-MTF2-CUT-01	N/A
				SCALE	1:6	SHEET OF