

REVISIONS				
ZONE	REV	DESCRIPTION	DATE	APPROVED

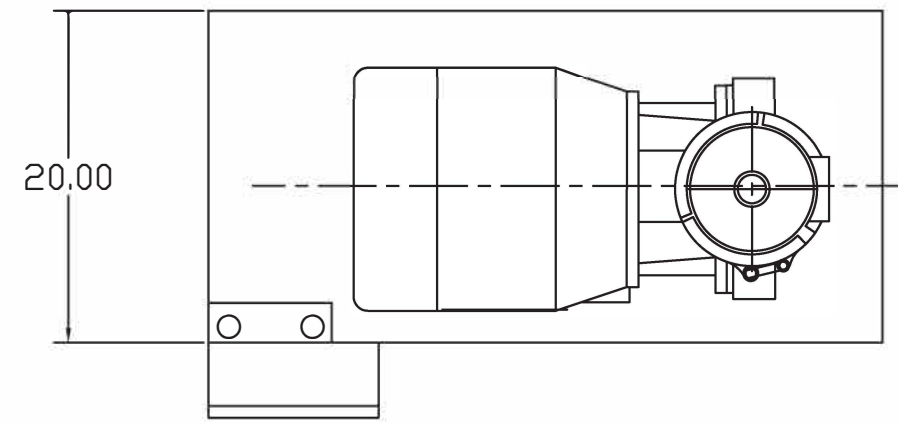
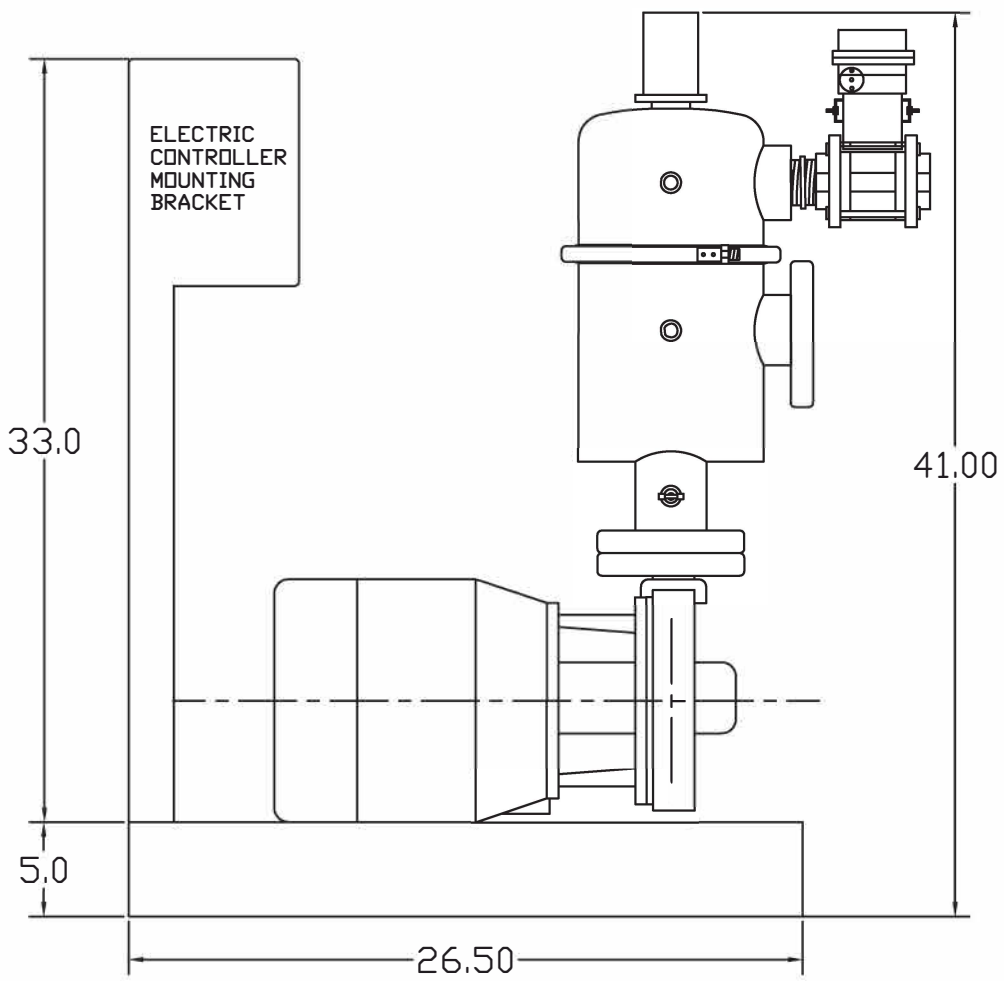

FLOWRATE: MAX. 200GPM
 DESIGN PRESS: 150PSI
 DESIGN TEMP: 160°F
 PUMP POWER: 5HP
 WEIGHT: 200LBS

UNLESS OTHERWISE SPECIFIED DIMENSIONS ARE IN INCHES TOLERANCES DECIMALS ANGULAR .XX ± .05 ± 0.5 DEG. .XXX ± .01				
DRAWN	DATE	TITLE		
JORDEN KAWAMOTO	05/13/13	MTF3 FILTER W/ EBV, GB6, AND ELECTRIC MOTOR MOUNTED ON SKID UNIT		
CHECKED		SIZE	DWG NO.	REV
		A	SKID-MTF3-CUT-01	N/A
DESIGN		SCALE 1:6		SHEET OF