

DESIGN NOTES:

1. VALVE - 89H22

1.1. MATERIAL:

- 1.1.1. VALVE BODY: CF8M STAINLESS STEEL
- 1.1.2. BALL: 316 STAINLESS STEEL
- 1.1.3. SEATS: VIRGIN PTFE
- 1.1.4. STEM: 316 STAINLESS STEEL
- 1.1.5. STEM PACKING: PTFE AND VITON

1.2. VALVE PERFORMANCE / SPECS:

- 1.2.1. 1.5" FULL PORT 2-WAY ON/OFF
- 1.2.2. 2 PORTS - 1.5" FNPT
- 1.3. MAX WORKING PRESSURE: 1000 PSI @ 70F
- 1.3.1. MAX DIFFERENTIAL PRESSURE: 200 PSI @ 70F
- 1.4. FLOW RATE: 170 GPM @ 1 PSI DROP (WATER)
- 1.5. VALVE REPAIR KIT: EH-128-1

2. ACTUATOR - 8-ACTR

2.1. MATERIAL:

- 2.1.1. CASE: GF NYLON
- 2.1.2. GASKET: SILICONE
- 2.1.3. DOME: LEXAN

2.2. ELECTRICAL:

- 2.2.1. VOLTAGE: 24 VAC
- 2.2.2. CABLE: 3 WIRE, 18 AWG, GXL CABLE
- 2.2.3. CURRENT:
 - OPERATING: 1.5A NOMINAL
 - STALL: 4A NOMINAL
- 2.2.4. CONNECTOR: DEUTSCH 4 PIN RECEPTACLE
 - PIN 1: BLACK - POWER IN (-)
 - PIN 2: - - -
 - PIN 3: WHITE - SIGNAL 1 (+) TO OPEN
 - PIN 4: RED - POWER IN (+)

2.3. OPERATION:

- 2.3.1. ON/OFF
- 2.3.2. CYCLE TIME: 1.5S @ 24 VAC

2.4. TEMPERATURE RATING:

- OPERATING: -32° F TO 125° F
- STORAGE: -40° F TO 185° F

2.5. ENCLOSURE RATING:

- NEMA 6P (IMMERSIBLE)
- NEMA 7D (IGNITION SAFE)

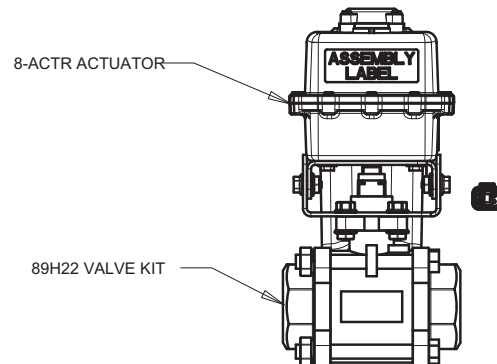
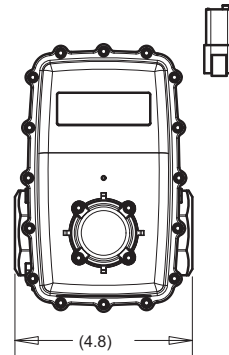

POSITION INDICATING FLAG

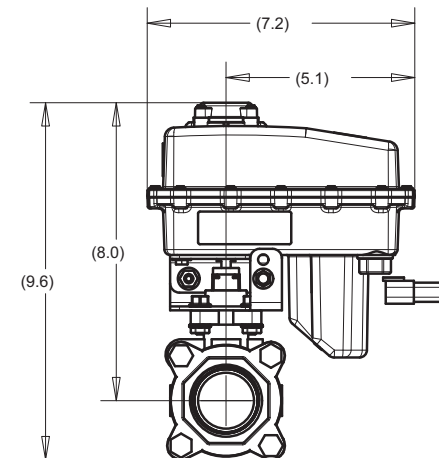
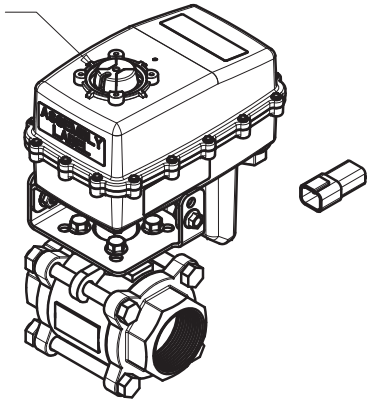

For more information:

WEB: FLTR.com.au PHONE: (+61) 1300 62 4020 EMAIL: info@FLTR.com.au SKYPE: Purple.Engineering