

## DESIGN NOTES:

1. VALVE - 89IC2
  - 1.1. MATERIAL:
    - 1.1.1. VALVE BODY: CF8M STAINLESS STEEL
    - 1.1.2. BALL: 316 STAINLESS STEEL
    - 1.1.3. SEATS: VIRGIN PTFE
    - 1.1.4. STEM: 316 STAINLESS STEEL
    - 1.1.5. STEM PACKING: PTFE AND VITON
  - 1.2. VALVE PERFORMANCE / SPECS:
    - 1.2.1. 2" FULL PORT 2-WAY ON/OFF
    - 1.2.2. 2 PORTS - 2" FNPT
  - 1.3. MAX WORKING PRESSURE: 1000 PSI @ 70F
    - 1.3.1. MAX DIFFERENTIAL PRESSURE: 200 PSI @ 70F
  - 1.4. FLOW RATE: 376 GPM @ 1 PSI DROP
  - 1.5. VALVE REPAIR KIT: EH-129C
2. ACTUATOR - 8-ACTR
  - 2.1. MATERIAL:
    - 2.1.1. CASE: GF NYLON
    - 2.1.2. GASKET: SILICONE
    - 2.1.3. DOME: LEXAN
  - 2.2. ELECTRICAL:
    - 2.2.1. VOLTAGE: 24 VAC
    - 2.2.2. CABLE: 3 WIRE, 18 AWG, GXL CABLE
    - 2.2.3. CURRENT:
      - OPERATING: 1.5A NOMINAL
      - STALL: 4A NOMINAL
    - 2.2.4. CONNECTOR: DEUTSCH 4 PIN RECEPTACLE
      - PIN 1: BLACK - POWER IN (-)
      - PIN 2: - - -
      - PIN 3: WHITE - SIGNAL 1 (+) TO OPEN
      - PIN 4: RED - POWER IN (+)
  - 2.3. OPERATION:
    - 2.3.1. ON/OFF
    - 2.3.2. CYCLE TIME: 1.5S @ 24 VAC
  - 2.4. TEMPERATURE RATING:
    - OPERATING: -32° F TO 125° F
    - STORAGE: -40° F TO 185° F
  - 2.5. ENCLOSURE RATING:
    - NEMA 6P (IMMERSIBLE)
    - NEMA 7D (IGNITION SAFE)

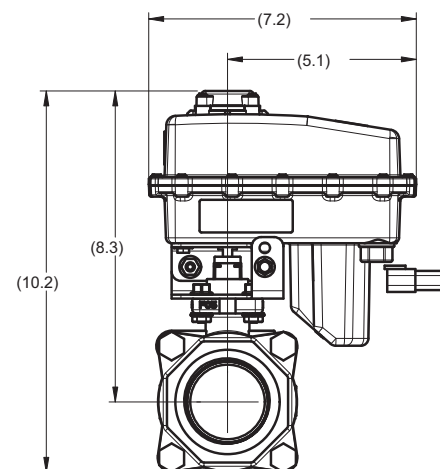
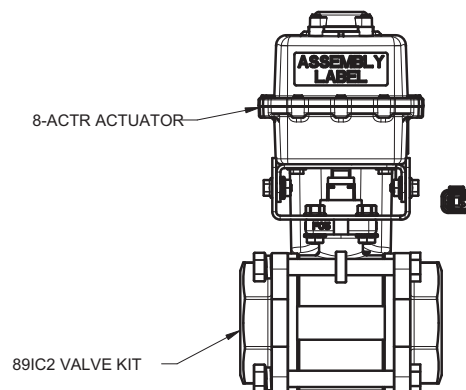
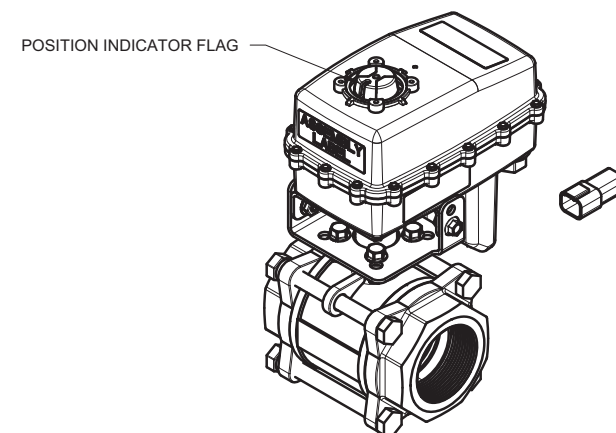
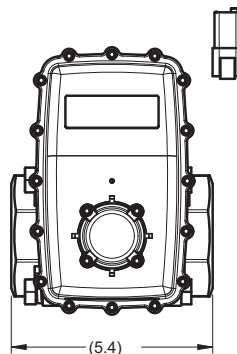

For more information:

WEB: [FLTR.com.au](http://FLTR.com.au) PHONE: (+61) 1300 62 4020 EMAIL: [info@FLTR.com.au](mailto:info@FLTR.com.au) SKYPE: Purple.Engineering