

## Engineering Specification

Job Name \_\_\_\_\_

Contractor \_\_\_\_\_

Job Location \_\_\_\_\_

Approval \_\_\_\_\_

Engineer \_\_\_\_\_

Contractor's P.O. No. \_\_\_\_\_

Approval \_\_\_\_\_

Representative \_\_\_\_\_

# LEAD FREE\*

## Series 77F-DI-125, 77F-DI-FDA-125

### Flanged, Wye Pattern, Cast Iron Strainers

Sizes: 2" – 12"

Series 77F-DI-125, 77F-DI-FDA-125 Flanged, Wye Pattern, Cast Iron Strainers feature 304 stainless steel perforated screens, a cast iron flanged retainer cap and a drain/blowoff connection furnished with a closure plug. Series 77F-DI-FDA-125 also features a double coated, heat fused epoxy coating on the interior and exterior for FDA approved sanitary applications.

#### Features

- Flanges conform to American National Standards Institute, Class 125 (ANSI B16.1) and WW-S-2739 Type 2
- Lead Free\* cast iron body
- 304 Stainless steel perforated screens
- Cast iron flanged retainer cap with gasket tapped for closure plug
- Drain/Blowoff connection furnished with closure plug
- Series 77F-DI-FDA-125 comes with heat fused FDA approved epoxy coating (interior and exterior)

#### Models

77F-DI-125 — 2" – 12" with flanged connections for water and steam service

77F-DI-FDA-125 — 2" – 12" with flanged connections and double coated, heat fused FDA approved epoxy coating (interior and exterior) for water service only

#### Specifications (77F-DI-125)

A flanged, wye pattern, cast iron strainer to be installed as indicated on the plans. The strainer must have flanges that conform to American National Standards Institute, Class 125, 304 stainless steel perforated screens and a drain/blowoff connection furnished with a closure plug. Pressure rating no less than 200psi (13.8 bar) WOG non-shock and 125psi (8.6 bar) WSP. Strainer shall be a Watts Series 77F-DI-125.

\*The wetted surface of this product contacted by consumable water contains less than 0.25% of lead by weight.



77F-DI-FDA-125

#### Pressure – Temperature

Maximum Operating Pressure:  
200psi (13.8 bar) WOG, non-shock, @ 210°F (99°C)  
125psi (8.6 bar) WSP @ 353°F (178°C)

#### Standard Screens

2" – 5": 1/16" perforation  
6" – 8": 1/8" perforation  
10" – 12": 3/16" perforation

#### Screen Options

Wire Mesh Liners: 304 stainless steel (#20, #40, #60, #80, #100)  
Perforated Screens: 304 stainless steel (3/64", 1/16", 1/8", 3/16")

#### Specifications (77F-DI-FDA-125)

A flanged, wye pattern, cast iron strainer with a double coated, heat fused, FDA approved epoxy coating on the interior and exterior surfaces for FDA sanitary applications. Flanges to conform to ANSI B16.1 Class 125, 304 stainless steel perforated screens, and a drain/blowoff connection furnished with a closure plug. Pressure rating 200psi (13.8 bar) WOG. Strainer shall be a Watts Series 77F-DI-FDA-125.

#### NOTICE

The information contained herein is not intended to replace the full product installation and safety information available or the experience of a trained product installer. You are required to thoroughly read all installation instructions and product safety information before beginning the installation of this product.



Watts product specifications in U.S. customary units and metric are approximate and are provided for reference only. For precise measurements, please contact Watts Technical Service. Watts reserves the right to change or modify product design, construction, specifications, or materials without prior notice and without incurring any obligation to make such changes and modifications on Watts products previously or subsequently sold.



## Materials

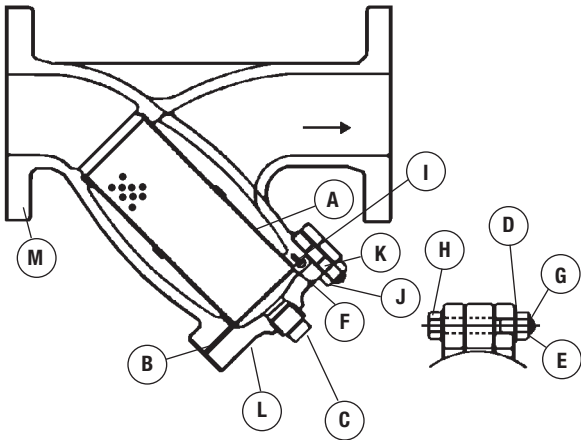

A.	Screen	AISI 304SS
B.	Cover Gasket	Graphite
C.	Plug	*ASTM A47
D.	Washer	ASTM A6
E.	Cotter Pin	ASTM A112
F.	Plate	*ASTM A6
G.	Bolt Nut	ASTM A6
H.	Bolt	ASTM A6
I.	Set Screw	ASTM B16
J.	Cover Bolt Nut	ASTM A6
K.	Cover Bolt	ASTM A6
L.	Cover	*ASTM A-126 Class B
M.	Body	*ASTM A-126 Class B

**Note:**\* 77F-DI-FDA-125 component parts epoxy coated internally and externally.

## Standards

Tested and Certified by NSF International



## Dimensions – Weights

SIZE		DIMENSIONS								WEIGHT		
<i>in.</i>	<i>mm</i>	A	B	C(NPT)	D*	Screen Area	lbs.	kgs.				
<i>in.</i>	<i>mm</i>	<i>in.</i>	<i>mm</i>	<i>in.</i>	<i>mm</i>	<i>sq.in.</i>	<i>lbs.</i>	<i>kgs.</i>				
2	77/8	200	51/4	133	1/2	36	18	8				
2 1/2	10	254	6 1/2	165	1	56	28	13				
3	10 1/8	257	7	178	1	75	34	15				
4	12 1/8	308	8 1/4	210	1 1/2	121	60	27				
5	15 3/8	397	11 1/4	286	2	210	95	43				
6	18 1/2	470	13 1/2	343	2	278	133	60				
8	21 3/8	551	15 1/2	394	2	387	247	112				
10	26	660	18 1/2	470	2	577	370	168				
12	29 3/8	759	21 3/4	552	2	795	579	262				

\* D dimension is minimum clearance for screen removal.



## Flow/Pressure Drop Chart

