

## Engineering Specification

Job Name \_\_\_\_\_

Contractor \_\_\_\_\_

Job Location \_\_\_\_\_

Approval \_\_\_\_\_

Engineer \_\_\_\_\_

Contractor's P.O. No. \_\_\_\_\_

Approval \_\_\_\_\_

Representative \_\_\_\_\_

# LEAD FREE\*

## Series LF777, LFS777 Wye-Pattern Lead Free\* Bronze Strainers

Sizes: 1/4" – 4"

Series LF777, LFS777 Wye-Pattern Lead Free\* cast copper silicon alloy Strainers are designed to protect system components from dirt, rust and other damaging debris in the piping system. This series features a solid retainer cap with gasket. The LF777 and LFS777 features Lead Free\* construction to comply with Lead Free\* installation requirements.

### Features

- Lead Free\* cast copper silicon alloy body
- Wye-pattern
- Solid retainer cap with gasket

### Models

LF777 1/4" – 4" threaded connections  
LFS777 1/2" – 2" solder connections

### Specifications

A wye-pattern Lead Free\* cast copper silicon alloy strainer to be installed as indicated on the plans. The strainer must have a solid retainer cap with gasket. Strainer shall be rated to 400psi (27.6 bar) WOG @ 210°F (99°C); 125psi (8.6 bar) WSP @ 353°F (178°C) for sizes 1/4" – 3" and 300psi (20.7 bar) WOG @ 210°F (99°C); 125psi (8.6 bar) @ 353°F (178°C) for size 4". Lead Free\* Wye-Pattern cast copper silicon alloy Strainers shall be constructed using Lead Free\* materials. Lead Free strainers shall comply with state codes and standards, where applicable, requiring reduced lead content. Strainer shall be a Watts Series LF777 (threaded ends) or LFS777 (solder ends).

### Materials

Body: Lead Free\* cast copper silicon alloy  
Retainer Cap: 1/4" – 4": Lead Free copper silicon alloy  
Cap Seal: 1/4" – 3": EPDM O-Ring  
4": Garlock® gasket  
Standard Screen: 1/2" – 2 1/2": 304 stainless steel #20 mesh,  
3": 3/64" (1.2mm) 304 stainless steel perforated screen  
4": 1/8" (3mm) 304 stainless steel perforated screen



LF777



LFS777

### Approvals



### Pressure – Temperature

Maximum Working Pressure:

1/4" – 3"  
400psi (27.6 bar) WOG @ 210°F (99°C)  
125psi (8.6 bar) WSP @ 353°F (178°C)  
4"  
300psi (20.7 bar) WOG @ 210°F (99°C)  
125psi (8.6 bar) WSP @ 353°F (178°C)

### NOTICE

The information contained herein is not intended to replace the full product installation and safety information available or the experience of a trained product installer. You are required to thoroughly read all installation instructions and product safety information before beginning the installation of this product.

### NOTICE

Inquire with governing authorities for local installation requirements

\*The wetted surface of this product contacted by consumable water contains less than 0.25% of lead by weight.

Watts product specifications in U.S. customary units and metric are approximate and are provided for reference only. For precise measurements, please contact Watts Technical Service. Watts reserves the right to change or modify product design, construction, specifications, or materials without prior notice and without incurring any obligation to make such changes and modifications on Watts products previously or subsequently sold.

# WATTS®

**FLTR**  
Purple Engineering

## Screen Options

304 Stainless Steel Wire Mesh Liners:  
 (#30, #40, #60, #80, #100)

304 Stainless Steel Perforated Screens:  
 (1/32", 3/64", 1/16", 1/8", 3/16", 1/4")

Consult factory for ordering codes

## Performance Data

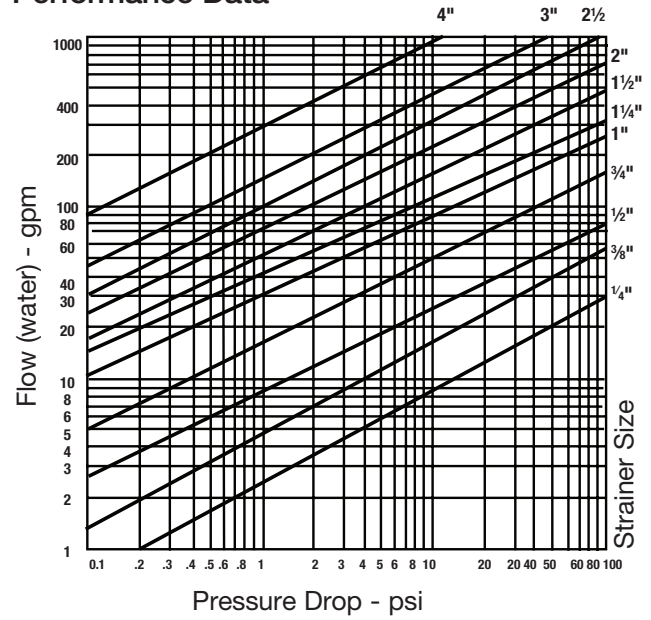

## Dimensions – Weights

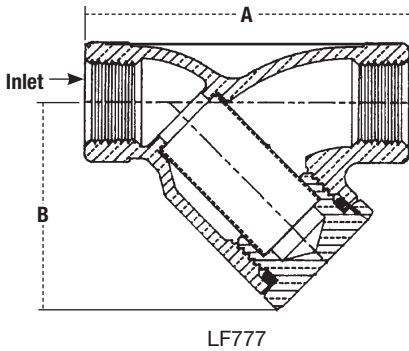

### LF777

SIZE	DIMENSIONS				WEIGHT	
	A		B		lbs.	kgs
1/4	in.	mm	in.	mm		
1/4	2 11/16	68	1 11/16	43	1.7	0.77
3/8	2 11/16	68	1 11/16	43	1.7	0.77
1/2	3	76	2	51	1.7	0.77
3/4	3 5/16	84	2 5/16	59	1.7	0.77
1	4 1/2	114	2 5/16	59	2.7	1.22
1 1/4	5 5/8	130	3 3/8	79	3.0	1.36
1 1/2	5 7/8	149	3 3/4	95	4.0	1.81
2	6 3/16	157	4 7/8	124	7.4	3.36
2 1/2	8 1/8	206	4 15/16	125	12.0	5.44
3	10 1/8	257	6 11/16	170	24.0	10.90
4	13	325	10 1/2	267	41.0	18.60

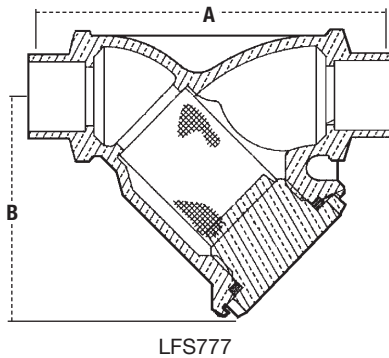

### LFS777

SIZE	DIMENSIONS				WEIGHT	
	A		B		lbs.	kgs
1/2	in.	mm	in.	mm		
1/2	3 3/8	86	2 1/16	52	1.5	0.68
3/4	3 3/4	95	2 7/16	63	1.6	0.73
1	5	127	3	76	2.5	1.13
1 1/4	5 5/8	143	3 1/4	82	2.8	1.25
1 1/2	6 7/16	164	3 13/16	97	4.0	1.81
2	7 1/2	191	4 5/8	118	7.4	3.39

