

Engineering Specification

Job Name _____

Contractor _____

Job Location _____

Approval _____

Engineer _____

Contractor's P.O. No. _____

Approval _____

Representative _____

Ductile Iron Screwed End Y Strainer

Model: 251-DI, Class 300

Sizes: 1/4" - 3" (8 - 80mm)

Typical Service

- Used extensively to strain foreign matter from pipelines and provide economical protection for costly pumps, meters, valves, and other similar mechanical equipment.

Features

- Machined seats in both body and cap align and lock the screen in place to stop sediment bypass.

Construction

- Gasketed cap is used for easy disassembly and assembly. Many others use Loctite, rendering disassembly virtually impossible.

NOTE: Bolted covers are supplied on sizes 2½" and 3".

Self-Cleaning

- Self-cleaning is accomplished by opening the plug or valve connected to the blowoff outlet.

Blowoff Outlets

- Outlets are NPT tapped.
- Sizes of tapping are specified on next page.
- Not normally furnished with plug. Plug available, specify with order.

Capacity

- Generously proportioned bodies.
- Open Area Ratio much greater than pipe size, ensuring low pressure drop.



Model 251-DI

PRESSURE/TEMPERATURE - NON-SHOCK

Model	Material	Rating
251-D1	Ductile iron	640psi @ 100°F 450psi @ 650°F

Screens

Model	Sizes	Material	Opening	STANDARD (WATER)		STEAM RECOMMENDATION	
				Material	Opening	Material	Opening
251-DI	¼" - 3"	304SS	.062 perf	304SS	.045 perf		

NOTICE

The information contained herein is not intended to replace the full product installation and safety information available or the experience of a trained product installer. You are required to thoroughly read all installation instructions and product safety information before beginning the installation of this product.

Mueller Steam Specialty product specifications in U.S. customary units and metric are approximate and are provided for reference only. For precise measurements, please contact Mueller Steam Specialty Technical Service. Mueller Steam Specialty reserves the right to change or modify product design, construction, specifications, or materials without prior notice and without incurring any obligation to make such changes and modifications on Mueller Steam Specialty products previously or subsequently sold.



A WATTS Brand

BILL OF MATERIAL

Item	QTY		Description
1	1	Body	Ductile Iron SA536 65-45-12
2	1	Cap	Duplicate Ion SA536 65-45-12
3	1	Screen	304 ST. STL.
4	1	Gasket	316 ST. STL. Tanged Graphoil

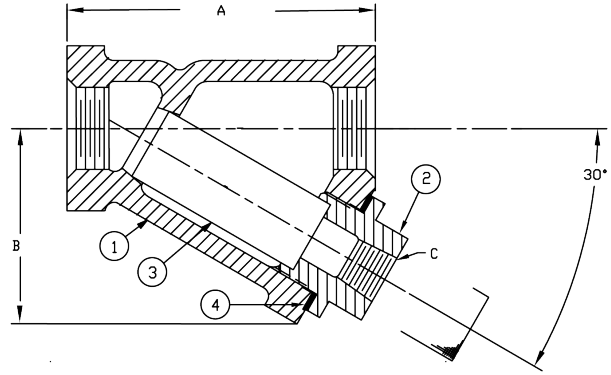

MODEL 251-DI

Dimensions and Weights

SIZE		DIMENSIONS						WEIGHT	
		A		B		C (NPT)			
in.	mm	in.	mm	in.	mm	in.	mm	lbs.	kgs.
1/4	6	3 ¹³ / ₁₆	97	2 ³ / ₁₆	56	3/8	10	2	.9
3/8	10	3 ¹³ / ₁₆	97	3 ³ / ₁₆	56	3/8	10	2	.9
1/2	15	3 ¹³ / ₁₆	97	2 ³ / ₁₆	56	3/8	10	2	.9
3/4	20	4 ³ / ₄	120	2 ⁷ / ₈	73	1/2	12	2.5	1.1
1	25	5 ⁷ / ₁₆	138	3 ¹ / ₄	83	3/4	15	4	1.8
1 1/4	32	6 ⁵ / ₁₆	160	3 ³ / ₄	95	3/4	15	5	2.2
1 1/2	40	7 ¹ / ₂	190	4 ¹¹ / ₁₆	119	1	25	7.5	3.4
2	50	8 ¹ / ₈	206	5 ¹ / ₂	140	1 1/4	32	12	5.4
2 1/2	65	10 ¹ / ₂	266	6 ⁵ / ₈	168	1 1/2	40	22	10
3	80	12 ¹ / ₂	318	6 ⁷ / ₈	175	1 1/2	40	33	15

Apply for certified drawings.

Pressure Drop

- See Pressure Drop Charts in Technical Data Section in the Mueller Steam Specialty Engineering binder.

Limited Warranty: Mueller Steam Specialty warrants each product to be free from defects in material and workmanship under normal usage for a period of one year from the date of original shipment. In the event of such defects within the warranty period, the Company will, at its option, replace or recondition the product without charge. This shall constitute the sole and exclusive remedy for breach of warranty, and the Company shall not be responsible for any incidental, special or consequential damages, including without limitation, lost profits or the cost of repairing or replacing other property which is damaged if this product does not work properly, other costs resulting from labor charges, delays, vandalism, negligence, fouling caused by foreign material, damage from adverse water conditions, chemical, or any other circumstances over which the Company has no control. This warranty shall be invalidated by any abuse, misuse, misapplication or improper installation of the product. **THIS WARRANTY IS IN LIEU OF ALL OTHER WARRANTIES, EXPRESS OR IMPLIED, INCLUDING ANY IMPLIED WARRANTIES OF MERCHANTABILITY OR FITNESS FOR A PARTICULAR PURPOSE.** Any implied warranties that are imposed by law are limited in duration to one year.

Some States do not allow limitations on how long an implied warranty lasts, and some States do not allow the exclusion or limitation of incidental or consequential damages. Therefore the above limitations may not apply to you. This Limited Warranty gives you specific legal rights, and you may have other rights that vary from State to State. You should consult applicable state laws to determine your rights.



A WATTS Brand

