

Engineering Specification

Job Name _____
 Job Location _____
 Engineer _____
 Approval _____

Contractor _____
 Approval _____
 Contractor's P.O. No. _____
 Representative _____

LEAD FREE*

Cast Iron Flanged End Wye Strainers

Model: 752, Class 250
752 SM, Class 250

Sizes: 1½" – 24", 2" – 24" (752 SM Only)

The 752 and 752 SM wye strainers provide economical protection for costly pumps, meters, valve and other similar mechanical equipment by straining foreign matter from the piping system. Installation of a strainer before mechanical equipment can ensure trouble free service and avoid costly shutdowns for repair or replacement of equipment damaged by foreign matter.

Smart and Connected technology comes standard on the NEW 752 SM wye strainer with two pre-installed pressure sensors at the inlet and outlet of the strainer. These sensors monitor the pressure drop that occurs over time when a strainer screen becomes clogged by foreign particles. When the differential pressure across the strainer screen exceeds the preconfigured threshold, an alert is triggered to the customer informing that action is required. The Sensor Monitoring Control Unit & Connection kit is required to activate the pressure monitoring capability and collect data. Without the connection kit, the sensors are passive components that do not communicate with any other device. The add-on connection kit communicates over communicates over wired RS-485 MODBUS or BACnet connection and is compatible with most Building Management and Building Automation Systems. An alternate cellular communication gateway option is available if no BMS is present, however this option provides alerts only, data streaming is not available.

Features

- Mueller "Breach-Lok Strainers"
- Furnished as standard in sizes 8" and larger
- A one-quarter turn securely locks the screen in its seat
- Allows for easy bolting of the cover flange
- Tapered seats in both the body and cover flange retain screen and prevent particle bypass

Available Features with Sensor Control Monitor Installed

- Real-time pressure monitoring
- Visual Display - Pressure data for each sensor, Screen Pressure differential, Screen fill percentage
- Data streaming if connected to BMS [RS-485 MODBUS or BacNet]
- Full screen alerts
- Optional Cellular Communications Gateway

*The wetted surface of this product contacted by consumable water contains less than 0.25% of lead by weight.

Mueller Steam Specialty product specifications in U.S. customary units and metric are approximate and are provided for reference only. For precise measurements, please contact Mueller Steam Specialty Technical Service. Mueller Steam Specialty reserves the right to change or modify product design, construction, specifications, or materials without prior notice and without incurring any obligation to make such changes and modifications on Mueller Steam Specialty products previously or subsequently sold.

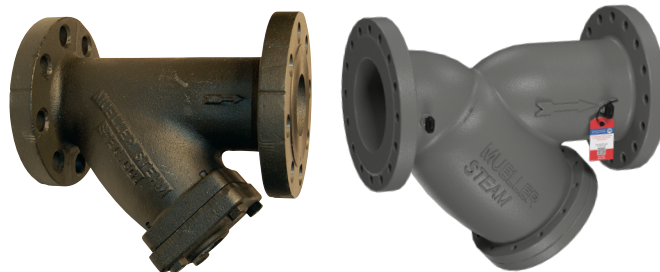

Model 752

Model 752 SM

Alerts

- Display
- Cellular Gateway
- LED
- RS-485 MODBUS and BacNet
- BMS Alarm

Call customer service if you need assistance with technical details.

PRESSURE/TEMPERATURE–NON-SHOCK			
752			
1½" - 12"		14" - 24"	
500 psi @ -20°F to 150°F		300 psi @ -20°F to 150°F	
35 bar @ -29°C to 66°C		21 bar @ -29°C to 66°C	
250 psi @ 450°F		200 psi @ 406°F	
17 bar @ 232°C		14 bar @ 208°C	
752 SM			
2" - 12"		14" - 24"	
500 psi @ -20°F to 150°F		300 psi @ -20°F to 150°F	
35 bar @ -29°C to 66°C		21 bar @ -29°C to 66°C	
410 psi @ 275°F		257 psi @ 257°F	
28 bar @ 125°C		18 bar @ 125°C	

Screens

STANDARD (WATER) STEAM RECOMMENDATION					
MODEL	SIZES	MATERIAL	OPENING	MATERIAL	OPENING
752 & 752 SM	1½" – 4"	304SS	.062 perf	304SS	.045 perf
	5" – 10"	304SS	.125 perf	304SS	.045 perf
	10" and Up	304SS	.125 perf	304SS	.062 perf

NOTICE

The information contained herein is not intended to replace the full product installation and safety information available or the experience of a trained product installer. You are required to thoroughly read all installation instructions and product safety information before beginning the installation of this product.



Construction

- Gasketed cover, O-ring seats available

Self-Cleaning

- Self-cleaning is accomplished by opening the plug or valve connected to the blowoff outlet

Blowoff Outlets

- Outlets are NPT tapped
- Sizes of tapping specified in dimensions table
- Not normally furnished with plug. Plug available, specify with order

Capacity

- Generously proportioned bodies
- Open Area Ratio much greater than pipe size, ensuring low pressure drop

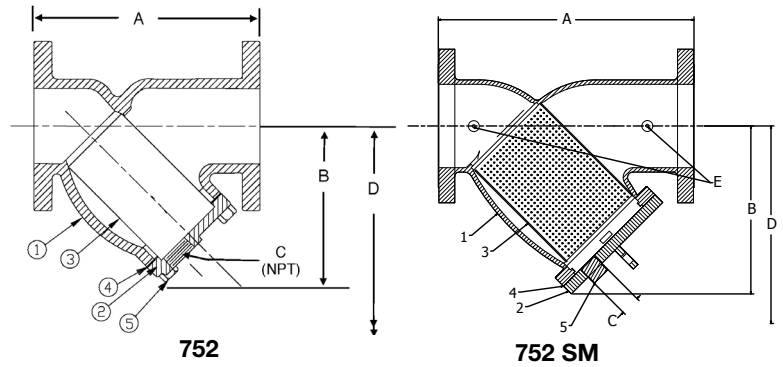

Materials

BILL OF MATERIAL - 752		
ITEM	DESCRIPTION	MATERIAL
1	Body	Cast Iron ASTM A126-B
2	Cover **	Cast Iron ASTM A126-B
3	Screen	304 SS
4	Gasket	Non-Asbestos
5	Hex Head Cap Screws	SAE J429 Gr. 5
6	Pressure Sensor	Mixed composite

** Cover may be manufactured from equivalent grade plate material

Dimensions and Weights

SIZE		DIMENSIONS						WEIGHT			
		A		B		C		E Sensor Port			
<i>in.</i>	<i>in.</i>	<i>mm</i>	<i>in.</i>	<i>mm</i>	<i>in.</i>	<i>mm</i>	<i>in.</i>	<i>mm</i>	<i>lbs.</i>	<i>kgs.</i>	
1½	8⅛	204	4¾	121	½	15	⅜	3	24	10.9	
2	9⅞	237	6	152	½	15	⅜	3	26	12	
2½	11⅞	281	7⅞	181	1	25	⅜	3	40	18	
3	12⅝	321	9⅞	232	1¼	32	⅜	3	59	26.8	
3½	14⅝	365	9	229	1¼	32	⅜	3	76	34	
4	15⅝	397	10⅞	276	1½	40	⅜	3	93	42	
5	18¼	464	12⅝	329	2	50	⅜	3	146	66	
6	20⅞	512	14½	368	2	50	⅜	3	194	88	
8	25⅞	638	16⅞	418	2	50	⅜	3	316	143	
10	29⅞	739	21	533	2	50	⅜	3	475	215	
12	33¾	857	25	635	2	50	⅜	3	750	3740	
14	38¾	984	28¾	730	2	50	⅜	3	908	412	
16	44⅞	1128	29⅞	752	2	50	⅜	3	1135	515	
18	47¾	1213	34⅞	881	2	50	⅜	3	2400	1090	
20	56	1422	39	991	2	50	⅜	3	3350	1522	
24	57½	1461	45	1143	2	50	⅜	3	4705	2138	

Apply for Certified Drawings.



A WATTS Brand

