

Engineering Specification

Job Name _____

Contractor _____

Job Location _____

Approval _____

Engineer _____

Contractor's P.O. No. _____

Approval _____

Representative _____

LEAD FREE*

Cast LOCXEND™

Y Strainers

758G

758G SM

2" – 12" (50 – 300 mm)

The 758G and 758G SM LOCXEND™ wye strainers provide economical protection for costly pumps, meters, valves, and similar mechanical equipment by straining foreign matter from the piping system. The LOCXEND™ wye strainers are designed for installation in grooved end piping systems.

Smart and Connected technology comes standard on the 758G SM wye strainer with two pre-installed pressure sensors at the inlet and outlet of the strainer. These sensors monitor the pressure drop that occurs over time when a strainer screen becomes clogged by foreign particles. When the differential pressure across the strainer screen exceeds the pre-configured threshold, an alert is triggered to the customer informing that action is required. The Sensor Monitoring Control Unit & Connection kit is required to activate the pressure monitoring capability and collect data. Without the connection kit, the sensors are passive components that do not communicate with any other device. The add-on connection kit communicates over wired RS-485 MODBUS or BACnet connection, and is compatible with most Building Management and Building Automation Systems. An alternate cellular communication gateway option is available if no BMS is present; however, this option provides alerts only. Data streaming is not available.

Features

- Mueller "BREECH-LOK STRAINERS"
 - Comes standard in 8" and larger
 - Securely locks the screen in its seat with one-quarter turn
 - Allows for easy bolting of the cover flange
- Tapered seats in both the body and cover flange to retain the screen and prevent particle bypass

*The wetted surface of this product contacted by consumable water contains less than 0.25% of lead by weight.



Model 758G



Model 758G SM

Call customer service if you need assistance with technical details.

PRESSURE/TEMPERATURE–NON-SHOCK		
MODEL	MATERIAL	CWP
758G	Ductile Iron	640 psi @ 100°F 44 bar @ 38°C 150 psi @ 565°F 10 bar @ 296°C
758G SM	Ductile Iron	500 psi @ 100° F 35 bar @ 38° C 500 psi @ 257° F 35 bar @ 125° C

Note: Pressure/Temperature can be limited by gasket material. Consult factory.

Available Features with Sensor Control Monitor Installed

- Real-time pressure monitoring
- Visual Display – Pressure data for each sensor, Screen Pressure differential, Screen fill percentage
- Data streaming if connected to BMS [RS-485 MODBUS or BACnet]
- Optional Cellular Gateway
- Full screen alerts

Alerts

- Display
- LED
- BMS Alarm
- Cellular Gateway
- RS-485 MODBUS and BACnet



NOTICE

The information contained herein is not intended to replace the full product installation and safety information available or the experience of a trained product installer. You are required to thoroughly read all installation instructions and product safety information before beginning the installation of this product.

Mueller Steam Specialty product specifications in U.S. customary units and metric are approximate and are provided for reference only. For precise measurements, please contact Mueller Steam Specialty Technical Service. Mueller Steam Specialty reserves the right to change or modify product design, construction, specifications, or materials without prior notice and without incurring any obligation to make such changes and modifications on Mueller Steam Specialty products previously or subsequently sold.

Mueller Steam Specialty™

FLTR
Purple Engineering

Construction

- All covers have NPT blow-off outlet at Location C.
- Recessed seat in the cover assures accurate screen alignment.
- Bosses at the inlet and outlet flanges are provided for the gauge taps.

Self-cleaning

- Accomplished by opening the plug or valve connected to the blow-off outlet.
- Advised when strainers are to be mounted in vertical piping so the cover can be rotated to position the blow-off at the lowest point.

Blow-off Outlets

- Outlets are NPT tapped.
- Sizes of tapping specified in dimensions table.
- Not normally furnished with plug. Plug available; specify with order.

Capacity

- Generously proportioned bodies.
- Open Area Ratio much greater than pipe size, ensuring low pressure drop.

Screens

MODEL	SIZE	STANDARD (WATER)		STEAM RECOMMENDATION	
		MATERIAL	OPENING	MATERIAL	OPENING
758	IN.				
758G & 758G SM	2 – 4	304SS	0.062 perf	304SS	0.045 perf
758G & 758G SM	5 – 8	304SS	0.125 perf	304SS	0.045 perf
758G & 758G SM	10 and up	304SS	0.125 perf	304SS	0.062 perf

Dimensions and Weights

SIZE	DIMENSIONS								PRESSURE SENSOR PORT		WEIGHT		Cv VALUE
	A		B		C (NPT)		D SCREEN REMOVAL		E (NPT)		lb	kg	GPM
in.	in.	mm	in.	mm	in.	mm	in.	mm	in.	mm			
2	7 7/8	200	5 1/4	133	1/2	13	7	178	1/8	3	12	5.44	70
2 1/2	10	254	6 1/2	165	1	25	9 3/4	248	1/8	3	18	8.16	110
3	10 1/8	257	7	178	1	25	10	254	1/8	3	23	10.40	140
4	12 1/8	308	8 1/4	210	1 1/2	38	12	305	1/8	3	42	19	245
5	15 5/8	397	11 1/4	286	2	51	17	432	1/8	3	80	36.30	400
6	18 1/2	470	13 1/2	343	2	51	20	508	1/8	3	112	50.80	600
8	21 5/8	549	15 1/2	394	2	51	22 3/4	578	1/8	3	205	93	1000
10	29 1/8	654	19 1/4	470	2	51	28	711	1/8	3	277	125.60	1580
12	33 3/4	762	22 7/8	552	2	51	30	762	1/8	3	470	213.20	2200

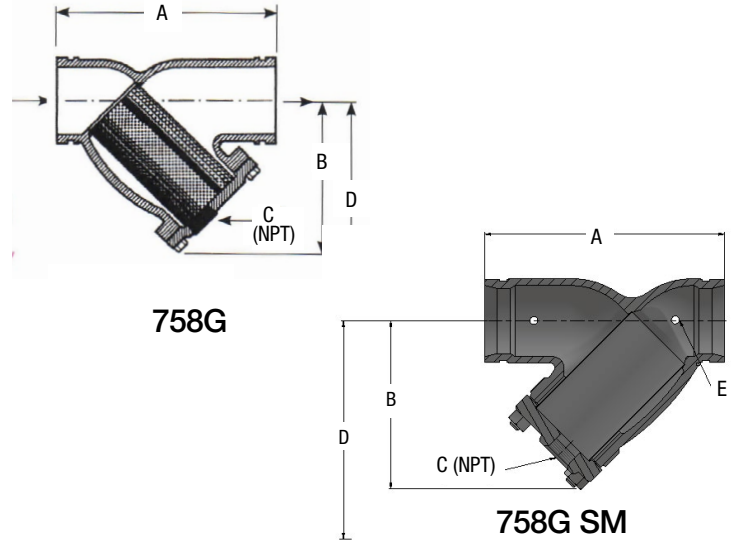

Materials

BILL OF MATERIAL	
DESCRIPTION	MATERIAL
Body	Ductile Iron SA 536 65-45-12
Cover**	Ductile Iron SA 536 65-45-12
Screen	304 SS
Gasket	Non-Asbestos
Hex Head Cap Screw	SAE J429 Gr. 5
Pressure Sensor	Mixed Composite

**Cover may be manufactured from equivalent grade plate material



A WATTS Brand

