

Engineering Specification

Job Name _____
 Job Location _____
 Engineer _____
 Approval _____

Contractor _____
 Approval _____
 Contractor's P.O. No. _____
 Representative _____

Cast Stainless Steel Flanged End Y Strainers

Models: 764-SS, Class 600
 765M-SS*, Class 900
 766M-SS, Class 1500
 767-SS, Class 2500

Sizes: 1/2"- 12" (15 – 300mm)

* 765M and 766M supersede models
 765/766. Consult factory.

Typical Service

- Used extensively to strain foreign matter from pipelines and provide economical protection for costly pumps, meters, valves, and other similar mechanical equipment.
- Well suited for long service in high pressure and temperature applications.

Features

- Machined seats in both body and cap align and lock the screen in place to stop sediment bypass.
- Machined seats facilitate alignment and accurate reseating after servicing.

Construction

- Designed for high pressure and temperature services.
- Heavy gauge reinforced screens are used.
- Flanged are back faced, or spot faced at the boltholes.
- Ring Type Joint (RTJ) flanges are available, consult factory.

Self-Cleaning

- Self-cleaning is accomplished by opening the plug or valve connected to the blowoff outlet, if provided.
- Cleaning usually accomplished by shutting off line pressure and disassembling strainer.

Blowoff Outlets

- Cover flange for 764-SS is furnished with blowoff tapping, not plugged.
- All other covers normally furnished as blind flanges. Socket weld blowoff connection available, specify on order.

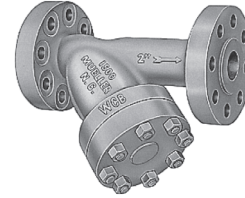

Models 764-SS, 765M-SS, 766M-SS, 767-SS

Pressure/Temperature–Non-Shock

Model	Material	Rating
764-SS	Stainless Steel	1440psi @ -20°F to 100°F 99.3 bar @ 38°C 725psi @ 1000°F 50 bar @ 538°C
765M-SS	Stainless Steel	2160psi @ -20°F to 100°F 148.9 bar @ 38°C 1090psi @ 1000°F 75.2 bar @ 538°C
766M-SS	Stainless Steel	3600psi @ -20°F to 100°F 248.2 bar @ 38°C 1820psi @ 1000°F 125.5 bar @ 538°C
767-SS	Stainless Steel	6000psi @ -20 to 100°F 413.7 bar @ 38°C 3030psi @ 1000°F 208.9 bar @ 538°C

Capacity

- Generously proportioned bodies.
- Open Area Ratio much greater than pipe size, ensuring low pressure drop.
- Minimum of 4 to 1 Open Area Ratio using standard 1/16 and 1/8 perf screens.

Screens

MODEL	SIZES	STANDARD (WATER)		STEAM RECOMENDATION	
		MATERIAL	OPENING	MATERIAL	OPENING
All	1/2" - 4"	304SS	.062 perf	304SS	.033 perf
All	5" and Up	304SS	.125 perf	304SS	.045 perf

NOTICE

The information contained herein is not intended to replace the full product installation and safety information available or the experience of a trained product installer. You are required to thoroughly read all installation instructions and product safety information before beginning the installation of this product.

Mueller Steam Specialty product specifications in U.S. customary units and metric are approximate and are provided for reference only. For precise measurements, please contact Mueller Steam Specialty Technical Service. Mueller Steam Specialty reserves the right to change or modify product design, construction, specifications, or materials without prior notice and without incurring any obligation to make such changes and modifications on Mueller Steam Specialty products previously or subsequently sold.

Mueller Steam Specialty™

FLTR
Purple Engineering

Material

764-SS, 765M-SS, 766M-SS, 767-SS	
Body	Stainless Steel, ASTM A351 Grade CF8M
Cover	Stainless Steel, ASTM A351 Grade CF8M
Gasket	Spiral Wound SS, Graphite Filled

* Cover may also be manufactured from equivalent grade plate material.

Pressure Drop

- See Pressure Drop Charts in Technical Data Section of the Mueller Steam Specialty Engineering binder.

Dimensions and Weights

SIZE		DIMENSIONS				WEIGHT					
		A		B		C		D Screen Removal			
in.	mm	in.	mm	in.	mm	in.	mm	in.	mm	lbs.	kgs.
764											
1/2	15	6 5/8	168	3 1/2	89	3/8	10	5	130	6	2.7
3/4	20	8 9/16	211	3 3/4	95	1/2	15	5	130	12.3	5.5
1	25	8 9/16	211	3 3/4	95	1/2	15	5	130	12.3	5.5
1 1/4	32	10 1/8	257	5 1/2	140	1/2	15	8	203	19	8.6
1 1/2	40	10 1/4	260	5 1/2	140	1/2	15	8	203	27	12
2	50	11	279	7	178	1/2	15	10	254	40	18
2 1/2	65	12	305	8 1/4	210	1	25	12 1/2	318	60	27
3	80	13 1/2	343	9 1/4	235	1 1/4	32	14 1/2	368	78	35
4	100	17 15/16	456	12 1/2	318	1 1/2	40	19 1/2	495	160	72.7
5	125	22 1/4	565	15	381	2	50	23	584	254	115
6	150	25 5/8	651	20	508	2	50	31	787	364	165
8	200	31 3/4	806	24	610	2	50	38 1/2	978	670	304
10	250	37 11/16	957	28 1/2	724	2	50	45 1/2	1156	1090	495
12	300	45 1/2	1156	34 1/2	876	2	50	52	1321	1558	708

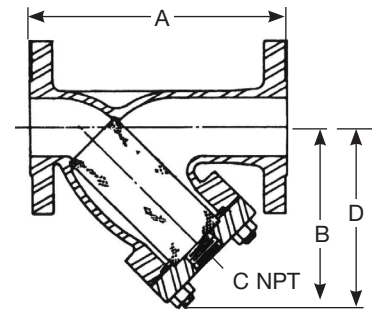

Model 764-SS

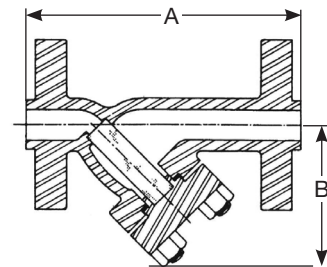

Models 765M-SS, 766M-SS, 767-SS

SIZE		DIMENSIONS				WEIGHT	
		A		B			
in.	mm	in.	mm	in.	mm	lbs.	kgs
765M							
1/2	15	8 1/8	206	4 1/4	108	20	9
3/4	20	9 1/16	230	4 3/4	121	30	13.6
1	25	10 11/16	271	5 3/4	146	52	23
1 1/4	32	12	305	6 3/4	171	64.5	29
1 1/2	40	12	305	6 3/4	171	64.5	29
2	50	13 15/16	354	7 1/2	191	93	42
2 1/2	65	17 1/2	445	10 3/4	273	185	84
3	80	17 1/2	445	10 3/4	273	185	84
4	100	23 3/4	591	15	381	250	113
5	125	—	—	—	—	—	—
6	150	27 3/4	705	18 7/8	479	560	254
8	200	33 3/4	846	23 7/8	606	1000	454
10	250	CF	CF	CF	CF	CF	CF
12	300	CF	CF	CF	CF	CF	CF

SIZE		DIMENSIONS				WEIGHT	
		A		B			
in.	mm	in.	mm	in.	mm	lbs.	kgs
766M							
1/2	15	8 1/8	206	4 1/4	108	20	9
3/4	20	9 1/16	230	4 3/4	121	30	13.6
1	25	10 11/16	271	5 3/4	146	52	23
1 1/4	32	12	305	6 3/4	171	64.5	29
1 1/2	40	12	305	6 3/4	171	64.5	29
2	50	13 15/16	354	7 1/2	191	93	42
2 1/2	65	17 1/2	445	10 3/4	273	185	84
3	80	17 1/2	445	10 3/4	273	185	84
4	100	23 3/4	591	15	381	334	151
5	125	—	—	—	—	—	—
6	150	30 5/8	778	20 1/2	521	770	350
8	200	39	991	26 15/16	684	1200	545
10	250	CF	CF	CF	CF	CF	CF
12	300	CF	CF	CF	CF	CF	CF

SIZE		DIMENSIONS				WEIGHT	
		A		B			
in.	mm	in.	mm	in.	mm	lbs.	kgs.
767							
1/2	15	12 5/8	321	7 1/16	195	30	13.6
3/4	20	12 5/8	321	7 1/16	195	40	18
1	25	12 5/8	321	7 1/16	195	65	29.5
1 1/4	32	16 7/8	429	10 1/2	267	140	63.5
1 1/2	40	16 7/8	429	10 1/2	267	140	63.5
2	50	18 15/16	481	12 1/2	318	240	109
2 1/2	65	25 3/4	654	18 13/16	478	500	227
3	80	26 3/4	679	18 13/16	478	560	254
4	100	33 5/8	854	20 1/4	514	850	386
5	125	—	—	—	—	—	—
6	150	33 3/4	857	20	508	1900	862
8	200	CF	CF	—	—	CF	CF
10	250	CF	CF	CF	CF	CF	CF
12	300	CF	CF	CF	CF	CF	CF

CF = Consult Factory

Limited Warranty: Mueller Steam Specialty warrants each product to be free from defects in material and workmanship under normal usage for a period of one year from the date of original shipment. In the event of such defects within the warranty period, the Company will, at its option, replace or recondition the product without charge. This shall constitute the sole and exclusive remedy for breach of warranty, and the Company shall not be responsible for any incidental, special or consequential damages, including without limitation, lost profits or the cost of repairing or replacing other property which is damaged if this product does not work properly, other costs resulting from labor charges, delays, vandalism, negligence, fouling caused by foreign material, damage from adverse water conditions, chemical, or any other circumstances over which the Company has no control. This warranty shall be invalidated by any abuse, misuse, misapplication or improper installation of the product. **THIS WARRANTY IS IN LIEU OF ALL OTHER WARRANTIES, EXPRESS OR IMPLIED, INCLUDING ANY IMPLIED WARRANTIES OF MERCHANTABILITY OR FITNESS FOR A PARTICULAR PURPOSE.** Any implied warranties that are imposed by law are limited in duration to one year.

Some States do not allow limitations on how long an implied warranty lasts, and some States do not allow the exclusion or limitation of incidental or consequential damages. Therefore the above limitations may not apply to you. This Limited Warranty gives you specific legal rights, and you may have other rights that vary from State to State. You should consult applicable state laws to determine your rights.



A WATTS Brand