

Materials

BILL OF MATERIAL MODELS 781, 781-WE		
ITEM	DESCRIPTION	MATERIAL
1	BODY	Carbon Steel ASTM A216 Grade WCB
2	COVER **	Carbon Steel ASTM A216 Grade WCB
3	SCREEN	304 SS
4	GASKET	Compressed Non-Asbestos
5	STUDS	A193 B7
6	NUTS	A194 2H

** Cover may be manufactured from equivalent grade plate material

Also Available:

Body/Cap: Carbon-Moly ASTM A217 Gr. WC1
 Chrome-Moly ASTM A217 Gr. WC6
 Chrome-Moly ASTM A217 Gr. WC9

Pressure Drop

See Pressure Drop Charts in Technical Data section of the Mueller Steam Specialty Engineering binder. Cv values are noted in the Dimensions and Weights table below.

Dimensions and Weights 781

SIZE		DIMENSIONS				WEIGHT			Cv			
in.	mm	A in.	mm	B in.	mm	C (NPT) in.	mm	D Screen Removal in.	mm	lbs.	kgs.	GPM
1/2	15	5 1/4	149	3 1/2	89	3/8	10	5	130	5.5	2.5	8
3/4	20	7 3/8	187	3 3/4	95	1/2	15	5	130	10.25	4.6	15
1	25	7 7/8	187	3 3/4	95	1/2	15	5	130	10.25	4.6	22
1 1/4	32	7	178	4 3/4	121	1/2	15	7	178	9.75	4.4	38
1 1/2	40	7 1/4	181	4 3/4	121	1/2	15	7	178	12.5	5.6	42
2	50	7 7/8	200	5 1/4	133	1/2	15	7	178	18	8.1	70
2 1/2	65	9 3/4	248	6 1/2	165	1	25	9 3/4	248	28	12.7	110
3	80	10 1/8	256	7	178	1	25	10	254	34	15	140
4	100	12 1/8	308	8 1/4	210	1 1/2	40	12	305	55	25	245
5	125	15 3/8	397	11 1/4	286	2	50	20	508	90	40	400
6	150	18 1/2	470	13 1/2	343	2	50	20	508	153	69	600
8	200	21 3/8	543	15 1/2	394	2	50	22 3/4	578	220	100	1,000
10	250	26	660	18 1/2	470	2	50	28	711	320	145	1,580
12	300	29 7/8	759	22 1/4	565	2	50	30	762	550	250	2,200
14	350	36	914	25	635	2	50	36 1/2	927	975	442	3,200
16	400	41 1/8	1056	26 1/2	673	2	50	42	1067	1635	741	4,900
18	450	46	1168	34 3/8	886	2	50	50 7/8	1292	2376	1078	6,100
20	500	49 1/2	1257	39	991	2	50	55 3/8	1407	2675	1213	8,000
24	600	58 3/8	1483	44 1/4	1122	2	50	67 1/4	1708	4880	2213	11,000

Dimensions and Weights 781WE

SIZE		DIMENSIONS				WEIGHT			Cv			
in.	mm	A in.	mm	B in.	mm	C (NPT) in.	mm	D Screen Removal in.	mm	lbs.	kgs.	GPM
1/2	15	6 3/8	168	3 1/2	89	3/8	10	5	130	3	1.3	8
3/4	20	8 9/16	211	3 3/4	95	1/2	15	5	130	9	4	15
1	25	8 9/16	257	3 3/4	95	1/2	15	5	130	9	4	22
1 1/4	32	10 3/8	260	5 1/4	133	1/2	15	7	178	12	5.4	38
1 1/2	40	10 3/4	279	5 1/4	133	1/2	15	7	178	13	5.9	42
2	50	10 3/4	219	5 1/4	133	1/2	15	7	178	10	4.5	70
2 1/2	65	10 5/8	269	6 1/2	165	1	25	9 3/4	248	14	6.3	110
3	80	12	305	7	178	1	25	10	254	20	9	140
4	100	14 1/2	368	8 1/4	210	1 1/2	40	12	305	40	18	245
5	125	19 7/16	491	13 1/2	343	2	50	20	508	90	40	400
6	150	19 7/16	491	13 1/2	343	2	50	20	508	90	40	600
8	200	23 3/8	594	15 3/4	400	2	50	22 3/4	578	168	76	1,000
10	250	27 3/8	695	19	483	2	50	28	711	250	113	1,580
12	300	32	813	22 1/2	565	2	50	30	762	440	200	2,200
14	350	36	914	25	635	2	50	36 1/2	927	815	370	3,200
16	400	41 1/8	1056	26 1/2	673	2	50	42	1067	1433	650	4,900
18	450	46	1168	34 3/8	886	2	50	50 7/8	1292	2152	976	6,100
20	500	49 1/2	1257	39	991	2	50	55 3/8	1407	2393	1085	8,000
24	600	58 3/8	1483	44 1/4	1122	2	50	67 1/4	1708	4486	2034	11,000

Apply for certified drawing

Limited Warranty: Mueller Steam Specialty warrants each product to be free from defects in material and workmanship under normal usage for a period of one year from the date of original shipment. In the event of such defects within the warranty period, the Company will, at its option, replace or recondition the product without charge. This shall constitute the sole and exclusive remedy for breach of warranty, and the Company shall not be responsible for any incidental, special or consequential damages, including without limitation, lost profits or the cost of repairing or replacing other property which is damaged if this product does not work properly, other costs resulting from labor charges, delays, vandalism, negligence, fouling caused by foreign material, damage from adverse water conditions, chemical, or any other circumstances over which the Company has no control. This warranty shall be invalidated by any abuse, misuse, misapplication or improper installation of the product. **THIS WARRANTY IS IN LIEU OF ALL OTHER WARRANTIES, EXPRESS OR IMPLIED, INCLUDING ANY IMPLIED WARRANTIES OF MERCHANTABILITY OR FITNESS FOR A PARTICULAR PURPOSE.** Any implied warranties that are imposed by law are limited in duration to one year.

Some States do not allow limitations on how long an implied warranty lasts, and some States do not allow the exclusion or limitation of incidental or consequential damages. Therefore the above limitations may not apply to you. This Limited Warranty gives you specific legal rights, and you may have other rights that vary from State to State. You should consult applicable state laws to determine your rights.



A WATTS Brand

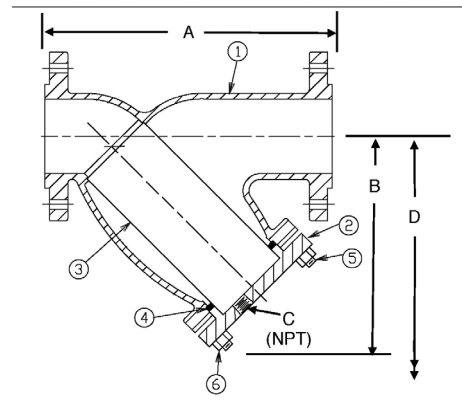

Model 781

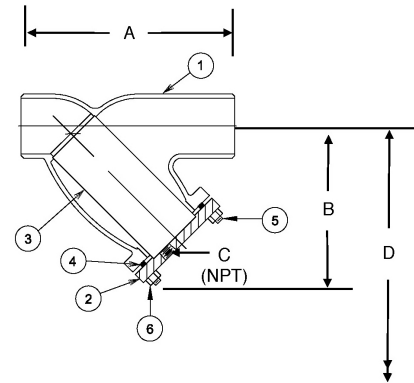

Model 781-WE