

Engineering Specification

Job Name _____

Contractor _____

Job Location _____

Approval _____

Engineer _____

Contractor's P.O. No. _____

Approval _____

Representative _____

Ball-Plex™ Cast Iron Flanged End Duplex Smart Strainer

791MFA SM, Class 125

2" – 6" (50 – 150 mm)

The 791MFA SM Duplex Basket Smart Strainer provides economical protection for costly pumps, meters, valves, and similar mechanical equipment by straining foreign matter from the piping system. Duplex strainers enable system maintenance to be performed without disrupting the flow.

Smart and Connected technology comes standard on the Model 791MFA SM duplex strainer with two pre-installed pressure sensors at the inlet and outlet of the strainer. These sensors monitor the pressure drop that occurs over time when a strainer screen becomes clogged by foreign particles. When the differential pressure across the strainer screen exceeds the pre-configured threshold, an alert is triggered to the customer informing that action is required.

NOTICE

An add-on Sensor Control Monitor & Connection Kit is required to activate the pressure monitoring capability and collect data from the sensors. Without the connection kit, the sensors are passive components that do not communicate with any other device. The add-on connection kit communicates over wired RS-485 MODBUS or BACnet connection and is compatible with most Building Management and Building Automation Systems. An alternate cellular communication gateway is available if no BMS is present; however, this option provides alerts only. Data streaming is not available.

NOTICE

The information contained herein is not intended to replace the full product installation and safety information available or the experience of a trained product installer. You are required to thoroughly read all installation instructions and product safety information before beginning the installation of this product.



Model 791MFA SM

PRESSURE/TEMPERATURE–NON-SHOCK

MODEL	MATERIAL	RATING
791MFA SM	Cast Iron	200 psi @ 32°F 13.8 bar @ 0°C 176 psi @ 248°F 12.1 bar @ 120°C

Note: Maximum temperature can be limited by gasket and seat material. Consult factory.

⚠ WARNING

Bolted covers required above 150 psi or 200°F.

Features

- Ball-Plex™ Duplex Strainers use 3-way ball valves as diverter valves.
- Each ball is made of 316 stainless steel for corrosion resistance, strength, and resistance to the buildup of solids on the surface of the ball.
- PTFE seats provide bubble-tight sealing, superior to metal seats in other designs. This eliminates potentially dangerous leakage into the chamber being cleaned.
- Two-part body casting allows true and easy in-line service.
- After removal of the cover and basket, all working parts are easily accessible even with the unit in line.
- The handle covers the pressurized chamber. This prevents accidental opening of the pressurized chamber, and allows easy access to the chamber being cleaned.



A WATTS Brand

Mueller Steam Specialty product specifications in U.S. customary units and metric are approximate and are provided for reference only. For precise measurements, please contact Mueller Steam Specialty Technical Service. Mueller Steam Specialty reserves the right to change or modify product design, construction, specifications, or materials without prior notice and without incurring any obligation to make such changes and modifications on Mueller Steam Specialty products previously or subsequently sold.

Available Features with Sensor Control Monitor Installed

- Real-time pressure monitoring
- Visual Display – Pressure and temperature data for each sensor, Screen Pressure differential, Screen fill percentage
- Data streaming if connected to BMS [RS-485 MODBUS or BACnet]
- Full basket alerts

Alerts

- Display
- LED
- BMS Alarm
- Cellular Gateway
- RS-485 MODBUS and BACnet



Typical Service

- Duplex Strainers are designed for use in fluid handling systems where the flow cannot be shut down for basket cleaning.
- Typical services include cooling water, compressors, condensers, fire lines, fuel lines, lubrication systems, salt and fresh water systems, chemical process systems, and pump suction service.
- Consider strainer body and screen material as well as gasket and seat materials for suitability in particular service.

Baskets

Large Open Area Ratios ensure minimum pressure drop across the unit.

Refer to the Technical Data section of the Mueller Steam Specialty Engineering binder for pressure drop charts.

Call customer service if you need assistance with technical details.

Screens

MODEL	SIZE	STANDARD (WATER)	
791	IN.	MATERIAL	OPENING
791MFA	2 – 4	304SS	0.062 perf
	5 – 6	304SS	0.125 perf

Materials

ITEM	791FA SM
Body	Cast Iron ASTM A126-B
Cover	Cast Iron ASTM A126-B
Seat	PTFE
O-ring	Buna-N
Pressure Sensor	Mixed Composite
Ball	Monel, Bronze, or Stainless Steel

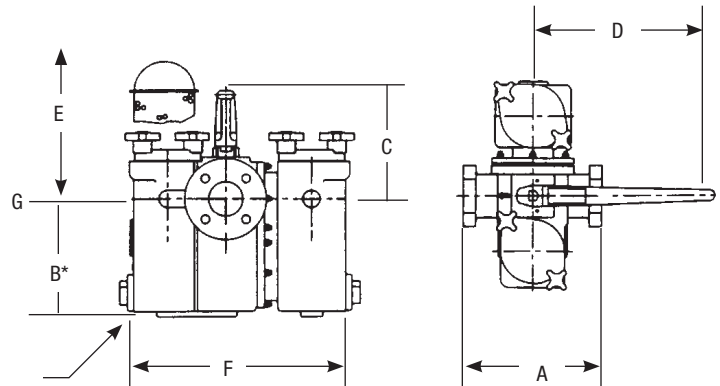

* "B" dimension includes the floor supports when applicable.

Model 791MFA SM

Dimensions and Weights

SIZE		DIMENSIONS										WEIGHT		PRESSURE SENSOR PORT				
		A		B		C		D		E SCREEN Removal		F		G (NPT)		H (792) (NPT)		
<i>in.</i>	<i>mm</i>	<i>in.</i>	<i>mm</i>	<i>in.</i>	<i>mm</i>	<i>in.</i>	<i>mm</i>	<i>in.</i>	<i>mm</i>	<i>in.</i>	<i>mm</i>	<i>in.</i>	<i>mm</i>	<i>lb</i>	<i>kg</i>	<i>in.</i>		
2	50	10 5/8	270	8 3/16	208	7 1/8	181	20	508	12 5/8	321	16 3/8	416	1 1/2	40	113	51.2	1/2
2 1/2	65	13 1/2	343	12	305	8 1/16	205	20	508	17 21/32	448	20 3/8	518	1 1/2	40	218	98.8	1/2
3	80	13 1/2	343	12	305	8 1/16	205	20	508	17 21/32	448	20 3/8	518	1 1/2	40	218	98.8	1/2
4†	100	16	406	16 13/16	427	15 1/2	394	14+	356	23 1/2	597	24 1/2	622	1 1/2	40	432	195.9	1/2
5†	125	22	559	18 5/8	473	17 1/4	438	14+	356	25 11/16	653	26 1/4	667	1 1/2	40	786	356.4	1/2
6†	150	22	559	18 5/8	473	17 1/4	438	14+	356	25 11/16	653	26 1/4	667	1 1/2	40	786	356.4	1/2

†4", 5", and 6" units are standard with a gear operator; the handwheel dimension is 10". Units also standard with floor supports; dimension "B" reflects this standard in those sizes.

How to order Mueller Steam Specialty

Model 792MFD SM, 794MFD SM, 796MFD SM

Example 4.0 792MFDH SM

This is a 4" Class 150 flanged duplex basket smart strainer with a carbon steel body and 316SS ball.

4.0 792MFDH SM

Size: _____

Model: _____

- 791 - Class 125
- 792 - Class 150
- 794 - Class 300
- 796 - Class 600
- 691 - Class 125 Large Diameter
- 692 - Class 150 Large Diameter

Connection: _____

- S - Screwed, Sizes ¾" – 1½"
- F - Flanged, Sizes ¾" – 1½"
- MF - Flanged, Sizes 2" – 16"

Body: _____

- A - Cast Iron
- B - Bronze
- D - Carbon Steel
- H - Stainless Steel

Ball: _____

- Q - Monel
- B - Bronze
- H - Stainless Steel

Option: _____

SM - Smart & Connected (includes pressure sensors, Sensor Control Monitor **sold separately**).



A WATTS Brand

