

Model: 861, 862, 861BC, 862BC

Job Name _____

Contractor _____

Job Location _____

Approval _____

Engineer _____

Contractor's P.O. No. _____

Approval _____

Representative _____

LEAD FREE***Cast Carbon and Alloy Steel Screwed & Socket****Weld End Y Strainers****Model: 861, 862, 861BC, 862BC****Sizes: ¼" - 3"**

PRESSURE/TEMPERATURE-NON-SHOCK		
Model	Material	Rating
861, 862, 861BC, 862BC	Carbon Steel	1480psi @ -20°F to 100°F 102.04 bar @ 37.78°C 640psi @ 850°F 44.13 bar @ 454.44°C
861, 862, 861BC, 862BC	Chrome Alloy	1500psi @ -20°F to 100°F 103.42 bar @ 37.78°C 975psi @ 850°F 67.22 bar @ 454.44°C

Screwed Cap

861 Screwed - Class 600

862 Socket - Class 600

Bolted Cap

861BC Screwed - Class 600

862BC Socket - Class 600

Features

- Machined seats in both body and cap align and lock the screen in place to stop sediment bypass
- Machined seats facilitate alignment and accurate reseating after servicing

Construction

- Straight threaded, gasketed cap is used for easy disassembly and assembly on models 861, 862. Many others use Loctite, rendering disassembly virtually impossible
- Models 861BC and 862BC are furnished with a removable bolted cap for easy maintenance
- Heavy duty, rugged bodies with extra heavy bore

Self-Cleaning

- Self-cleaning is accomplished by opening the plug or valve connected to the blowoff outlet

Blowoff Outlets

- Outlets are NPT tapped
- Sizes of tapping specified on next page
- Not normally furnished with plug. Plug available, specify with order
- Blind caps are also available, specify with order



Models 861BC, 862BC

Capacity

- Generously proportioned bodies
- Open Area Ratio much greater than pipe size, ensuring low pressure drop
- Minimum of 4 to 1 Open Area Ratio

Screens

MODEL	SIZES	STANDARD (WATER)		STEAM RECOMMENDATION	
		MATERIAL	OPENING	MATERIAL	OPENING
All	¼" - 3"	304SS	.062 perf	304SS	.033 perf

NOTICE

The information contained herein is not intended to replace the full product installation and safety information available or the experience of a trained product installer. You are required to thoroughly read all installation instructions and product safety information before beginning the installation of this product.

***The wetted surface of this product contacted by consumable water contains less than 0.25% of lead by weight.**

Mueller Steam Specialty product specifications in U.S. customary units and metric are approximate and are provided for reference only. For precise measurements, please contact Mueller Steam Specialty Technical Service. Mueller Steam Specialty reserves the right to change or modify product design, construction, specifications, or materials without prior notice and without incurring any obligation to make such changes and modifications on Mueller Steam Specialty products previously or subsequently sold.

A WATTS Brand

Materials

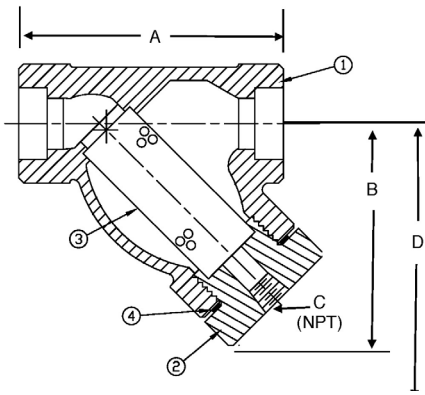

BILL OF MATERIAL MODELS 861, 862		
ITEM	DESCRIPTION	MATERIAL
1	BODY	Carbon Steel, ASTM A216 Grade WCB
2	CAP	Carbon Steel, ASTM 12L14
3	SCREEN	304 SS
4	GASKET	Spiral Wound SS, Graphite Filled

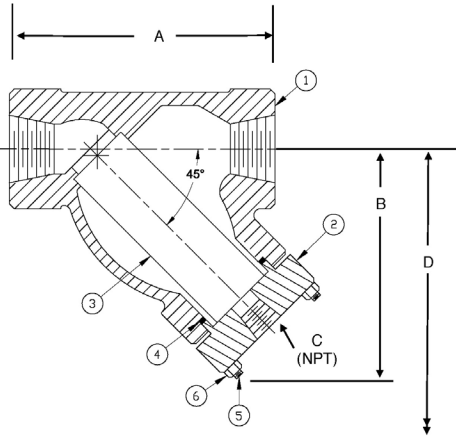

BILL OF MATERIAL - MODELS 861BC, 862BC		
ITEM	DESCRIPTION	MATERIAL
1	BODY	Carbon Steel ASTM A216 Grade WCB
2	COVER	SA516-70 Plate
3	SCREEN	304 SS
4	GASKET	Spiral Wound SS, Graphite Filled
5	STUDS	A193 B7
6	NUTS	A194 2H

ALSO AVAILABLE:

Body/Cap: Carbon-Moly ASTM A217 Gr. W1
 Chrome-Moly ASTM A217 Gr. WC6
 Chrome-Moly ASTM A217 Gr. WC9

Pressure Drop

See Pressure Drop Charts in Technical Data section of the Mueller Steam Specialty Engineering binder. Cv values are noted in the Dimensions and Weights table below.

Dimensions and Weights

SIZE	DIMENSIONS										SCREEN REMOVAL				WEIGHT				Cv		
	A		B		C (NPT)		D		E		F		861/862		861BC/862BC		Screwed			Bolted	
	in.	mm	in.	mm	in.	mm	in.	mm	in.	mm	in.	mm	in.	mm	in.	mm	lbs.	kg.		lbs.	kg.
1/4	3	76	2 1/2	64	1/4	6	3/8	10	9/16	14	CF	CF	2 5/8	66.6	CF	CF	1.5	.68	3	1.3	1
3/8	3	76	2 1/2	64	1/4	6	3/8	10	1 1/16	17.5	CF	CF	2 5/8	66.6	CF	CF	1.5	.68	3	1.3	2
1/2	3 29/32	99	3 1/16	78	1/4	6	3/8	10	7/8	21.7	3 1/4	83	3 7/8	98.4	5 1/4	130.5	2.3	1.02	3.3	1.4	8
3/4	4 1/4	108	3 5/8	92	3/8	10	1/2	13	1 1/16	27	4 1/4	108	4 1/2	114.3	6 1/4	158.7	3.8	1.7	4.3	1.9	15
1	4 15/16	125	4 1/4	108	1/2	15	1/2	13	1 5/16	33.8	4 5/8	117	5 1/2	139.7	7	177.8	6.5	2.9	7	3.1	22
1 1/4	5 5/8	143	4 9/16	109	3/4	20	1/2	13	1 11/16	42.5	5 1/2	140	5 7/8	146.9	8	203.2	8	3.6	10.3	4.6	38
1 1/2	6 1/4	159	5 3/16	132	3/4	20	1/2	13	1 5/16	48.6	6 1/4	159	7	177.8	9	228.6	10	4.5	16	7.2	42
2	7 1/2	191	6 1/8	156	1	25	5/8	16	2 3/8	61.1	7 1/4	184	8 1/2	215.9	11	279.4	14	6.3	21.8	9.8	70
2 1/2	12	305	N/A	NA	1 1/4	32	5/8	16	2 7/8	73.8	9 3/8	238	N/A	N/A	14	355.6	N/A	N/A	42.8	19	110
3	12	305	N/A	NA	1 1/4	32	5/8	16	3 9/16	89.8	9 3/8	238	N/A	N/A	14	355.6	N/A	N/A	43.3	19.6	140

Apply For Certified Drawings.

CF = Consult Factory

Limited Warranty: Mueller Steam Specialty warrants each product to be free from defects in material and workmanship under normal usage for a period of one year from the date of original shipment. In the event of such defects within the warranty period, the Company will, at its option, replace or recondition the product without charge. This shall constitute the sole and exclusive remedy for breach of warranty, and the Company shall not be responsible for any incidental, special or consequential damages, including without limitation, lost profits or the cost of repairing or replacing other property which is damaged if this product does not work properly, other costs resulting from labor charges, delays, vandalism, negligence, fouling caused by foreign material, damage from adverse water conditions, chemical, or any other circumstances over which the Company has no control. This warranty shall be invalidated by any abuse, misuse, misapplication or improper installation of the product. **THIS WARRANTY IS IN LIEU OF ALL OTHER WARRANTIES, EXPRESS OR IMPLIED, INCLUDING ANY IMPLIED WARRANTIES OF MERCHANTABILITY OR FITNESS FOR A PARTICULAR PURPOSE.** Any implied warranties that are imposed by law are limited in duration to one year.

Some States do not allow limitations on how long an implied warranty lasts, and some States do not allow the exclusion or limitation of incidental or consequential damages. Therefore the above limitations may not apply to you. This Limited Warranty gives you specific legal rights, and you may have other rights that vary from State to State. You should consult applicable state laws to determine your rights.



A WATTS Brand