

Engineering Specification

Job Name _____
 Job Location _____
 Engineer _____
 Approval _____

Contractor _____
 Approval _____
 Contractor's P.O. No. _____
 Representative _____

UL Listed Cast Iron Flanged End Y Strainers for Firelines

Models: 911U, Class 125

Sizes: 2½" – 12" (60 – 300mm)

Strainers provide economical protection for costly pumps, meters, valves, and other similar mechanical equipment by straining for-ign matter from the connected piping system.

Typical Service

These strainers are UL approved and are used to prevent clog-
 ging in fire service systems such as automatic sprinkler systems
 and various spray systems. *In accordance with UL Subject 321
 - Fireline Strainers, extra large baskets have a minimum open area
 ratio of 4 to 1.

Features

- Extra large capacity baskets equal very low pressure drop and long intervals between cleaning and servicing, essential in this service.
- NPT tapped blow-off connections are available on request.

Pressure Drop

Size	Pressure drop @ 15 ft/sec
2½"	2.31
3"	3.27
4"	3.18
5"	3.62
6"	3.59
8"	3.08
10"	3.29
12"	2.79

Screen

Size	Model	Standard (water)	
		Material	Opening
2½" – 12"	911U	304SS	.250 perf



Model 911U

Pressure/Temperature–Non-Shock

Model	Material	Rating CWP
911U	Cast Iron	175psi @ 150°F 12 bar @ 66°C 125psi @ 406°F

Material

911U	
Body	Cast Iron ASTM A126 Grade B
Cover	Steel ASTM A515 Grade 70
Gasket	Compressed Fiber

NOTICE

The information contained herein is not intended to replace the full product installation and safety information available or the experience of a trained product installer. You are required to thoroughly read all installation instructions and product safety information before beginning the installation of this product.



A WATTS Brand

Mueller Steam Specialty product specifications in U.S. customary units and metric are approximate and are provided for reference only. For precise measurements, please contact Mueller Steam Specialty Technical Service. Mueller Steam Specialty reserves the right to change or modify product design, construction, specifications, or materials without prior notice and without incurring any obligation to make such changes and modifications on Mueller Steam Specialty products previously or subsequently sold.

Dimensions and Weights

SIZE		DIMENSIONS						WEIGHT	
		A		B		C		SCREEN REMOVAL	
in.	mm	in.	mm	in.	mm	in.	mm	lbs.	kgs.
2½	60	14	356	10¼	260	14	356	60	27
3	80	14¾	375	10¾	273	15	381	65	29
4	100	17½	445	12 ¹³ / ₁₆	325	18	457	125	56
5	125	19¾	502	14½	368	20½	521	172	78
6	150	21 ⁵ / ₈	549	15 ⁷ / ₈	403	22	559	210	95
8	200	26	660	21½	546	30½	774.7	360	163
10	250	31	787	24¾	629	35½	902	610	277
12	300	37¼	946	29½	749	42½	1080	1045	475

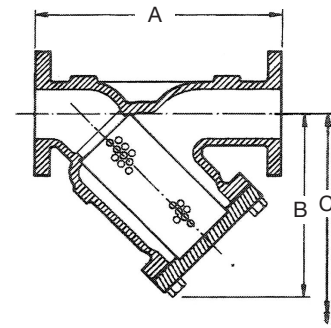

Model 911U

Apply for Certified Drawings

Limited Warranty: Mueller Steam Specialty warrants each product to be free from defects in material and workmanship under normal usage for a period of one year from the date of original shipment. In the event of such defects within the warranty period, the Company will, at its option, replace or recondition the product without charge. This shall constitute the sole and exclusive remedy for breach of warranty, and the Company shall not be responsible for any incidental, special or consequential damages, including without limitation, lost profits or the cost of repairing or replacing other property which is damaged if this product does not work properly, other costs resulting from labor charges, delays, vandalism, negligence, fouling caused by foreign material, damage from adverse water conditions, chemical, or any other circumstances over which the Company has no control. This warranty shall be invalidated by any abuse, misuse, misapplication or improper installation of the product. **THIS WARRANTY IS IN LIEU OF ALL OTHER WARRANTIES, EXPRESS OR IMPLIED, INCLUDING ANY IMPLIED WARRANTIES OF MERCHANTABILITY OR FITNESS FOR A PARTICULAR PURPOSE.** Any implied warranties that are imposed by law are limited in duration to one year.

Some States do not allow limitations on how long an implied warranty lasts, and some States do not allow the exclusion or limitation of incidental or consequential damages. Therefore the above limitations may not apply to you. This Limited Warranty gives you specific legal rights, and you may have other rights that vary from State to State. You should consult applicable state laws to determine your rights.



A WATTS Brand