

For Commercial and Industrial Applications

Job Name _____

Contractor _____

Job Location _____

Approval _____

Engineer _____

Contractor's P.O. No. _____

Approval _____

Representative _____

LEAD FREE*

Series 77SI
Wye-Pattern Cast Iron
Threaded Strainers

Sizes: 1/4" – 3" (8-80mm)

The Series 77SI Threaded, Wye-Pattern, Cast Iron Strainers are manufactured overseas. These strainers are designed to protect system components from dirt, rust, and other damaging debris in the piping system. Series 77SI strainers are used in steam and liquid applications. They are furnished with a machined seat that allows the screen to be self-aligning to assure a perfect fit. All sizes come with a PTFE gasket, threaded screen retainer cap, tapped blowdown connection, and an easily removable stainless steel screen.



No. 77SI

Features

- Cast iron body
- Wye-pattern
- Tapped retainer cap
- Threaded connections

Pressure – Temperature

Maximum Working Pressure:

400psi (27.6 bar) at 150°F (66°C) WOG

250psi (17.2 bar) at 406°F (208°C) WSP

Specifications

A wye-pattern cast iron strainer to be installed as indicated on the plans. The strainer must have a tapped retainer cap and threaded end connections. Strainer shall be rated to 400psi (27.6 bar) at 150°F (66°C) WOG; 250psi (17.2 bar) at 406°F (208°C) WSP. Strainer shall be a Watts Series 77SI.

Materials

- Body:** Cast iron
- Retainer Cap:** Cast iron
- Standard Screen:** 1/4" – 2" (8-50mm): 304 stainless steel #20 mesh,
 2 1/2"- 3" (65-80mm): 3/64" (1.2mm) 304 stainless steel perforated screen
- Gasket:** Graphite

NOTICE

The information contained herein is not intended to replace the full product installation and safety information available or the experience of a trained product installer. You are required to thoroughly read all installation instructions and product safety information before beginning the installation of this product.

***The wetted surface of this product contacted by consumable water contains less than 0.25% of lead by weight.**

Watts product specifications in U.S. customary units and metric are approximate and are provided for reference only. For precise measurements, please contact Watts Technical Service. Watts reserves the right to change or modify product design, construction, specifications, or materials without prior notice and without incurring any obligation to make such changes and modifications on Watts products previously or subsequently sold.



Performance Data

Table shows flow rates (gpm) at various pressure drops (psi) for 77SI strainers using standard screens.

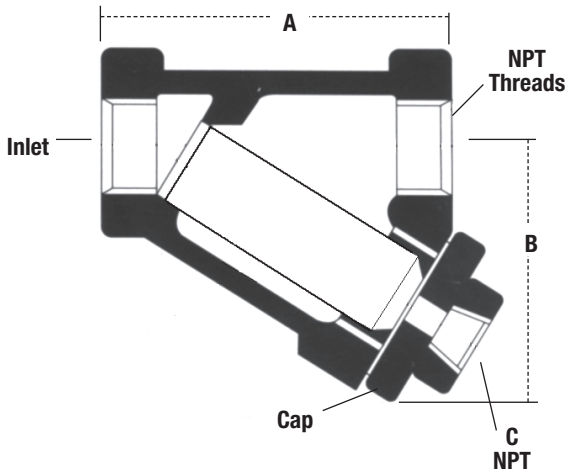
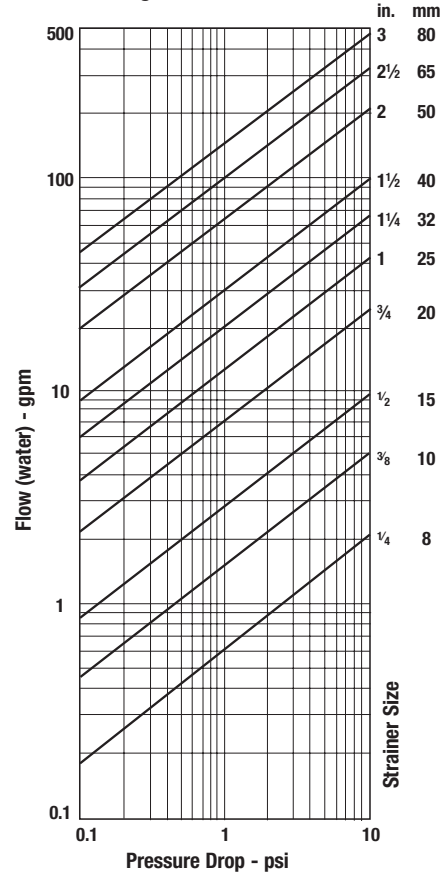

Dimensions — Weights

| SIZE (DN) | | DIMENSIONS | | | | | | WEIGHTS | |
|-----------|----|------------|-----|--------|-----|---------|----|---------|------|
| in. | mm | A | | B | | C (NPT) | | lbs. | kgs. |
| | | in. | mm | in. | mm | in. | mm | | |
| 1/4 | 8 | 3 3/16 | 81 | 2 1/16 | 52 | 1/4 | 8 | 1.5 | 0.7 |
| 3/8 | 10 | 3 3/16 | 81 | 2 1/16 | 52 | 1/4 | 8 | 1.5 | 0.7 |
| 1/2 | 15 | 3 3/16 | 81 | 2 1/16 | 52 | 1/4 | 8 | 1.5 | 0.7 |
| 3/4 | 20 | 3 3/4 | 95 | 2 1/16 | 62 | 3/8 | 10 | 2.5 | 1.1 |
| 1 | 25 | 4 | 102 | 2 1/16 | 62 | 3/8 | 20 | 3.0 | 1.4 |
| 1 1/4 | 32 | 5 | 127 | 3 3/8 | 86 | 3/4 | 20 | 5.5 | 2.5 |
| 1 1/2 | 40 | 5 3/4 | 146 | 3 7/8 | 98 | 3/4 | 20 | 8.0 | 3.6 |
| 2 | 50 | 7 | 178 | 4 3/4 | 121 | 1 | 20 | 13.0 | 5.9 |
| 2 1/2 | 65 | 9 1/4 | 235 | 5 7/8 | 149 | 1 | 25 | 22.0 | 10.0 |
| 3 | 80 | 10 | 254 | 6 | 152 | 1 1/4 | 40 | 30.0 | 13.6 |

Flow-coefficient

The flow coefficient (Cv) is the number of gallons per minute of water flowing through a given size restriction at a pressure drop on one psi. To obtain the Cv factor for a given size strainer, read capacity at intersection with the one (1) psi pressure drop.

Conversions: For gpm to lpm, multiply by 3.8
For psi to bars, multiply by .069

