

For Commercial and Industrial Applications

Job Name _____

Contractor _____

Job Location _____

Approval _____

Engineer _____

Contractor's P.O. No. _____

Approval _____

Representative _____

LEAD FREE*

Series 77F-CSSI Stainless Steel, Flanged, Wye-Pattern Strainers

Sizes: ½" – 6"

Series 77F-CSSI Stainless Steel, Flanged, Wye-Pattern Strainers are used in liquid and steam applications. They are furnished with blowdown connections and a machined seat that allows the screen to be self-aligning and assures a perfect fit.

All sizes come complete with a bolted screen retainer cover and PTFE gasket. Screen cover is tapped for strainer clean out by removing the blowdown plug or opening a blowdown valve piped to the blowdown outlet. The strainer may be installed in horizontal or vertical pipe with the blowdown connection at the lower end of the screen retainer cover.

Features

- Stainless steel body
- Wye-pattern
- Self-aligning stainless steel screen
- Screen retainer cover tapped and plugged

Pressure (Non-Shock)-Temperature

Maximum Working Pressure:

150psi (10.3 bar) at 400°F (204°C) WSP

275psi (19.0 bar) at 100°F (38°C) WOG

Materials

Body:	ASTM A-351 Grade CF8M Type 316 stainless steel
Plug:	ASTM A-182 Type 316 stainless steel
Screen:	304 stainless steel
Screen Retainer Cover:	ASTM A-351 Grade CF8M Type 316 stainless steel
Gasket:	PTFE



77F-CSSI

NOTICE

The information contained herein is not intended to replace the full product installation and safety information available or the experience of a trained product installer. You are required to thoroughly read all installation instructions and product safety information before beginning the installation of this product.

NOTICE

Inquire with governing authorities for local installation requirements

*The wetted surface of this product contacted by consumable water contains less than 0.25% of lead by weight.



Watts product specifications in U.S. customary units and metric are approximate and are provided for reference only. For precise measurements, please contact Watts Technical Service. Watts reserves the right to change or modify product design, construction, specifications, or materials without prior notice and without incurring any obligation to make such changes and modifications on Watts products previously or subsequently sold.



Standard Screens

SIZE		OPENINGS		STANDARD SCREENS
in.	in.	mm		
1/2 - 1 1/2	0.032	0.813		1/32 304SS perf.
2 - 3	0.045	1.143		3/64 304SS perf.
4 - 6	0.125	3.175		1/8 304SS perf.

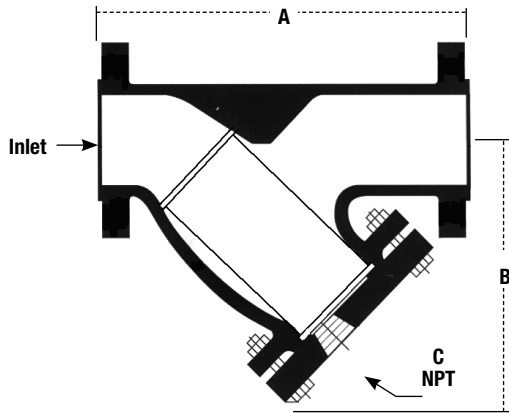

Dimensions – Weights

SIZE	DIMENSIONS						WEIGHT	
	A		B		C (NPT)		lbs.	kgs
in.	in.	mm	in.	mm	in.	mm		
1/2	6	152	3 3/8	98	1/4	8	6	2.4
3/4	7	178	4 1/4	108	3/8	10	7	2.9
1	7 1/2	191	4 3/4	121	1/2	15	9	4.0
1 1/2	9	229	5 5/8	143	1/2	15	12	5.4
2	8 5/8	219	5 1/4	133	1/2	15	20	9.0
2 1/2	10 1/4	260	7 1/2	191	3/4	20	32	14.5
3	11 5/8	295	7	195	1	25	36	16.3
4	14 3/8	365	9 1/8	232	1 1/2	40	61	27.6
6	18 5/8	473	13	330	2	50	160	72.5

Dimensions shown are subject to change. Contact Watts for exact dimensions.

Performance Data

Table shows flows (gpm-water) at various pressure drops (psig) using standardly furnished screens.

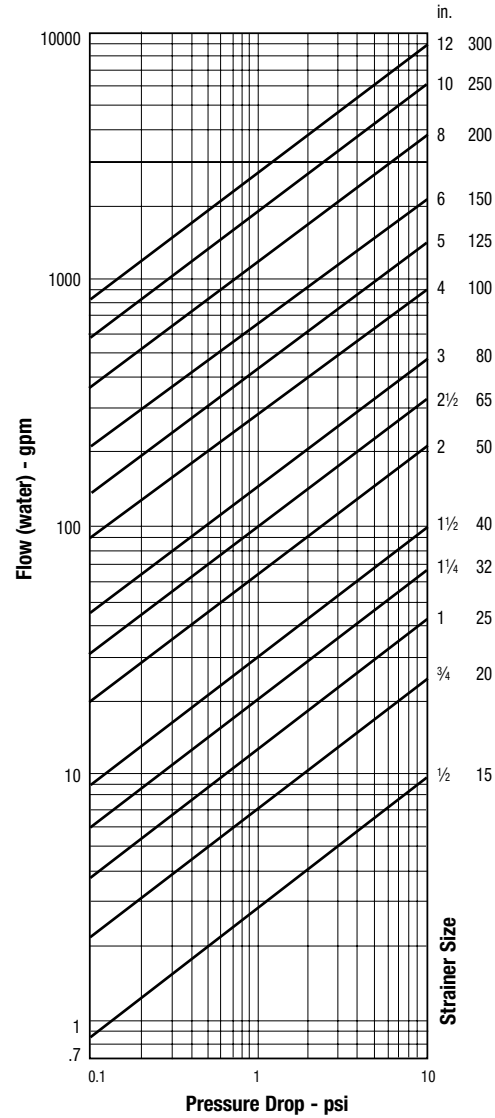

Flow-coefficient

The flow coefficient (C_v) is the number of gallons per minute of water flowing through a given size restriction at a pressure drop of one psi. To obtain the C_v factor for a given size strainer, read capacity at intersection with the one (1) psi pressure drop.

Conversions: For gpm to lpm, multiply by 3.8
For psi to bars, multiply by .069

