

# Technical Data

## Oil Mist Discharge Filters

### Applications & Equipment

- Vacuum Pumps & Systems
- Vacuum Furnaces & Ovens
- Vacuum Freeze Drying & Outgassing
- Vacuum Metalizing
- Vacuum Drying
- Vacuum Coating
- Custom Vacuum Pumping Systems
- Food Processing & Packaging
- Industrial Vacuum Processes
- Pressure Unloading Vents on Piston Compressors
- Medical Work Areas
- Industrial Aerosol Scrubbing
- Heat Treating Equipment
- Vacuum Hold Down
- Routing Equipment
- Laboratory Industry
- Leak Detectors
- Autoclaving, Sterilization
- Reciprocating Engines
- Crankcase Ventilation Systems

### Identification

Standard Solberg assemblies should have an identification label/nameplate that gives the following information:

- Assembly Model #
- Replacement Element #

The part number designates the filter type, the element configuration and housing connection size. For example, the following part number identifies the filter as being an “HDL” design filter with a “PSG344/2” coalescing element, and 3” MPT connection size.

#### **HDL-PSG344/2-300**

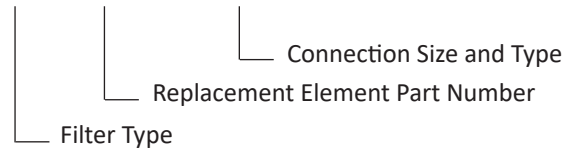

### Installation & Maintenance

Mounting orientation is typically top-up vertical, so draining can occur. See figure below for proper installation method. Request the appropriate maintenance manual from your Solberg representative or through [www.solbergmfg.com](http://www.solbergmfg.com).

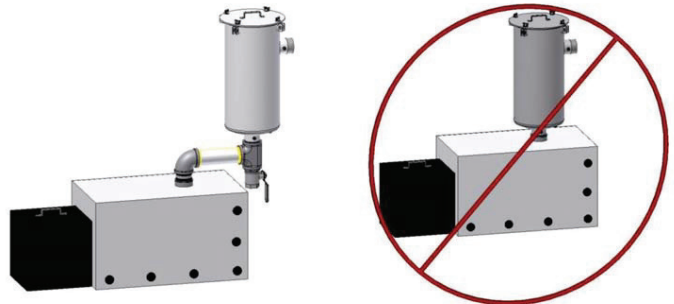

Rev: US0621K

## General

Coalescing air/oil separation technology is highly effective at capturing oil mist from the exhaust of an oil sealed/lubricated vacuum pump and keeping surrounding work environments clean and safe. Each pump technology produces its own specific oil discharge characteristics and requires the appropriate housing and element configuration to optimize performance.

Critical factors that influence performance of a coalescing air/oil separator include quality of the oil, equipment type, oil type and viscosity, challenge rate, process gas characteristics, operating temperature, operating vacuum level, and maximum air flow rating of the pump. Because of these variables, it is always best to work with Solberg personnel when selecting and sizing a vacuum pump discharge filter. However, Solberg's standard product lines will perform well in most general duty applications. The following guidelines will help when selecting a standard product.

### Filter Selection Guidelines

**#1:** Protect the pump with adequate inlet filtration. Contaminants such as particulates, water, and solvents can damage the pump internals and significantly reduce the effectiveness of the discharge filter.

**#2:** Identify the type of vacuum pump oil being used. Solberg's standard coalescing technology works well with most commercially available vacuum pump oils across a broad range of viscosities. Generally, maximum coalescing effectiveness is achieved with temperatures at the inlet of the filter: at or below 160°F (~70°C) for mineral oils, at or below 180°F (~ 82°C) for synthetics. For best results, consult with the factory and provide information on operating temperature and viscosity/grade of oil prior to making any filter selection.

**#3:** Determine the filter size based on the flow rating of the pump at atmospheric conditions, not the connection size. An undersized coalescing filter will cause increased back pressure and negatively affect pump performance.

**#4:** To capture oil, the coalescing element must receive the oil challenge in an aerosol form. If the oil is in a vapor state, it will pass through the coalescing media. Generally, the coalescing technology will perform more effectively at lower operating temperatures. In many cases, adding distance between the pump and the filter will help to lower the air stream temperature and improve coalescing effectiveness.

**#5:** Install in external environments where temperatures will not fall below freezing or exceed 100°F (37°C). Creating distance between the pump and the exhaust filter is desirable, however, avoid installing long pipe runs and horizontal sections where condensed oil can accumulate. When possible, install a drip-leg to gather any excess oil within the piping.

**#6:** Drain the filter and drip-leg to ensure your vacuum system performs at optimal levels. If the system is not drained regularly, issues such as high back pressure and unsafe working conditions can occur.

Once as much information as possible has been obtained, send the data to Solberg for review, review our data sheets, or visit our website, [www.solbergmfg.com](http://www.solbergmfg.com).

Rev: US0621K



For more information:

WEB: [FLTR.com.au](http://FLTR.com.au) PHONE: (+61) 1300 62 4020 EMAIL: [info@FLTR.com.au](mailto:info@FLTR.com.au) SKYPE: Purple.Engineering

# Hydraulic Breathers

## HB Series 1/4" - 2"

### Overview

Solberg's breathers are designed to protect hydraulic tanks, lube oil reservoirs, gearboxes and other enclosures that need bidirectional venting. Our line of breathers improve flow dynamics, reduce noise, help maintain fluid purity, and minimize oil migration to the surrounding environment. Keep your system free of contaminants and maximize uptime with Solberg's breathers.

### Benefits

- Toolless design
- Ease of maintenance
- Equipment protection
- Noise reduction
- Compact designs

### Features

- Integrated gasket seal
- High-efficiency polyester media
- Integrated rain cap and metal inlet tube design minimizes the potential for moisture migration during wash down
- Corrosive resistant black powder coat carbon steel
- Integrated silencing tubes for noise reduction

### Technical Specifications

- Temp (continuous): min -15°F (-26°C) max 220°F (104°C)
- Breather change out differential: 15-20" H<sub>2</sub>O over initial ΔP
- Pressure drop graphs available upon request
- Polyester: 99% removal efficiency
  - Cylindrical style cartridge 5 micron rating
  - Hockey Puck style cartridge 10 micron rating



Rev: US0621K

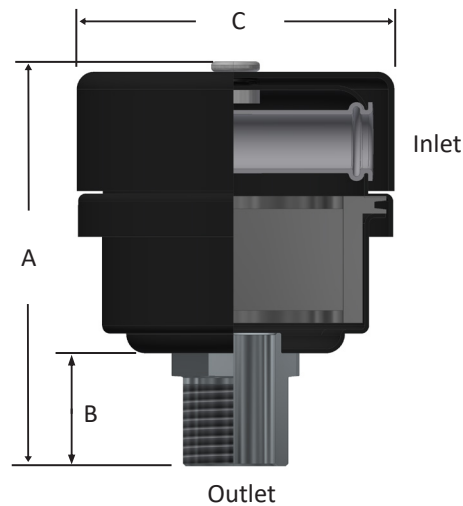

### Hockey Puck Style Cartridge

MPT Outlet	Flow Rating SCFM	Assembly Part Number	Dimensions - inches			Suggested Service ht. inches	Approx. Weight (lbs.)	Replacement Element Part No.
			A	B	C			
¼"	4	HB-05-025	2 7/8	1 1/16	2 1/2	1	0.25	05™
⅜"	8	HB-05-038	2 7/8	1 1/16	2 1/2	1	0.25	05™
⅜"	8	HB-07-038	3 5/8	1 1/16	3 1/4	2	0.50	07™
½"	8	HB-05-050	3 1/8	7/8	2 1/2	1	0.25	05™
½"	12	HB-07-050	4	7/8	3 1/4	2	0.50	07™
½"	12	HB-11-050	4 1/4	7/8	5	2	1	11™
¾"	12	HB-07-075	4 1/4	1 1/4	3 1/4	2	0.50	07™
¾"	25	HB-11-075	4 5/8	1 1/4	5	2	1	11™
1"	35	HB-11-100	4 5/8	1 1/4	5	2	1	11™

### Cylindrical Style Cartridge

MPT Outlet	Flow Rating SCFM	Assembly Part Number	Dimensions - inches			Suggested Service ht. inches	Approx. Weight (lbs.)	Replacement Element Part No.
			A	B	C			
1"	35	HB-15-100	4	1 1/4	6	3	2	15™
1 1/4"	70	HB-19P-125	6 3/4	1 5/8	6	5	3	19P®
1 1/2"	85	HB-19P-150	6 3/4	1 5/8	6	5	4	19P®
2"	135	HB-31P-200	7 1/2	2 1/4	10	10	14	31P™

### Options

- High vibration designs
- Custom connections
- Equipment specific configurations
- Multiple filter media types available

Rev: US0621K