

# Vacuum Traps

## VTL / VTS Series NW16 - NW50

### Overview

Solberg's vacuum traps can be used to protect a variety of vacuum pump technologies from particulate, liquid, aerosol and vapour contaminants migrating from a process. Multiple insert options and configurations are available to ensure pumps are properly protected. The trap minimizes pump oil contamination resulting in significantly fewer oil changeouts and reduced maintenance costs.

### Benefits

- Prevent back streaming
- Remove hydrocarbons
- Trap condensable vapours
- Reduce overall maintenance costs
- Chemical resistant
- Easy maintenance

### Features

- All stainless steel construction
- No tools needed to separate housing hemispheres with the quick release v-band for ease of maintenance
- Integrated drain port
- Connections available NW16, 25, 40, 50

### Technical Specifications

- Vacuum service down to  $1 \times 10^{-3}$  mbar
- Leak rate:  $1 \times 10^{-7}$  mbar L/sec
- Temperature range -20°C to 150°C
- Fine bead blast finish
- Viton O-ring



**VTL Series**



**VTS Series**

Rev: EU2402C2

## Standard Configurations:

### Stainless Steel Metal Wool

- Trap hydrocarbons and large particulate
- Replaceable stainless steel or copper insert
- Reduce contamination

### Molecular Sieve

- Trap water vapour and other gases
- Rechargeable 13X Zeolite desiccant
- Integral 120 VAC or 240 VAC regeneration heater
- Reduce oil change-out

## Options (contact factory):

### Chemical Adsorbents

- Trap chemicals and corrosives
- Chemical compatible adsorbents available (ie: activated carbon, alumina, SodaSorb, etc.)
- Reduce hazards

### Fine Particulate

- Trap fine particulate
- Multiple media available (down to .2 micron at 99.99% efficiency)
- Reduce dust and particle ingestion

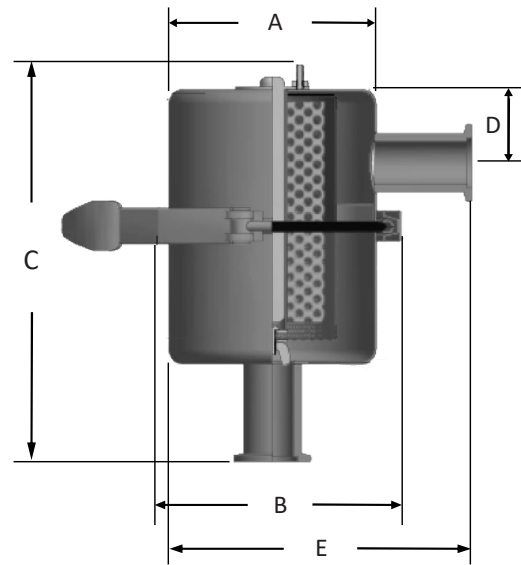

**VTL Configuration**

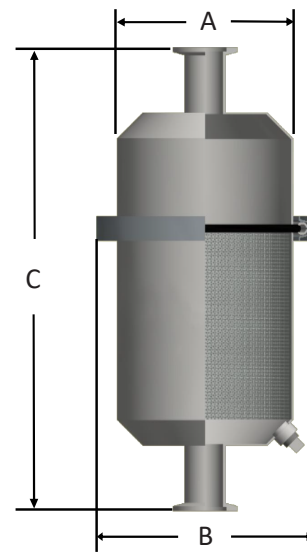

**VTS Configuration**

Assembly Part Number	VTL Housing Size	Dimensions - mm				
		A	B	C	D	E
VTL-SSM4-NW16S1	4"	102	135	245	38	168
VTL-SSM4-NW25S1	4"	102	135	245	38	168
VTL-SSM6-NW40S1	6"	155	183	248	64	211
VTL-MS4-NW25S1	4"	102	133	206	38	168
VTL-MS4-NW40S1	4"	102	133	206	32	168
VTL-MS6-NW50S1	6"	155	152	266	57	211

Assembly Part Number	VTS Housing Size	Dimensions - mm		
		A	B	C
VTS-SSM4-NW16S1	4"	102	135	285
VTS-SSM4-NW25S1	4"	102	135	285
VTS-SSM6-NW40S1	6"	155	180	293

**NOTE :** When unable to achieve base pressure, the operator should regenerate the sieve by turning on the heater for a few hours and running the mechanical pump with its ballast valve open. The frequency and duration of sieve regeneration depends on the kind and amount of gas(es) produced by the particular application.

Rev: EU2402C2