



F100 SERIES

In line high pressure filters (elements according to DIN 24550)

Inline filters for operating pressure up to 100 bar, flow rate up to 400 l/min.

Available with or without bypass, indicator port is a standard option to fit a visual or electrical differential indicator.



HOUSING	tested according to NFPA T3.10.5.1, ISO 10771, ISO 3968
PRESSURE:	Max operating: F100 XD040-063-100: 100 bar F100 XD160-250-400. 80 bar Burst: F100 XD040-063-100: 300 bar F100 XD160-250-400: 200 bar
CONNECTIONS:	G 1/2" ÷ 1 1/2"
MATERIALS:	Head: aluminium alloy Bowl: aluminium alloy Seal: NBR (FKM on request)
BYPASS VALVE:	No by-pass or 6 bar setting

ELEMENT	tested according to ISO 11170, 2941, 2942, 2943, 3724, 3968, 16889, 16908, 23181
FILTER MEDIA:	Glassfiber: G03 - G06 - G10 - G15 - G25 Paper: C10
COLLAPSE PRESSURE:	21 bar 210 bar

TEMPERATURE RANGE:	with NBR seal from -30 °C to +100 °C with FKM seal (OPTION) from -25 °C to +120 °C
FLUID COMPATIBILITY:	Full with HH-HL-HM-HV HETG-HEES (acc. to ISO 6743/4). For use with other fluid please contact Filtrac Customer Service (info@filtrac.it).

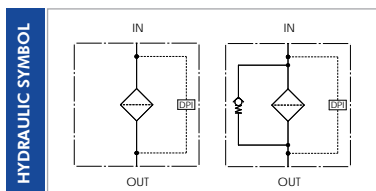

For more information:

WEB: FLTR.com.au PHONE: (+61) 1300 62 4020 EMAIL: info@FLTR.com.au

OVERALL DIMENSIONS

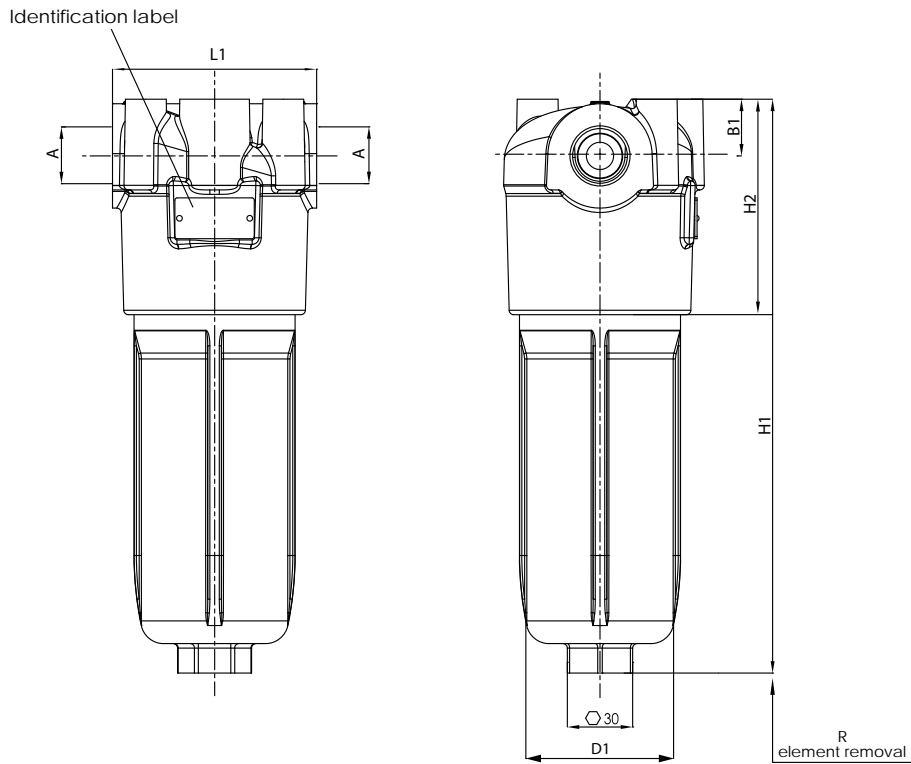

F100-XD160/250/400

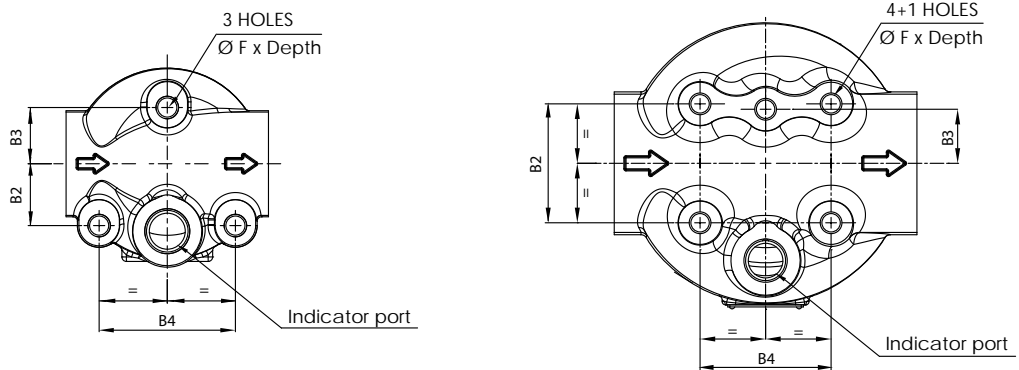

NOMINAL SIZE

MODEL	A	B1	B2	B3	B4	D1	F	H1	H2	L1	R	WEIGHT
F100-XD040	G 1/2"							183				1,45 Kg
F100-XD063	G 3/4"	25	27,5			65		253	95	90	110	1,55 Kg
F100-XD100	G 1"							332				1,8 Kg
F100-XD160				25	60,6		M10x15	289				3,7 Kg
F100-XD250	G 1 1/4"	40	55			110		361	129	140	130	4,4 Kg
F100-XD400	G 1 1/2"							514				5,6 Kg

ORDERING INFORMATION

	1.	2.	3.	4.	5.	6.	7.	8.	9.	10.
	F100	XD	100	G10	A	B	B3	D	W	000
SPARE ELEMENT	XD	100	G10	A						

1. FILTER SERIES	F100		
2. FILTER ELEMENT SERIES	XD		
3. FILTER SIZE	040-063-100		
	160-250-400		
4. FILTER MEDIA <small>For different media options please check availability with Filtrec Customer Service.</small>	000	no element	
	G03	glassfiber $\beta_{5\mu\text{m(c)}} \geq 1.000$	
	G06	glassfiber $\beta_{7\mu\text{m(c)}} \geq 1.000$	
	G10	glassfiber $\beta_{12\mu\text{m(c)}} \geq 1.000$	
	G15	glassfiber $\beta_{17\mu\text{m(c)}} \geq 1.000$	
	G25	glassfiber $\beta_{22\mu\text{m(c)}} \geq 1.000$	
	C10	paper $\beta_{10\mu\text{m(c)}} \geq 2$	only for element collapse Dp 21bar
5. ELEMENT COLLAPSE	A	21 bar	
	B	210 bar	recommended with no by-pass option
6. SEALS	B	NBR	
	V	FKM (on request)	
7. CONNECTIONS <small>For different thread options please check availability with Filtrec Customer Service.</small>	B3	G 1/2"	
	B4	G 3/4"	for sizes 040-063-100
	B5	G 1"	
	B6	G 1 1/4"	for sizes 160-250-400
	B7	G 1 1/2"	
8. BYPASS VALVE	0	no by-pass	
	D	6 bar	
9. INDICATOR PORT OPTION	S	with metal plug	
	W	with plastic plug	
10. COMPULSORY FIELD	000	Filtrec standard	

ACCESSORIES

The accessories must be ordered separately

INDICATOR	000	no indicator	
<small>(Y and F) digit for FKM seal option For other options see clogging indicators catalogue</small>	V05 (VY5)	differential visual 5 bar	
	E05 (EF5)	differential electrical 5 bar	
	E05L (EF5L)	differential electric 5 bar + *LC24	
	VEF5	differential visual and electric 5 bar	
	V08 (VY8)	differential visual 8 bar	
	E08 (EF8)	differential electrical 8 bar	recommended for no by-pass option
	E08L (EF8L)	differential electric 8 bar + *LC24	
	VEF8	differential visual and electric 8 bar	
	*LC24	LED connector	

For more information:

WEB: FLTR.com.au PHONE: (+61) 1300 62 4020 EMAIL: info@FLTR.com.au

PRESSURE DROP (Δp) INFORMATION FOR FILTER SIZING

The total Delta P through a filter assembly is given from Housing Δp + Element Δp .

This ideally should not exceed 1,0 bar and should never exceed 1/3 of the set value of the by-pass valve. N.B. All the reported data have been obtained at our laboratory, according to specification ISO3968 with mineral oil having 32 cSt viscosity and density 0,875 Kg/dm³.

HOUSING PRESSURE DROP

The housing Δp is given by the curve of the considered model and port, in correspondence of the flow rate value.

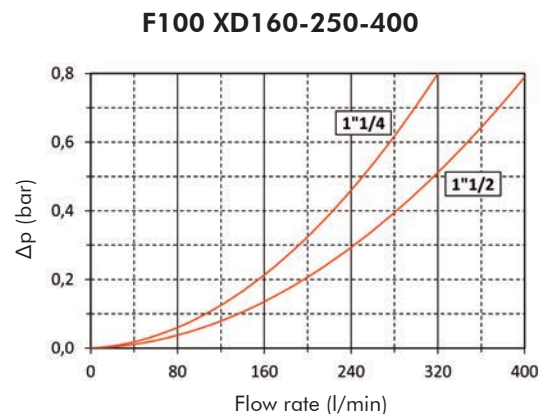
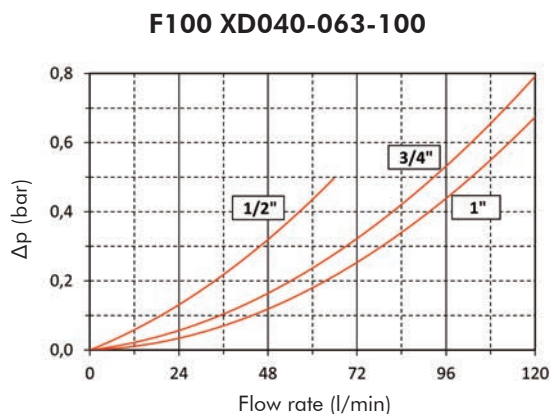

ELEMENT PRESSURE DROP (filter elements 21 bar collapse)

The element Δp (bar) is given by the flow rate (l/min) multiplied by the factor in the table here below corresponding to the selected media and divided by 1000.

If the oil has a viscosity V_x different than 32 cSt a corrective factor $V_x/32$ must be applied.

Example: 80 l/min with XD063G25A and oil viscosity 46 cSt: $(80 \times 4,15)/1000 \times (46/32) = 0,48$ bar

	G03A	G06A	G10A	G15A	G25A	C10A
XD040	15,40	13,5	7,88	6,75	5,63	5,00
XD063	11,31	9,00	5,54	4,85	4,15	3,85
XD100	8,40	5,85	3,6	3,15	2,70	2,00
XD160	5,47	4,47	2,63	1,84	1,49	0,94
XD250	3,64	2,61	1,68	0,91	0,86	0,58
XD400	2,28	1,52	1,12	0,64	0,57	0,36

EXAMPLE OF TOTAL Δp CALCULATION

F100XD063G25ABB5DW000 with 80 l/min and oil 46 cSt:

Housing Δp 0,3 bar + element Δp 0,48 bar $(80 \times 4,15/1000 \times 46/32) =$ total assembly Δp 0,78 bar

ELEMENT PRESSURE DROP (filter elements 210 bar collapse)

The element Δp (bar) is given by the flow rate (l/min) multiplied by the factor in the table here below corresponding to the selected media and divided by 1000.

If the oil has a viscosity V_x different than 32 cSt a corrective factor $V_x/32$ must be applied.

Example: 80 l/min with XD100G25B and oil viscosity 46 cSt: $(80 \times 4,95)/1000 \times 46/32 = 0,57$ bar

	G03B	G06B	G10B	G15B	G25B
XD040	24,48	22,50	14,63	12,38	10,10
XD063	20,46	16,62	10,38	8,65	6,92
XD100	13,30	10,35	6,75	5,85	4,95
XD160	5,69	4,74	3,37	2,81	2,25
XD250	3,78	3,06	2,52	2,16	1,80
XD400	2,36	1,94	1,57	1,29	1,01

EXAMPLE OF TOTAL Δp CALCULATION

F100XD100G25BBB5DW000 with **80 l/min** and oil **46 cSt** :

Housing Δp 0,3 bar + element Δp 0,57 bar $(80 \times 4,95/1000 \times 46/32) =$ total assembly Δp 0,87 bar

BYPASS VALVE PRESSURE DROP

The bypass valve Δp is given by the curve of the considered model and setting, in correspondence of the flow rate value.

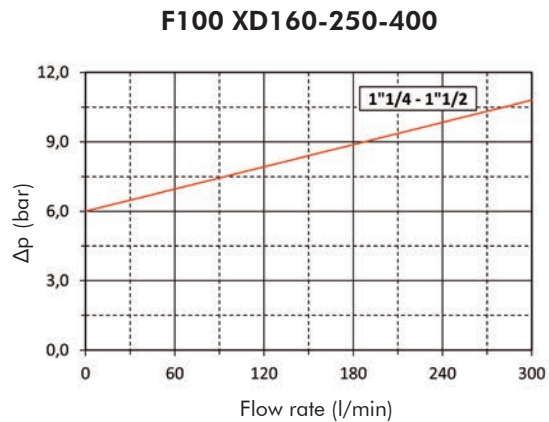
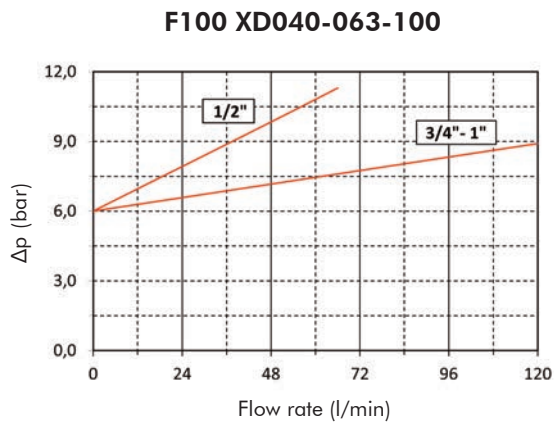

N.B. All the reported data have been obtained at our laboratory, according to specification ISO3968 with mineral oil having 32 cSt viscosity and density 0,875 Kg/dm³.

USER TIPS



INDICATOR TIGHTENING TORQUE

50 Nm

SPARE SEAL KIT PART NUMBER (6)

	NBR	FKM
F100 XD040-063-100	06.021.00090	06.021.00135
F100 XD160-250-400	06.021.00096	06.021.00114

BOWL TIGHTENING TORQUE

screw up filter fill end

WARNING

- ⚠ Make sure that Personal Protective Equipment (PPE) is worn during installation and maintenance operation.

DISPOSAL OF FILTER ELEMENT

- ⚠ The used filter elements and the filter parts dirty of oil are classified as "Dangerous waste material": they must be disposed according to the local laws by authorized Companies.

INSTALLATION

- ⚠ 1. The IN and OUT ports must be connected to the hoses in the correct flow direction, an arrow shows on the filter head (1).
- 2. The filter housing should be preferably mounted with the bowl (5) downward.
- 3. Secure to the frame the filter head (1) using the threaded fixing holes (3).
- 4. Verify that no tension is present on the filter after mounting.
- 5. Enough space must be available for filter element replacement.
- 6. The visual clogging indicator must be in an easily viewable position.
- 7. When an electrical indicator is used, make sure that it is properly wired.
- ⚠ 8. Never run the system with no filter element fitted.
- 9. Keep in stock a spare FILTREC filter element for timely replacement when required.

OPERATION

- ⚠ 1. The filter must work within the operating conditions of pressure, temperature and compatibility given in the first page of this data sheet.
- 2. The filter element must be replaced as soon as the clogging indicator signals at working temperature (in cold start conditions, oil temperature lower than 30°C, a false alarm can be given due to oil viscosity).
- 3. If no clogging indicator is mounted, replace the element according to the system manufacturer's recommendations.

MAINTENANCE

- ⚠ 1. Make sure that the system is switched off and there is no residual pressure in the filter.
- 2. Unscrew the bowl (5) by turning it anti-clockwise and remove it.
- 3. Remove the dirty element (4).
- 4. Fit a new FILTREC element (4), verifying the part number, particularly concerning the micron rating; open its plastic protection on the open end side and insert it onto the spigot in the filter head, then remove completely the plastic protection.
- 5. Clean carefully the bowl; check the O-rings (6) conditions and replace if necessary.
- 6. Lubricate the bowl's thread (5) and screw it by hand in the filter head (1) by turning it clockwise.
- 7. Screw in the bowl to stop.
- ⚠ 8. The used filter elements cannot be cleaned and re-used.