



FUVD040 SERIES

Oil vacuum dehydrator and filtration unit

Remove free, emulsified, dissolved water and particulate from hydraulic and high viscosity lubricating oils



TECHNICAL SPECIFICATION

MAIN:	Flow Rate: 40 l/min Oil tank capacity: 150 l Water tank capacity: 25 l Operating temperature: 50-60 °C Fluid viscosity range: 32-460 cSt Final water content: <100 ppm Dehydration speed: 3.75 l/h (oil ISO VG 46)
ELECTRIC:	Voltage: 400 V Frequency: 50 Hz Power consumption: 14.5 kW Heater capacity: 7 kW
FRAME:	Dimensions L, W, H [mm]: 1411x916x1882 Dry Weight: 650 kg Inlet connections: 1" 1/2 Outlet connections: 3/4" Op. vacuum pressure: -0.65 bar / -0.85 bar
MATERIALS:	Base frame: Painted steel Vacuum chamber: Stainless steel Hydraulic seals: NBR
FLUID COMPATIBILITY:	Full with HH-HL-HM-HV HETG-HEES (acc. to ISO 6743/4). For use with other fluid please contact Filtrec Customer Service (info@filtrec.it).

The unit is supplied complete with an Instruction and Maintenance Manual available on our website www.filtrec.com in the "Hydraulic Filter" section. The unit can be used by authorized operators who have read and understood all of its contents.

The FUVD040 filtration unit is certified **CE**

For more information:

WEB: FLTR.com.au PHONE: (+61) 1300 62 4020 EMAIL: info@FLTR.com.au



IMPORTANCE OF MEASUREMENT

Water is a common contaminant in hydraulic systems. It can originate from several sources, such as: worn gaskets, reservoir covers, access panels, tank openings, breathers, condensation on inner surfaces, leaky heat exchangers or coolers, or other process issues. It can exist in hydraulic fluids and lubricants as dissolved or free water (emulsified). Each fluid has its own saturation point, beyond which the excess water can be present as a separate bulk water phase or as an emulsion.

The presence of water in hydraulic systems has significant implications. It promotes corrosion and wear of system components, leading to reduced component life and increased service costs. Water also affects the properties of the fluid, causing oxidation, acid formation, additive precipitation, and viscosity alteration. Consequently, the lubrication quality, load-carrying characteristics, and power transfer characteristics (compressibility) of the fluid are compromised. These effects can result in system malfunctions and increased costs for fluid disposal and procurement.

An effective way to mitigate water-related issues is through vacuum dehydration. By removing water from the system at minimum cost, vacuum dehydration ensures optimal performance. The amount of water a fluid can hold tightly depends on the fluid type, the temperature, and the pressure. A saturation curve illustrates the relationship between the saturation point and temperature (see Figure 1).

For instance, consider a system operating at temperature T_1 with an initial water content above the saturation curve (point A in Figure 1). Devices such as coalescers and centrifuges can only remove free water, reducing the water content to point B on the saturation curve. However, during system shutdown and a drop to ambient temperature T_2 , free water reappears (point C in Figure 1), nullifying the prior water removal efforts. With Filtrec's Vacuum Dehydration, the water content achieved is very low (point D in Figure 1), remaining below the saturation curve even after a temperature drop (point E in Figure 1). This prevents the formation of free water, which can cause serious damage to the system.

OPERATING PRINCIPLE

Contaminated oil is introduced into a mobile Vacuum Dehydration System. It then undergoes a filtration cycle using the suction line filter. The oil enters the vacuum chamber (shown as 1 in Figure 2) and passes through specially designed dispersal nozzles that increase the surface area of the oil exposed to the vacuum. Simultaneously, a secondary circuit (shown as 2 in Figure 2) continuously heats the oil until it reaches the dehydration temperature of $60\text{ }^{\circ}\text{C}$. This allows the water in the oil to evaporate easily and be conveyed into the condenser. The steam condenses back into water and drains into the condensation tank (shown as 3 in Figure 2). The dehydrated oil then flows to the bottom of the vacuum chamber and is discharged by the draining pump.

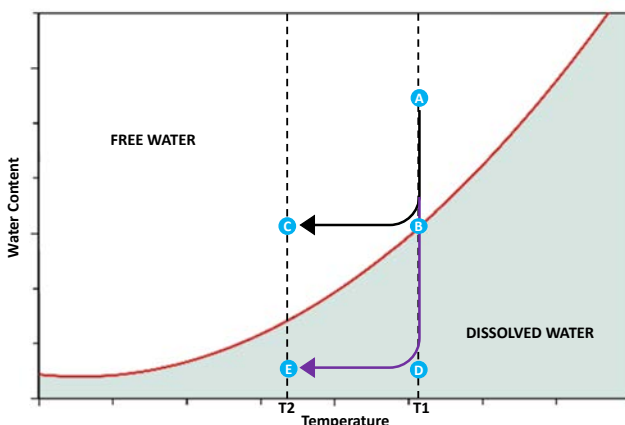

Figure 1

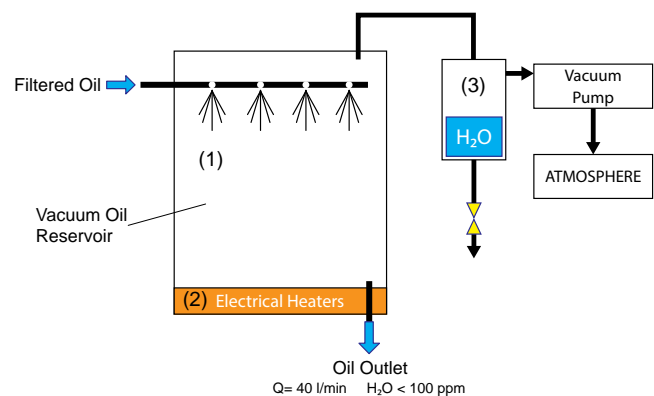

Figure 2

CAUTION

The air expelled by the vacuum pump may contain not only water but also elements from the operating fluid and any gases it contained. Make sure to connect the air outlet of the vacuum pump to a flexible hose for proper discharge in an open-air environment.

For more information:

WEB: FLTR.com.au PHONE: (+61) 1300 62 4020 EMAIL: info@FLTR.com.au

OVERALL DIMENSIONS

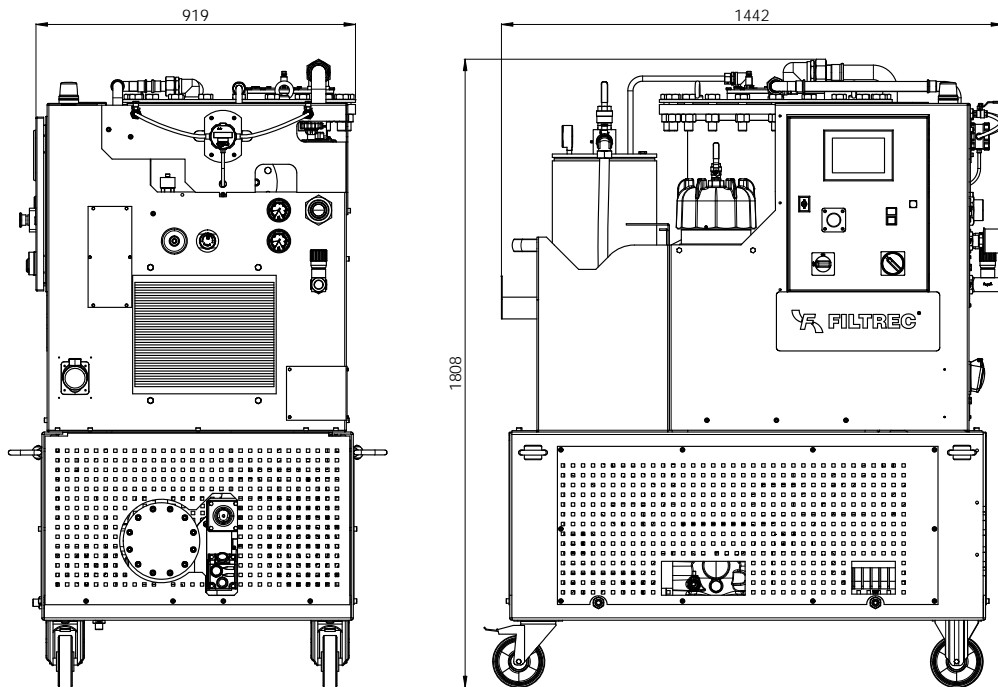

HYDRAULIC DIAGRAM

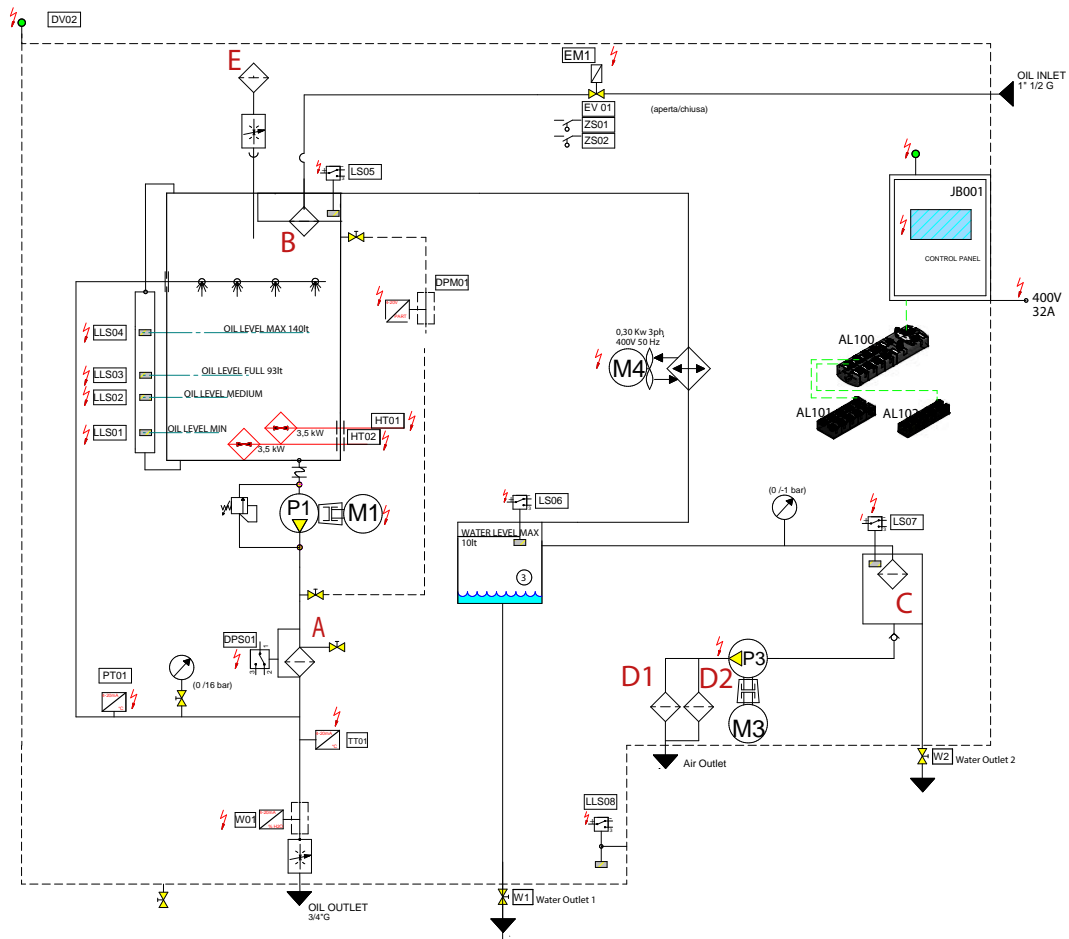

For more information:
 WEB: FLTR.com.au PHONE: (+61) 1300 62 4020 EMAIL: info@FLTR.com.au

ORDERING INFORMATION

FUVD40

1.	2.	3.	4.	5.	6.	7.	8.
FUVD	040	T	0	4	B	S	C
1. FILTER UNIT SERIES	FUVD						
2. MODEL	040	flow rate 40 l/min					
3. ELECTRIC MOTOR + SUPPLY SPECS	T	three phase electric motor, 230/400V 50-60Hz, 14.5 kW					
4. PUMP TYPE	0	standard system					
5. FILTER / ELEMENT SIZE	4	standard filter/element set U564T25B3					
6. SEALS	B	NBR					
7. VERSION	S	standard frame version					
8. OPTION	C	with contamination monitor FMSC01S0 (standard option)					
	0	without contamination monitor FMSC01S0					

ORDERING INFORMATION

MAIN FILTER ELEMENT

1.	2.	3.	4.	5.	6.
U5	64	G03	B	0	/007
1. FILTER ELEMENT SERIES	U5				
2. FILTER SIZE	64				
3. FILTER MEDIA	G01	glassfiber $\beta_{4\mu\text{m(c)}} > 1.000$			
	G03	glassfiber $\beta_{5\mu\text{m(c)}} > 1.000$			
	G06	glassfiber $\beta_{7\mu\text{m(c)}} > 1.000$			
	G10	glassfiber $\beta_{12\mu\text{m(c)}} > 1.000$			
	G15	glassfiber $\beta_{17\mu\text{m(c)}} > 1.000$			
	G25	glassfiber $\beta_{22\mu\text{m(c)}} > 1.000$			
	G40	glassfiber $\beta_{35\mu\text{m(c)}} > 1.000$			
	T25	wire mesh 25 μm			
4. SEALS	B	NBR			
5. BYPASS VALVE	0	no bypass			
	3	3 bar			
inbuilt into the filter element					
6. ELEMENT SUFFIX	/007	Improved compatibility for high water content fluid Not applicable to T25 media option			

ORDERING INFORMATION SPARE FILTER ELEMENTS FOR MAINTENANCE

The elements must be changed as specified in the Operating Manual.

FILTER ELEMENT	REFERENCE*	DESCRIPTION
U564...	A	MAIN FILTER ELEMENT
WT1628	B	SUCTION ELEMENT
WT2249	C	DEMISTER
WX663	D1, D2	OIL SEPARATOR
B120C10	E	AIR BREATHER ELEMENT

* See the reference numbers in the hydraulic diagram

KEY FEATURES

- 1 Compact and Portable**
The Filtrec's Vacuum Dehydrator is designed to be compact and portable, making it easy to load and unload from a commercial cargo van.
- 2 Low Power Consumption**
The Filtrec's Vacuum Dehydrator consumes less than 16kW, making it suitable for use in any industrial application.
- 3 Status Indicator Light**
The Filtrec's Vacuum Dehydrator is equipped with a status indicator light that shows the unit's operating status. The light is green when the unit is operating normally, yellow when there is a warning, and red when there is an alarm.
- 4 LED Strips**
The Filtrec's Vacuum Dehydrator also features colored LED strips that provide visibility in any environment.

USER TIPS

By default, the filtration unit series FUVD040 comes with a U564T25B3 filter element already installed. For higher filtration efficiencies, other filter elements can be selected from the table "ORDERING INFORMATION MAIN FILTER ELEMENT".

It is important to note that filtration unit series FUVD040 should always be used with a filter element to protect the dispersal nozzles. Without a filter element, the nozzles can be damaged by contaminants in the oil.

The filter element must be replaced when:

1. the target cleanliness class is reached; more filter elements could be necessary to reach it, depending on the oil volume to be cleaned and from the initial contamination level
2. the clogging indicator shows
3. a different filter media is required. We recommend a fine filtration

For more information:

WEB: FLTR.com.au PHONE: (+61) 1300 62 4020 EMAIL: info@FLTR.com.au