



E SERIES

Electrical differential clogging indicators



PRESSURE:	Max operating up to 420 bar
CONNECTION:	M20x1,5
MATERIALS:	Body: Brass Cover and connector: PA66 + G.F. Seal: NBR standard FKM on request
SETTINGS ΔP :	1,3 bar \pm 10% 2,7 bar \pm 10% 5,0 bar \pm 10% 8,0 bar \pm 10%
ELECTRICAL SPECS.:	Contact configuration SPDT
CONNECTOR TYPE:	according to DIN 43650 with cable gland PG09/PG11
DEGREE OF PROTECTION:	IP65 according to EN60529
OPERATING TEMPERATURE:	-30°C - +80°C
FLUID COMPATIBILITY:	Full with HH-HL-HM-HV-HETG-HEES-HFA HFB-HFC (acc. to ISO 6743/4). For use with other fluid please contact Filtrtec Customer Service (info@filtrtec.it).

For more information:

WEB: FLTR.com.au PHONE: (+61) 1300 62 4020 EMAIL: info@FLTR.com.au

OVERALL DIMENSIONS

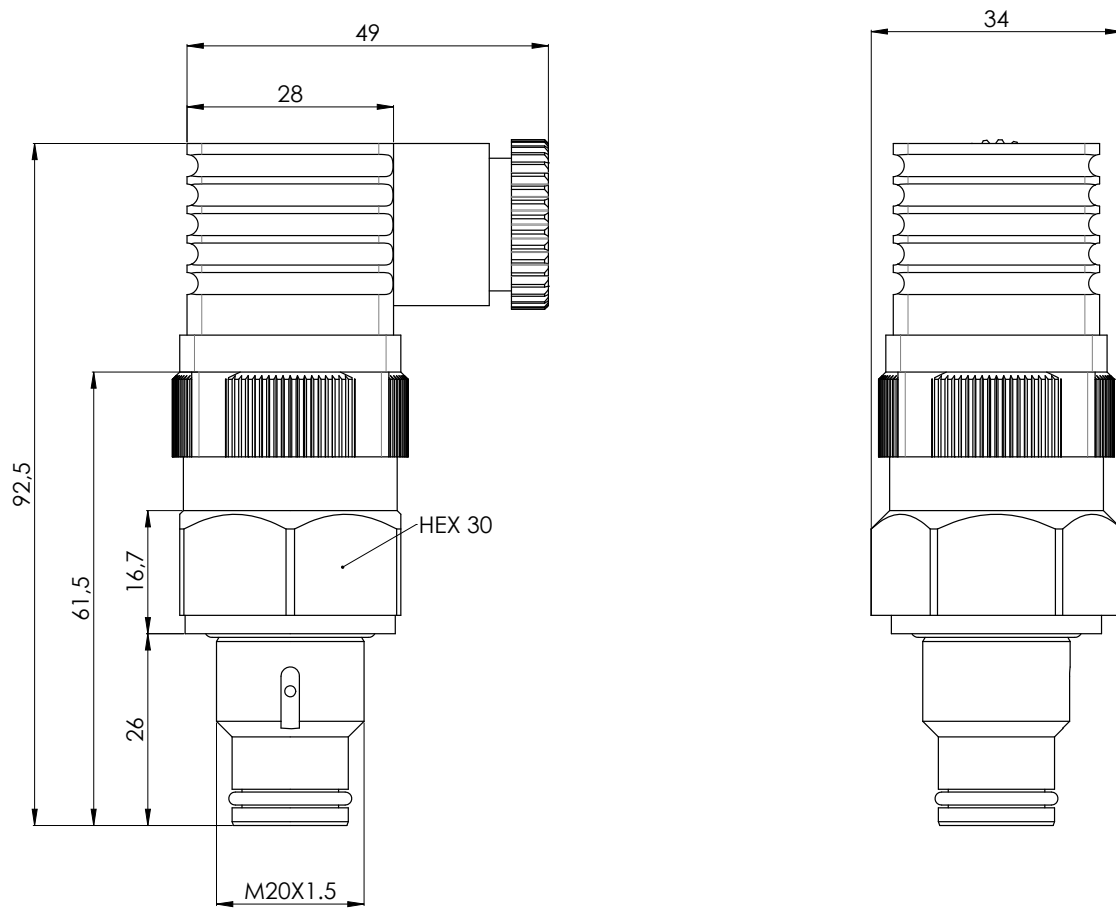

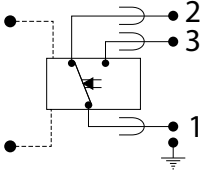
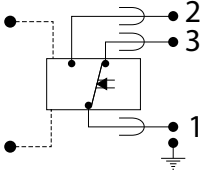

Weight: 173,6 gr

MECHANICAL CONDITION

ΔP CONDITION	ELECTRIC SYMBOL
$P+ - P- < \Delta P_{set}$	
$P+ - P- \geq \Delta P_{set}$	

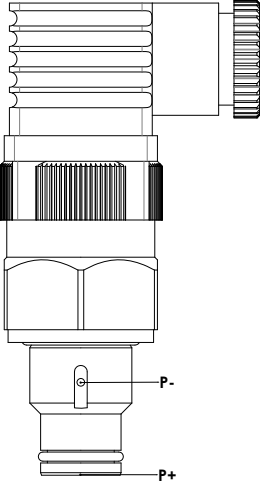
ORDERING INFORMATION / DETAILS

ORDER CODE	MODEL	SEALS	VIEW	SETTING	ELECTRICAL SPECS.
04.006.00129 04.006.00130	E02 EF2	NBR FKM		2,7 bar	<ul style="list-style-type: none"> • Connector DIN 43650 • Max AC voltage: 250Vac • Max current: 5A resistive 1A inductive • Max DC voltage: 30Vdc • Max current: 4A resistive 3A inductive • Protection: IP65 EN60529
04.006.00131 04.006.00132	E05 EF5	NBR FKM		5,0 bar	
04.006.00136 04.006.00137	E08 EF8	NBR FKM		8,0 bar	

 50 / 90 Nm - See hydraulic filter catalogues

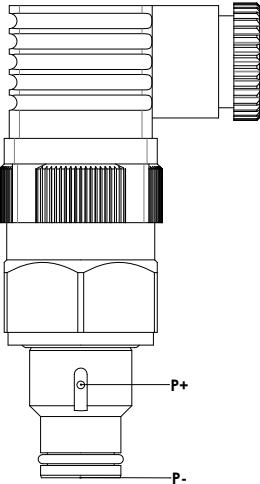
ORDER CODE	MODEL	SEALS	VIEW	SETTING	ELECTRICAL SPECS.
04.006.00664 04.006.00665	EX1 EY1	NBR FKM		1,3 bar	<ul style="list-style-type: none"> • Connector DIN 43650 • Max AC voltage: 250Vac • Max current: 5A resistive 1A inductive • Max DC voltage: 30Vdc • Max current: 4A resistive 3A inductive • Protection: IP65 EN60529
04.006.00520 04.006.00521	EX2 EY2	NBR FKM		2,7 bar	
04.006.00133 04.006.00134	EX5 EY5	NBR FKM		5,0 bar	
04.006.00138 04.006.00139	EX8 EY8	NBR FKM		8,0 bar	

 50 / 90 Nm - See hydraulic filter catalogues

For more information:

WEB: FLTR.com.au PHONE: (+61) 1300 62 4020 EMAIL: info@FLTR.com.au

OPTIONAL VERSION

The LC24 connector, supplied separately, can replace the standard black connector of the "E" indicator. Powered with 24Vdc, it gives a visual indication of the filter element conditions: normally the GREEN LED is on, the RED LED switch on when the element is clogged.

ORDER CODE	MODEL	VIEW	ELECTRICAL SPECS.
04.006.00146	LC24		

INSTRUCTIONS FOR REPLACING THE std CONNECTOR WITH THE LC24 CONNECTOR

1. UNSCREW THE SCREW



2. DISCONNECT THE STANDARD CONNECTOR



3. ATTACH THE LC24 CONNECTOR





4. TIGHTEN THE SCREW



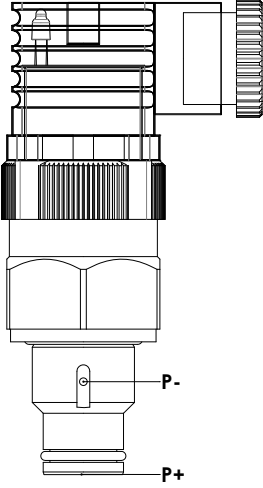

VERSION WITH INTEGRATED LED CONNECTOR

Subject to MOQ our differential indicators type E... can be supplied in special versions with INTEGRATED LC24 connector.

ORDERING INFORMATION / DETAILS

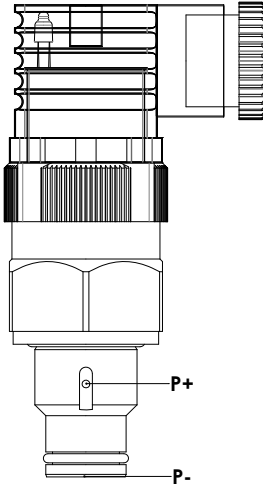
ORDER CODE	MODEL	SEALS	VIEW	SETTING	ELECTRICAL SPECS.
04.006.00522 04.006.00523	E02L EF2L	NBR FKM		2,7 bar	<ul style="list-style-type: none"> • Connector DIN 43650 • Max DC voltage: 24Vdc • Max current: 4A resistive 3A inductive • Protection: IP65 EN60529
04.006.00169 04.006.00524	E05L EF5L	NBR FKM		5,0 bar	
04.006.00177 04.006.00525	E08L EF8L	NBR FKM		8,0 bar	
 50 / 90 Nm - See hydraulic filter catalogues					

ORDER CODE	MODEL	SEALS	VIEW	SETTING	ELECTRICAL SPECS.
04.006.00526 04.006.00527	EX2L EY2L	NBR FKM		2,7 bar	<ul style="list-style-type: none"> • Connector DIN 43650 • Max DC voltage: 24Vdc • Max current: 4A resistive 3A inductive • Protection: IP65 EN60529
04.006.00528 04.006.00529	EX5L EY5L	NBR FKM		5,0 bar	
04.006.00530 04.006.00531	EX8L EY8L	NBR FKM		8,0 bar	
 50 / 90 Nm - See hydraulic filter catalogues					

For more information:

WEB: FLTR.com.au PHONE: (+61) 1300 62 4020 EMAIL: info@FLTR.com.au

INDICATOR SEAT

E0.../EF.../E0...L/EF...L

EX.../EY.../EX...L/EY...L

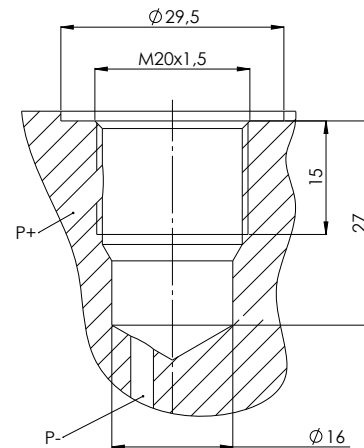
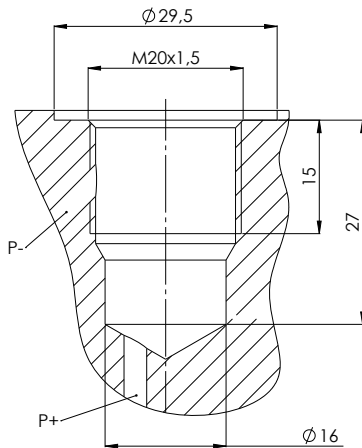

Dimensions and tolerances available on request

USER INFORMATION

The Differential indicator measures the Δp between upstream and downstream of the filter element, i.e. it is the ideal indicator for the in line applications.

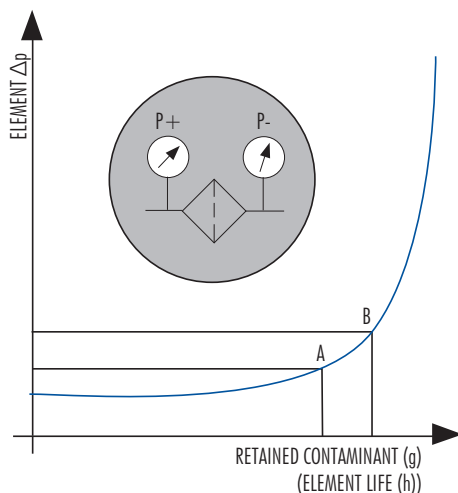

The **Pressure Drop** (Δp = differential pressure) through the filter increases during the system operation due to the contaminant retained by the filter element.

The filter element must be replaced when the indicator shows an alarm and before the Δp reaches the by-pass set value (i.e. the set value A of the clogging indicator must always be lower than the set value B of the by-pass value).

WARNING: in **cold start** conditions a false alarm can be caused by higher oil viscosity due to low temperature; the indicator alarm must be considered at normal working temperature only.

OPTIONAL VERSION

Subject to MOQ our differential indicators type E... can be supplied in special versions like ATEX or with different connectors.

Contact our Customer Service for further information.

For more information:

WEB: FLTR.com.au PHONE: (+61) 1300 62 4020 EMAIL: info@FLTR.com.au

APPLICATION

The following table shows the type of indicator available according to the filter used.

APPLICATION	FILTER CODE	INDICATOR MODEL						
		E02/EF2 E02L/EF2L	E05/EF5 E05L/EF5L	E08/EF8 E08L/EF8L	EX1/EY1	EX2/EY2 EX2L/EY2L	EX5/EY5 EX5L/EY5L	EX8/EY8 EX8L/EY8L
IN LINE HIGH PRESSURE	F100	X	X	X				
	F280		X	X				
	F420		X	X				
	FD3						X	X
	FDM						X	X
	FH100	X	X	X				
	FH250		X	X				
	FH320		X	X				
	FH420		X	X				
	FML320		X	X				
IN LINE MEDIUM PRESSURE	FLR				X	X	X	X
	FLRD				X	X	X	X
	F040	X	X	X				
RETURN	FCR7F2x	X						
	FCR7F3x	X						
SPIN-ON	FAH-A14x	X						
	FA5					X		
	FA4					X		