



## FA2 SERIES

Tank-top, spin-on type filters

Return line filters with spin-on cartridge for operating pressure up to 12 bar, flow rate up to 300 l/min.

Bypass valve inbuilt in the filter element, indicator port is a standard option to fit a visual or electrical indicator.



<b>HOUSING</b>	tested according to NFPA T3.10.17, ISO12829, ISO3968
<b>PRESSURE:</b>	Max operating: 12 bar Burst: 20 bar
<b>CONNECTIONS:</b>	G 3/4" ÷ G 1 1/2"
<b>MATERIALS:</b>	Head: aluminium alloy Bowl: painted steel Seal: NBR
<b>BYPASS VALVE:</b>	1,7 bar
<b>ELEMENT</b>	tested according to ISO 11170, 2941, 2942, 2943, 3724, 3968, 16889, 16908, 23181
<b>FILTER MEDIA:</b>	Paper: C10 - C25 Inorganic microfiber: G10 - G25 Wire mesh: T60
<b>COLLAPSE PRESSURE:</b>	5 bar
<b>TEMPERATURE RANGE:</b>	from -30 °C to +100 °C
<b>FLUID COMPATIBILITY:</b>	Full with HH-HL-HM-HV HETG-HEES (acc. to ISO 6743/4). For use with other fluid please contact Filtrec Customer Service (info@filtrec.it).

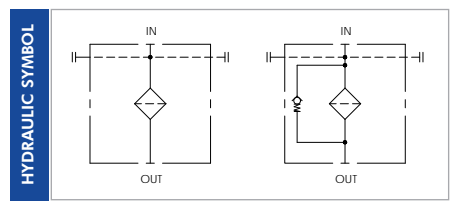

For more information:

WEB: FLTR.com.au PHONE: (+61) 1300 62 4020 EMAIL: info@FLTR.com.au

## OVERALL DIMENSIONS

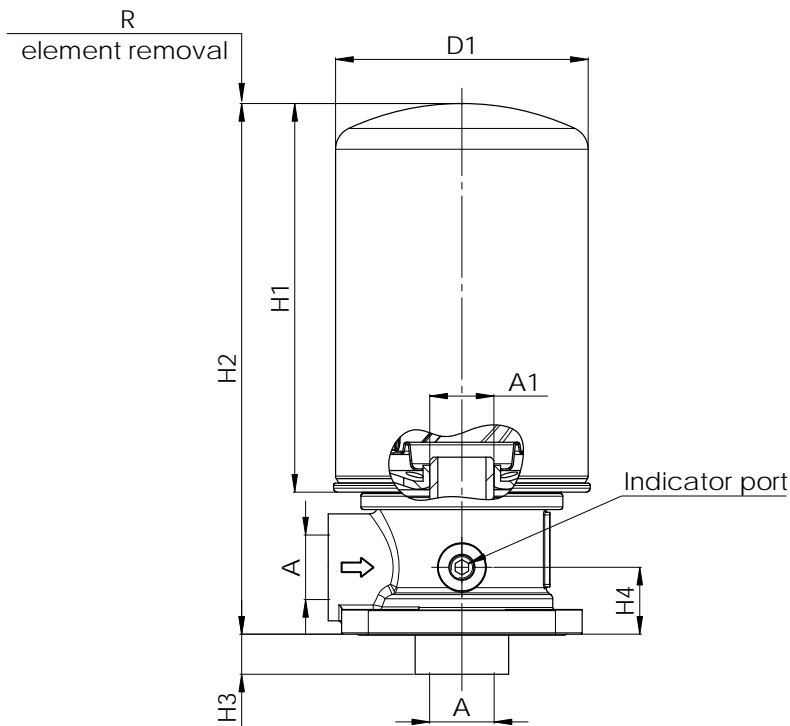
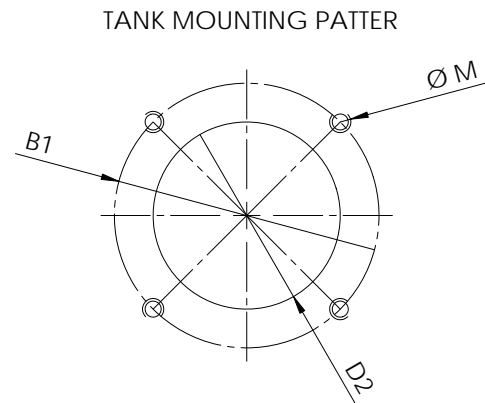
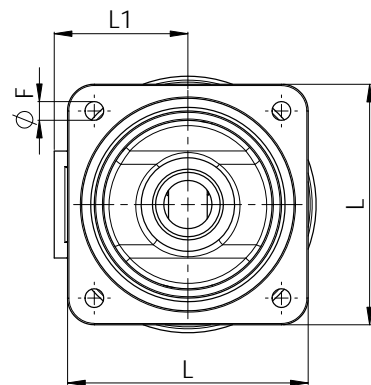

## NOMINAL SIZE

CODE	A	B1	D1	D2	Ø F	H1	H2	H3	H4	L	L1	Ø M	R	WEIGHT ELEMENT	A1
FA2-10	G 3/4"	99	96	40÷45	7	148	200	15	25	90	50	M6	20	1,3 Kg	A-2-10
FA2-11						213	265							1,6 Kg	A-2-11
FA2-20	G 1 1/2"	141	128	65÷70	9	182	255	20	36	122	70	M8	40	2,1 Kg	A-2-20
FA2-21						228	300							2,3 Kg	A-2-21

For more information:

WEB: FLTR.com.au PHONE: (+61) 1300 62 4020 EMAIL: info@FLTR.com.au

## ORDERING INFORMATION

	1.	2.	3.	4.	5.	6.	7.	8.
	<b>F</b>	<b>A2</b>	<b>21</b>	<b>C10</b>	<b>BM</b>	<b>B</b>	<b>B7</b>	<b>000</b>
SPARE ELEMENT		<b>A2</b>	<b>21</b>	<b>C10</b>	<b>BM</b>			

1. FILTER SERIES	F		
2. FILTER ELEMENT SERIES	A2		
3. FILTER SIZE	10-11		
	20-21		
4. FILTER MEDIA	000	no element	
	C10	paper $\beta_{10\mu m(c)} > 2$	
	C25	paper $\beta_{25\mu m(c)} > 2$	
	G10	glassfiber $\beta_{12\mu m(c)} > 1.000$	
	G25	glassfiber $\beta_{22\mu m(c)} > 1.000$	
	T60	wire mesh 60 mm	
5. ELEMENT FEATURES	0	no element	
	BM	bypass 1,7 bar and antidrain membrane	
6. SEALS	B	NBR	
7. CONNECTIONS	B4	G 3/4"	for sizes 10-11
	B7	G 1 1/2"	for sizes 20-21
8. COMPULSORY FIELD	000	Filtrec standard	

## ACCESSORIES

The accessories must be ordered separately

INDICATOR  * Available also with LC24=Led connector (see clogging indicators catalogue)	MPB	pressure gauge 0÷10 bar
	*PDB	pressure switch 1,3 bar SPDT
	MPA	pressure / vacuum gauge -1 ÷ 5 bar
	LC24	LED connector for pressure switch

For more information:

WEB: [FLTR.com.au](http://FLTR.com.au) PHONE: (+61) 1300 62 4020 EMAIL: [info@FLTR.com.au](mailto:info@FLTR.com.au)

## PRESSURE DROP ( $\Delta p$ ) INFORMATION FOR FILTER SIZING

The total Delta P through a filter assembly is given from Housing  $\Delta p$  + Element  $\Delta p$ . This ideally should not exceed 0,5 bar and should never exceed 1/3 of the set value of the by-pass valve. N.B. All the reported data have been obtained at our laboratory, according to specification ISO3968 with mineral oil having 32 cSt viscosity and density 0,875 Kg/dm<sup>3</sup>.

### HOUSING PRESSURE DROP

The housing  $\Delta p$  is given by the curve of the considered model and port, in correspondence of the flow rate value.

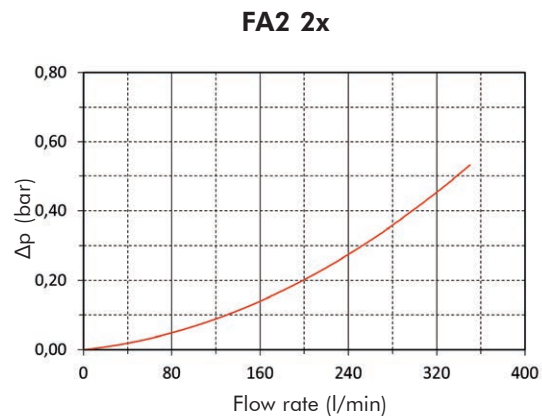
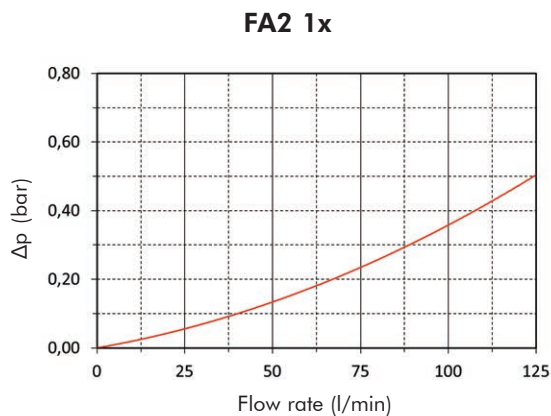

### ELEMENT PRESSURE DROP

The element  $\Delta p$  (bar) is given by the flow rate (l/min) multiplied by the factor in the table here below corresponding to the selected media and divided by 1000. If the oil has a viscosity  $V_x$  different than 32 cSt a corrective factor  $V_x/32$  must be applied.

Example: 125 l/min with A220C10BM and oil viscosity 46 cSt  $> 125 \times 0,67/1000 \times 46/32 = 0,12$  bar

	<b>C10BM</b>	<b>C25BM</b>	<b>G10BM</b>	<b>G25BM</b>	<b>T60BM</b>
<b>A210</b>	1,90	1,70	3,60	2,80	0,90
<b>A211</b>	1,60	0,90	3,40	1,60	0,50
<b>A220</b>	0,67	0,57	2,33	1,23	0,27
<b>A221</b>	0,60	0,47	2,00	1,00	0,23

### EXAMPLE OF TOTAL $\Delta p$ CALCULATION

FA220C10BMBB7000 with 125 l/min and oil 46 cSt:

Housing  $\Delta p$  0,1 bar + element  $\Delta p$  0,12 bar ( $125 \times 0,67/1000 \times 46/32$ ) = total assembly  $\Delta p$  0,22 bar

## BYPASS VALVE PRESSURE DROP

The bypass valve  $\Delta p$  is given by the curve of the considered model and setting, in correspondence of the flow rate value.

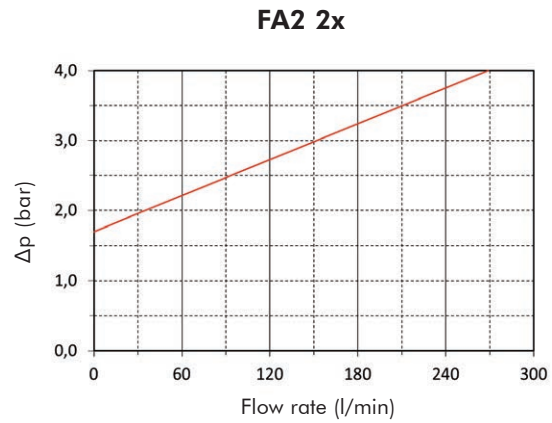
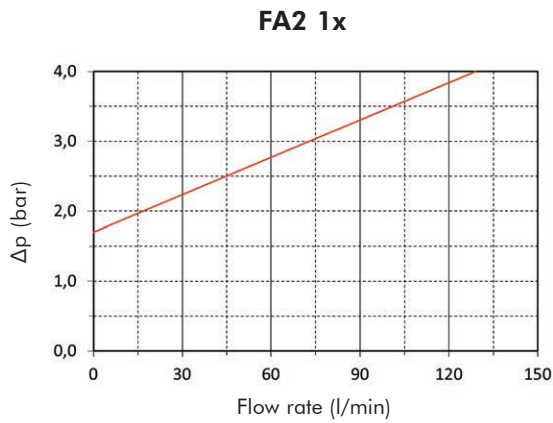

N.B. All the reported data have been obtained at our laboratory, according to specification ISO3968 with mineral oil having 32 cSt viscosity and density 0,875 Kg/dm<sup>3</sup>.

For more information:

WEB: [FLTR.com.au](http://FLTR.com.au) PHONE: (+61) 1300 62 4020 EMAIL: [info@FLTR.com.au](mailto:info@FLTR.com.au)

## USER TIPS



- 1 FILTER HEAD
- 2 INDICATOR PORT
- 3 FIXING HOLES
- 4 FILTER ELEMENT

## INSTALLATION

- ⚠ 1. Secure the filter head (1) on the tank lid through the fixing holes (3).
2. Connect the hose to the IN port and verify that the OUT port is clear.
3. Verify that no tension is present on the filter after mounting.
4. Enough space must be available for filter element cartridge replacement.
5. The visual clogging indicator must be in a easily viewable position.
6. When a electrical indicator is used, make sure that it is properly wired.
- ⚠ 7. Never run the system with no filter element fitted.
8. Keep in stock a spare FILTREC filter element for timely replacement when required.

## OPERATION

- ⚠ 1. The filter must work within the operating conditions of pressure, temperature and compatibility given in the first page of this data sheet.
2. The filter element must be replaced as soon as the clogging indicator signals at working temperature (in cold start conditions, oil temperature lower than 30°C, a false alarm can be given due to oil viscosity).
3. If no clogging indicator is mounted, replace the element according to the system manufacturer's recommendations.

### CARTRIDGE TIGHTENING TORQUE

All models	3/4 turn
------------	----------

### INDICATOR TIGHTENING TORQUE

Pressure gauge/switch	10 Nm
-----------------------	-------

## WARNING

- ⚠ Make sure that Personal Protective Equipment (PPE) is worn during installation and maintenance operation.

## DISPOSAL OF FILTER ELEMENT

- ⚠ The used filter elements and the filter parts dirty of oil are classified as "Dangerous waste material": they must be disposed according to the local laws by authorized Companies.

## MAINTENANCE

- ⚠ 1. Make sure that the system is switched off and there is no residual pressure in the filter.
2. Unscrew the filter cartridge (4) by turning it anti-clockwise and remove it.
3. Fit a new FILTREC cartridge element (4), verifying the part number, particularly concerning the micron rating.
4. Ensure that the head mounting face is clean.
- ⚠ 5. Lubricate the gasket of the replacement cartridge and the thread prior to assembly.
7. Spin on the new cartridge until it reaches the mounting face and tighten for 3/4 turn.

For more information:

WEB: [FLTR.com.au](http://FLTR.com.au) PHONE: (+61) 1300 62 4020 EMAIL: [info@FLTR.com.au](mailto:info@FLTR.com.au)