



FA3 SERIES

Flange mounted with spin-on element



TECHNICAL SPECIFICATION

MATERIALS:	Canister: painted steel Flange and basket: zinc plated steel Gasket: NBR
FILTER MEDIA:	Cellulose (air filtration 3µm) Glassfiber (air filtration 1µm)
TEMPERATURE RANGE:	-30°C to +100°C
FLUID COMPATIBILITY:	Full with HH-HL-HM-HV HETG-HEES (acc. to ISO 6743/4). For use with other fluid please contact Filtrec Customer Service (info@filtrec.it).

HYDRAULIC SYMBOL

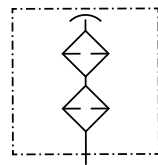

AIR BREATHING SIZING

Air Breathers play a crucial role as part of a hydraulic system's filtration mechanism. The amount of dust retained by an Air Breather depends on various factors, such as the average air dust concentration and the air flow passing through the breather in NI/min. The following table illustrates the typical average air dust concentrations found in real-life environments. Notably, these concentrations can vary significantly, thus impacting the service life of the Air Breather.

DUST CONCENTRATION (depends on application and environment)	$K_{op.cond}$
High level	7 ÷ 10
Medium level	3 ÷ 7
Low level	1 ÷ 3

Measuring the air flow poses a challenging task. Typically, this parameter can be estimated using the following equation:

$$Q_{air\ flow} = K_{op.cond} \times Q$$

Here, Q represents the flow rate of the hydraulic pump in l/min, and $K_{op.cond}$ is a multiplicative factor associated with the operating conditions. For instance, in ambient conditions with low dust concentration, $K_{op.cond}$ may range between 1 and 2, while in environments with high dust concentration, it could be in the range of 7 to 10. It is important to note that $K_{op.cond}$ is subject to substantial variability, which, in turn, introduces uncertainty in the service life of the Air Breather.



Filtrec's Air Breathers serve as a fundamental element in every hydraulic system.

It is essential to bear in mind that removing particles from a hydraulic system incurs significantly higher costs compared to excluding them in the first place.

Given this undeniable truth, it becomes evident that the advantages of utilizing our high-quality air breathers are substantial.

We highly recommend replacing the air breather with each service interval (or, at the very least, annually), matching the frequency of replacing the return fluid filters. Doing so ensures optimal performance and longevity of the hydraulic system.

OVERALL DIMENSIONS

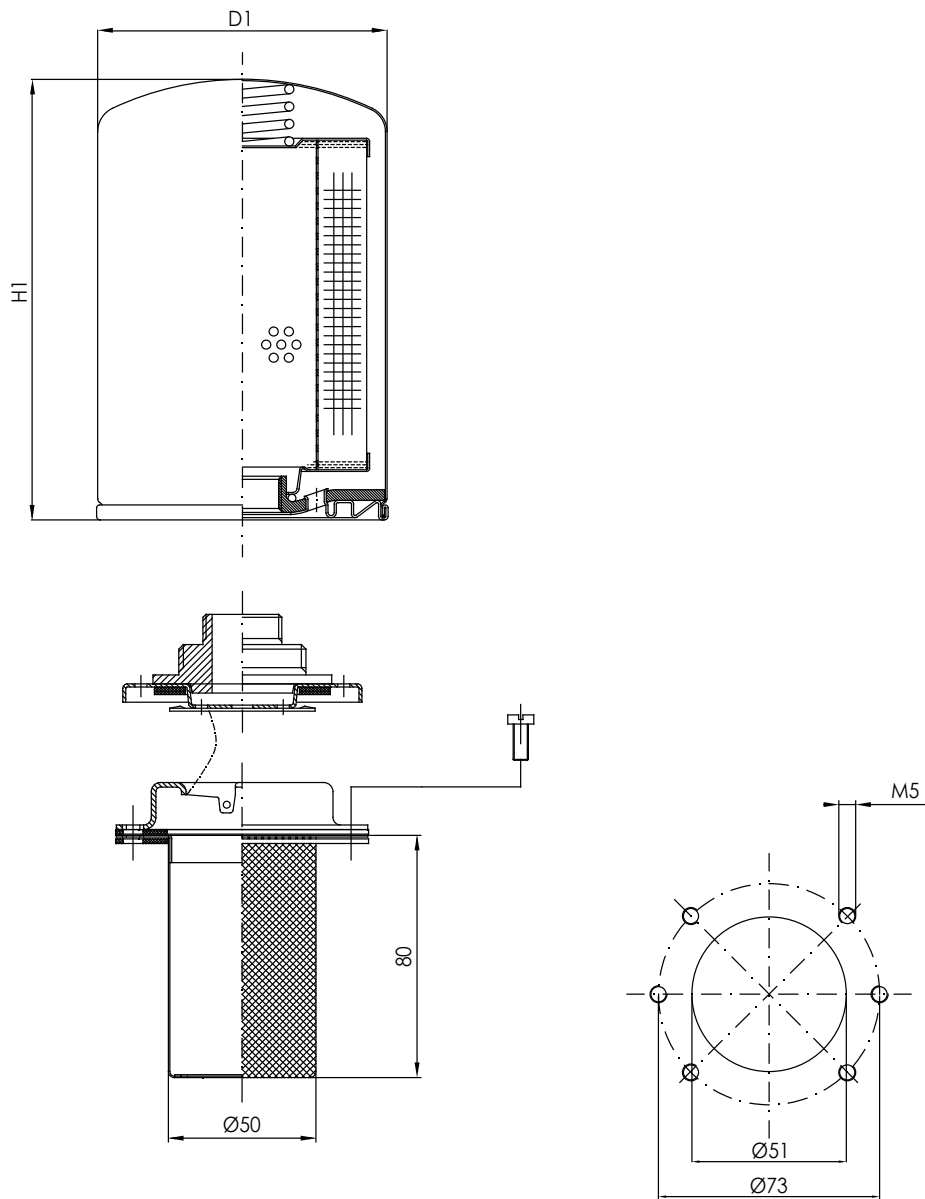

NOMINAL SIZE

CODE	D1	H1	G	AIR FLOW RATE NI/min Dp 0,015 barg		SPIN-ON ELEMENT
				C03	G01	
FA310	96	145	G 3/4"	550	530	A310
FA311		213				A311
FA320	129	180	G 1 1/4"	1415	1330	A320
FA321		228				A321

ORDERING INFORMATION

	1.	2.	3.
SPARE ELEMENT	FA3	10	C03
	A3	10	C03

1. SERIES	FA3	
2. FILTER SIZE	10-11	base assembly, with spin-on
	20-21	
3. FILTER MEDIA	C03	cellulose (air filtration 3 μ m)
	G01	glassfiber (air filtration 1 μ m)

ORDERING INFORMATION without spin-on

1.	2.
FA3	WE

1. SERIES	FA3	
2. FILTER SIZE	WE	base assembly, without spin-on

ACCESSORIES

The accessories must be ordered separately

06.016.00548	BS125 Spacer support
--------------	----------------------



**SPACER SUPPORT
BS125**

When the oil tank can be subjected to strong shocks or oscillations, the optional spacer support (BS125) prevents oil splashes from escaping and wetting the filter element.

USER TIPS



- 1 SPIN-ON
- 2 SCREWS
- 3 FLANGE
- 4 GASKET
- 5 BASKET
- 6 GASKET



WARNING

-  Make sure that Personal Protective Equipment (PPE) is worn during installation and maintenance operation.

DISPOSAL OF FILTER ELEMENT

-  The used filter elements and the filter parts dirty of oil are classified as "Dangerous waste material": they must be disposed according to the local laws by authorized Companies.

INSTALLATION

1. The air breather filters are mounted on the tank in a threaded seat (no burrs, sharp edges or dirt is admitted on the seat).
2. Put the first gasket (6) on the tank keeping the holes aligned.
3. Insert the basket (5) in the tank hole keeping the holes aligned.
4. Put the second gasket (4) between the basket and the flange (3).
5. Place the flange (3) on the second gasket keeping the holes aligned.
6. Secure the components to the tank with the screws (2).
7. Screw the spin-on (1) on the flange male thread (3) until it is locked.

MAINTENANCE

-  1. Before removing the spin-on (1), ensure that the system is switched off and there is no residual pressure in the system.
- 2. Unscrew the spin-on (1).
- 3. Screw the new spin-on following installation instruction.