



## FDD040 SERIES

Duplex low pressure filters  
 Sizes 040 to 400 according to DIN 24550

Inline filters for operating pressure up to 63 bar, flow rate up to 400 l/min.

Duplex construction for uninterrupted service. Change over valve on upstream side, ergonomic switch-over handle with safety lock and pressure compensation.



### HOUSING

tested according to NFPA T3.10.5.1, ISO 10771, ISO 3968

**PRESSURE:** max operating 63 bar sizes 040 to 100  
 max operating 32 bar sizes 160 to 400

**CONNECTIONS:** G 1"  
 G 1 1/2"

**MATERIALS:** Head: aluminium alloy  
 Bowl : aluminium alloy; painted  
 carbon steel for size FDD040XD400 only  
 Seals: NBR

**BYPASS VALVE:** 3,5 bar

### ELEMENT

tested according to ISO 11170, 2941, 2942, 2943, 3724, 3968, 16889, 16908, 23181

**FILTER MEDIA:** glassfiber G01 - G03 - G06 - G10 -G15  
 G25

**COLLAPSE PRESSURE:** 20 bar  
 210 bar

**TEMPERATURE RANGE:** -30°C +100°C

**FLUID COMPATIBILITY:** Full with HH-HL-HM-HV  
 HETG-HEES (acc. to ISO 6743/4).  
 For use with other fluid please  
 contact Filtrec Customer Service  
 (info@filtrec.it).

For more information:

WEB: FLTR.com.au PHONE: (+61) 1300 62 4020 EMAIL: info@FLTR.com.au

## OVERALL DIMENSIONS

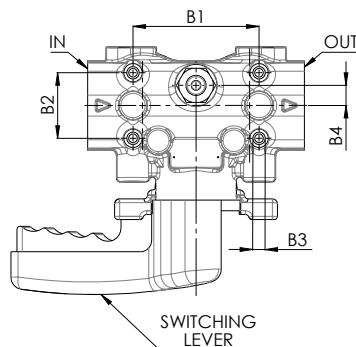
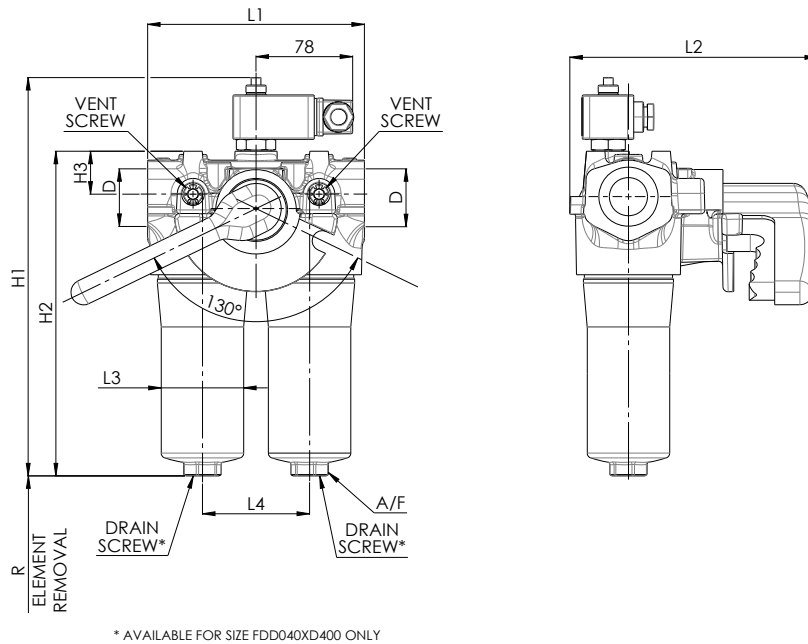

## NOMINAL SIZE

MODEL	B1	B2	B3	B4	D	L1	L2	L3	L4	H1	H2	H3	A/F	R	WEIGH
FDD040XD040										258	200				2,6 Kg
FDD040XD063	100	52	M8x15	16	G 1"	172	189	66	85	316	258	34	27	80	2,9 Kg
FDD040XD100										406	348				3,3 Kg
FDD040XD160										347	284				8,6 Kg
FDD040XD250	210	62	M10x20	19	G 1 1/2"	283	252	109	140	448	385	42	32	110	9,5 Kg
FDD040XD400										590	527				19,0 Kg

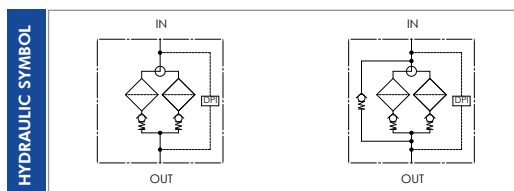

For more information:

WEB: [FLTR.com.au](http://FLTR.com.au) PHONE: (+61) 1300 62 4020 EMAIL: [info@FLTR.com.au](mailto:info@FLTR.com.au)

## ORDERING INFORMATION

	1.	2.	3.	4.	5.	6.	7.	8.	9.	10.	11.	12.
	<b>FDD040</b>	<b>XD</b>	<b>100</b>	<b>G10</b>	<b>A</b>	<b>B</b>	<b>B5</b>	<b>D</b>	<b>S</b>	<b>000</b>	<b>S</b>	<b>0</b>
SPARE ELEMENT		<b>XD</b>	<b>100</b>	<b>G10</b>	<b>A</b>							

1. FILTER SERIES	FDD040	
2. FILTER ELEMENT SERIES	XD	
3. FILTER SIZE	040-063-100	
	160-250-400	
4. FILTER MEDIA	000	no element
	G01	glassfiber $\beta_{4\mu m(c)} > 1.000$
	G03	glassfiber $\beta_{5\mu m(c)} > 1.000$
	G06	glassfiber $\beta_{7\mu m(c)} > 1.000$
	G10	glassfiber $\beta_{12\mu m(c)} > 1.000$
	G15	glassfiber $\beta_{17\mu m(c)} > 1.000$
	G25	glassfiber $\beta_{22\mu m(c)} > 1.000$
5. ELEMENT COLLAPSE	A	21 bar
	B	210 bar
6. SEALS	B	NBR
7. CONNECTIONS	B5	G 1" for sizes 040-063-100
	B7	G 1 1/2" for sizes 160-250-400
8. BYPASS VALVE	0	no by-pass
	D	3,5 bar
9. INDICATOR PORT OPTION	S	with metal plug
10. COMPULSORY FIELD	000	filtrec standard
11. CORROSION PROTECTION	S	standard
12. OPTION	0	no option

## ACCESSORIES

The accessories must be ordered separately

INDICATOR For indicators detail see service instructions	FG2	differential visual and electric 2,2 bar
	FG5	differential visual and electric 5 bar recommended for no bypass option
	FG8	differential visual and electric 8 bar

For more information:

WEB: [FLTR.com.au](http://FLTR.com.au) PHONE: (+61) 1300 62 4020 EMAIL: [info@FLTR.com.au](mailto:info@FLTR.com.au)

## PRESSURE DROP ( $\Delta p$ ) INFORMATION FOR FILTER SIZING

The total Delta P through a filter assembly is given from Housing  $\Delta p$  + Element  $\Delta p$ .

This ideally should not exceed 1,0 bar and should never exceed 1/3 of the set value of the by-pass valve. N.B. All the reported data have been obtained at our laboratory, according to specification ISO3968 with mineral oil having 32 cSt viscosity and density 0,875 Kg/dm<sup>3</sup>.

### HOUSING PRESSURE DROP

The housing  $\Delta p$  is given by the curve of the considered model and port, in correspondence of the flow rate value.

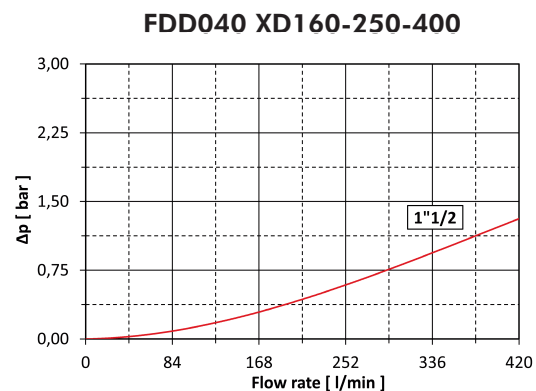
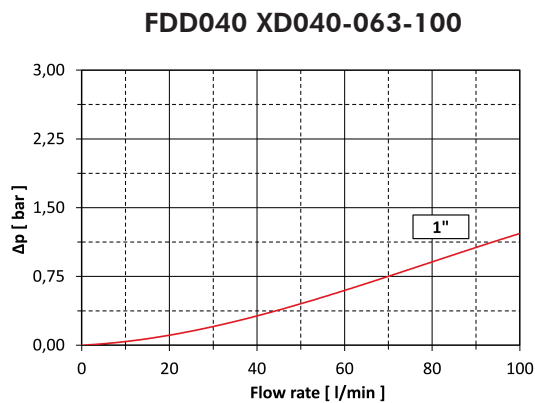

### ELEMENT PRESSURE DROP (filter elements 20 bar collapse)

The element  $\Delta p$  (bar) is given by the flow rate (l/min) multiplied by the factor in the table here below corresponding to the selected media and divided by 1000.

If the oil has a viscosity  $V_x$  different than 32 cSt a corrective factor  $V_x/32$  must be applied.

Example: 40 l/min with XD100G10A and oil viscosity 46 cSt:  $40 \times 3,6/1000 \times 46/32 = 0,21$  bar.

	G01A	G03A	G06A	G10A	G15A	G25A
<b>XD040</b>	22	15,4	13,5	7,88	6,75	5,63
<b>XD063</b>	16,15	11,31	9	5,54	4,85	4,15
<b>XD100</b>	12	8,4	5,85	3,6	3,15	2,7
<b>XD160</b>	7,81	5,47	4,47	2,63	1,84	1,49
<b>XD250</b>	5,2	3,64	2,61	1,68	0,91	0,86
<b>XD400</b>	3,25	2,28	1,52	1,12	0,64	0,57

### EXAMPLE OF TOTAL $\Delta p$ CALCULATION

FDD040XD100G10ABB5DS000S0 with 40 l/min and oil 46 cSt:

Housing  $\Delta p$  0,38 bar + element  $\Delta p$  0,21 bar ( $40 \times 3,6/1000 \times 46/32$ ) = total assembly  $\Delta p$  0,59 bar.

## ELEMENT PRESSURE DROP (filter elements 210 bar collapse)

The element  $\Delta p$  (bar) is given by the flow rate (l/min) multiplied by the factor in the table here below corresponding to the selected media and divided by 1000.

If the oil has a viscosity  $V_x$  different than 32 cSt a corrective factor  $V_x/32$  must be applied.

Example: 40 l/min with XD100G10B and oil viscosity 46 cSt:  $40 \times 6,75/1000 \times 46/32 = 0,39$  bar.

	G01B	G03B	G06B	G10B	G15B	G25B
<b>XD040</b>	34,97	24,48	22,5	14,63	12,38	10,13
<b>XD063</b>	29,23	20,46	16,62	10,38	8,65	6,92
<b>XD100</b>	19	13,3	10,35	6,75	5,85	4,95
<b>XD160</b>	8,13	5,69	4,74	3,37	2,81	2,25
<b>XD250</b>	5,4	3,78	3,06	2,52	2,16	1,8
<b>XD400</b>	3,38	2,36	1,94	1,57	1,29	1,01

### EXAMPLE OF TOTAL $\Delta p$ CALCULATION

FDD040XD100G10ABB5DS000S0 with **40** l/min and oil **46** cSt:

Housing  $\Delta p$  0,38 bar + element  $D_p$  0,39 bar ( $40 \times 6,75/1000 \times 46/32$ ) = total assembly  $\Delta p$  0,77 bar.

N.B. All the reported data have been obtained at our laboratory, according to specification ISO3968 with mineral oil having 32 cSt viscosity and density 0,875 Kg/dm<sup>3</sup>.

For more information:

WEB: FLTR.com.au PHONE: (+61) 1300 62 4020 EMAIL: info@FLTR.com.au

## USER TIPS



### INDICATOR TIGHTENING TORQUE

50 Nm

### SPARE SEAL KIT PART NUMBER (5)

	NBR
XD040-063-100	06.021.00322
XD160-250-400	06.021.00324

### BOWL TIGHTENING TORQUE

screw up filter bowl till end

## WARNING

- ⚠ Make sure that Personal Protective Equipment (PPE) is worn during installation and maintenance operation.

## DISPOSAL OF FILTER ELEMENT

- ⚠ The used filter elements and the filter parts dirty of oil are classified as "Dangerous waste material": they must be disposed according to the local laws by authorized Companies.

## INSTALLATION

- ⚠ 1. The IN and OUT ports must be connected to the hoses in the correct flow direction an arrow shows on the filter head (1).
- 2. The filter housing should be preferably mounted with the bowl (6) downward.
- 3. Secure to the frame the filter head (1) using the threaded fixing holes (3).
- 4. Verify that no tension is present on the filter after mounting.
- 5. Enough space must be available for filter element replacement.
- 6. The visual clogging indicator must be in a easily viewable position.
- 7. When a electrical indicator is used, make sure that it is properly wired.
- 8. Never run the system with no filter element fitted.
- ⚠ 9. Keep in stock a spare FILTREC filter element for timely replacement when required.
- 10. Filter housing should be earthed.

## OPERATION

- ⚠ 1. The filter must work within the operating conditions of pressure, temperature and compatibility given in the first page of this data sheet.
- 2. The filter element must be replaced as soon as the clogging indicator signals at working temperature (in cold start conditions, oil temperature lower than 30°C, a false alarm can be given due to oil viscosity).
- 3. If no clogging indicator is mounted, replace the element according to the system manufacturer's recommendations.

## MAINTENANCE

- ⚠ 1. Operate and hold pressure equalizing lever located behind switching lever. Pull catch knob and swivel switching lever. Engage the catch on the clear filter side. Place through or drip pan underneath to collect leaving oil.
- 2. Loosen vent screw of the filter side not in use by 2-3 turns; max. until contact is made with the safety stop.
- 3. Unscrew filter bowl by rotating same counter-clockwise and clean with a suitable medium.  
Warning: The shift lever may not, from now until the screwing back in of the filter bowl, be activated under any circumstances!
- 4. Remove filter element with a side-to-side motion.
- 5. Check O-ring on the filter bowl for damage and replace, if necessary.
- ⚠ 6. Make sure that the order number on the spare element corresponds to the order number of the filter name-plate.
- 7. Lightly lubricate the threads of the filter bowl and screw into the filter head.
- 8. To refill the filter chamber, operate only the pressure equalizing lever (leave the switching lever arrested in its catch) long enough for the medium to emerge bubble-free from the vent bore.
- 9. Tighten vent screw and check filter for leaks by operating the pressure equalizing lever once again.