



## FDD315 SERIES

Duplex high pressure filters

Inline filters for operating pressure up to 315 bar, flow rate up to 400 l/min. Duplex construction for uninterrupted service. Change over valve on upstream side, ergonomic switch-over handle with safety lock and pressure compensation. Filter elements sizes according to DIN 24550



### HOUSING

tested according to NFPA T3.10.5.1, ISO 10771, ISO 3968

**PRESSURE:** max operating 315 bar sizes 040 to 100  
max operating 200 bar sizes 160 to 400

**CONNECTIONS:** G 1"  
G 1 1/2"  
SAE Flange 1 1/2" 3000 psi

**MATERIALS:** Head: painted cast iron  
Bowl: painted carbon steel  
Seal: NBR

**BYPASS VALVE:** 7 bar

### ELEMENT

tested according to ISO 11170, 2941, 2942, 2943, 3724, 3968, 16889, 16908, 23181

**FILTER MEDIA:** glassfiber G01 - G03 - G06 - G10 - G15  
G25

**COLLAPSE PRESSURE:** 20 bar  
210 bar

**TEMPERATURE RANGE:** -30°C +100°C

**FLUID COMPATIBILITY:** Full with HH-HL-HM-HV  
HETG-HEES (acc. to ISO 6743/4).  
For use with other fluid please  
contact Filtrac Customer Service  
([info@filtrac.it](mailto:info@filtrac.it)).

For more information:

WEB: [FLTR.com.au](http://FLTR.com.au) PHONE: (+61) 1300 62 4020 EMAIL: [info@FLTR.com.au](mailto:info@FLTR.com.au)

## OVERALL DIMENSIONS

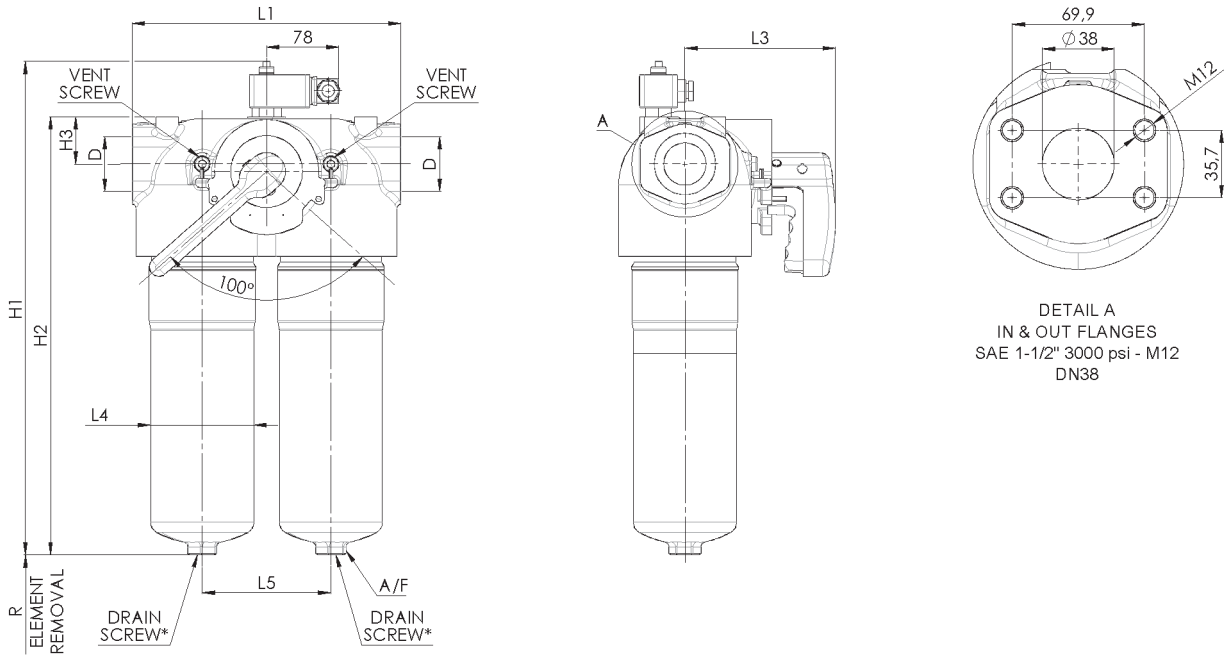

\* AVAILABLE FOR SIZES FDD040XD250 AND FDD040XD400 ONLY

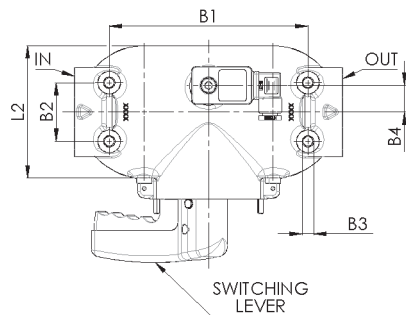

## NOMINAL SIZE

MODEL	B1	B2	B3	B4	D	L1	L2	L3	L4	L5	H1	H2	H3	A/F	R	kg
FDD315XD040											285	228				10,5
FDD315XD063	100	55	M8 x12	10	G 1"	182	90	144	66	86	345	288	38	27	80	12
FDD315XD100											427	370				14
FDD315XD160											363	311				30
FDD315XD250	210	62	M12 x18	28	G 1 1/2"	280	140	160	110	136	463	412	50	30	110	35
FDD315XD400					SAE FLANGE 1-1/2" 3000 psi - M12						614	562		30		41

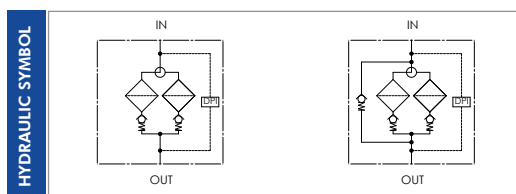

For more information:

WEB: [FLTR.com.au](http://FLTR.com.au) PHONE: (+61) 1300 62 4020 EMAIL: [info@FLTR.com.au](mailto:info@FLTR.com.au)

## ORDERING INFORMATION

	1.	2.	3.	4.	5.	6.	7.	8.	9.	10.	11.	12.
	<b>FDD315</b>	<b>XD</b>	<b>100</b>	<b>G10</b>	<b>A</b>	<b>B</b>	<b>B5</b>	<b>D</b>	<b>S</b>	<b>000</b>	<b>S</b>	<b>0</b>
SPARE ELEMENT		<b>XD</b>	<b>100</b>	<b>G10</b>	<b>A</b>							

1. FILTER SERIES	FDD315	
2. FILTER ELEMENT SERIES	XD	
3. FILTER SIZE	040-063-100	
	160-250-400	
4. FILTER MEDIA	000	no element
	G01	glassfiber $\beta_{4\mu\text{m(c)}} > 1.000$
	G03	glassfiber $\beta_{5\mu\text{m(c)}} > 1.000$
	G06	glassfiber $\beta_{7\mu\text{m(c)}} > 1.000$
	G10	glassfiber $\beta_{12\mu\text{m(c)}} > 1.000$
	G15	glassfiber $\beta_{17\mu\text{m(c)}} > 1.000$
	G25	glassfiber $\beta_{22\mu\text{m(c)}} > 1.000$
5. ELEMENT COLLAPSE	A	21 bar
	B	210 bar
6. SEALS	B	NBR
7. CONNECTIONS	B5	G 1" for sizes 040-063-100
	B7	G 1 1/2" for sizes 160-250
	F7M	1 1/2" SAE 3000 psi-M12 for sizes 400
8. BYPASS VALVE	0	no by-pass
	D	7 bar
9. INDICATOR PORT OPTION	S	with metal plug
10. COMPULSORY FIELD	000	filtrec standard
11. CORROSION PROTECTION	S	standard
12. OPTION	0	no option

## ACCESSORIES

The accessories must be ordered separately

INDICATOR For indicators detail see service instructions	FG5	differential visual and electric 5 bar
	FG8	differential visual and electric 8 bar recommended for no bypass option

For more information:

WEB: [FLTR.com.au](http://FLTR.com.au) PHONE: (+61) 1300 62 4020 EMAIL: [info@FLTR.com.au](mailto:info@FLTR.com.au)

## PRESSURE DROP ( $\Delta p$ ) INFORMATION FOR FILTER SIZING

The total Delta P through a filter assembly is given from Housing  $\Delta p$  + Element  $\Delta p$ .

This ideally should not exceed 1,0 bar and should never exceed 1/3 of the set value of the by-pass valve. N.B. All the reported data have been obtained at our laboratory, according to specification ISO3968 with mineral oil having 32 cSt viscosity and density 0,875 Kg/dm<sup>3</sup>.

### HOUSING PRESSURE DROP

The housing  $\Delta p$  is given by the curve of the considered model and port, in correspondence of the flow rate value.

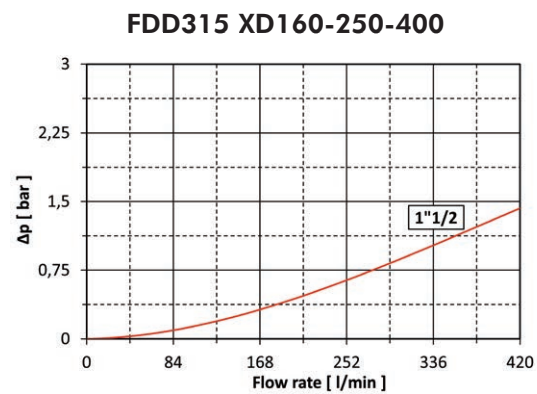
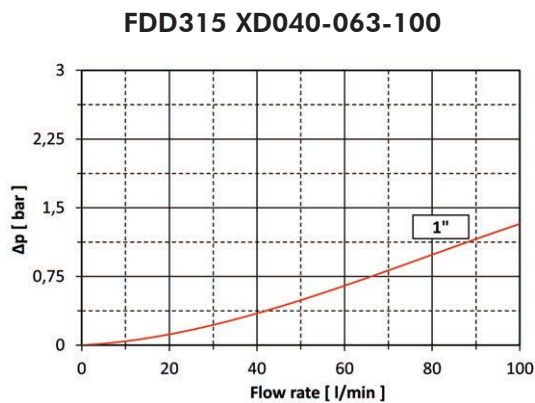

### ELEMENT PRESSURE DROP

The element  $\Delta p$  (bar) is given by the flow rate (l/min) multiplied by the factor in the table here below corresponding to the selected media and divided by 1000.

If the oil has a viscosity  $V_x$  different than 32 cSt a corrective factor  $V_x/32$  must be applied.

Example: 40 l/min with XD100G10A and oil viscosity 46 cSt:  $40 \times 3,6/1000 \times 46/32 = 0,21$  bar.

	G01A	G03A	G06A	G10A	G15A	G25A
<b>XD040</b>	22	15,4	13,5	7,88	6,75	5,63
<b>XD063</b>	16,15	11,31	9	5,54	4,85	4,15
<b>XD100</b>	12	8,4	5,85	3,6	3,15	2,7
<b>XD160</b>	7,81	5,47	4,47	2,63	1,84	1,49
<b>XD250</b>	5,2	3,64	2,61	1,68	0,91	0,86
<b>XD400</b>	3,25	2,28	1,52	1,12	0,64	0,57

### EXAMPLE OF TOTAL $\Delta p$ CALCULATION

FDD315XD100G10ABB5DS000S0 with 40 l/min and oil 46 cSt:

Housing  $\Delta p$  0,38 bar + element  $\Delta p$  0,45 bar ( $40 \times 3,6/1000 \times 46/32$ ) = total assembly  $\Delta p$  0,59 bar.

## ELEMENT PRESSURE DROP (filter elements 210 bar collapse)

The element  $\Delta p$  (bar) is given by the flow rate (l/min) multiplied by the factor in the table here below corresponding to the selected media and divided by 1000.

If the oil has a viscosity  $V_x$  different than 32 cSt a corrective factor  $V_x/32$  must be applied.

Example: 40 l/min with XD100G10B and oil viscosity 46 cSt:  $40 \times 6,75/1000 \times 46/32 = 0,39$  bar.

	<b>G01B</b>	<b>G03B</b>	<b>G06B</b>	<b>G10B</b>	<b>G15B</b>	<b>G25B</b>
<b>XD040</b>	34,97	24,48	22,5	14,63	12,38	10,13
<b>XD063</b>	29,23	20,46	16,62	10,38	8,65	6,92
<b>XD100</b>	19	13,3	10,35	6,75	5,85	4,95
<b>XD160</b>	8,13	5,69	4,74	3,37	2,81	2,25
<b>XD250</b>	5,4	3,78	3,06	2,52	2,16	1,8
<b>XD400</b>	3,38	2,36	1,94	1,57	1,29	1,01

## EXAMPLE OF TOTAL $\Delta p$ CALCULATION

FDD315XD100G10ABB5DS000S0 with **40** l/min and oil **46** cSt:

Housing  $\Delta p$  0,38 bar + element  $\Delta p$  0,84 bar ( $40 \times 6,75/1000 \times 46/32$ ) = total assembly  $\Delta p$  0,77 bar.

N.B. All the reported data have been obtained at our laboratory, according to specification ISO3968 with mineral oil having 32 cSt viscosity and density 0,875 Kg/dm<sup>3</sup>.

For more information:

WEB: [FLTR.com.au](http://FLTR.com.au) PHONE: (+61) 1300 62 4020 EMAIL: [info@FLTR.com.au](mailto:info@FLTR.com.au)

## USER TIPS



### INDICATOR TIGHTENING TORQUE

90 Nm

### SPARE SEAL KIT PART NUMBER (5)

	NBR
XD040-063-100	06.021.00328
XD160-250-400	06.021.00330

### BOWL TIGHTENING TORQUE

screw up filter bowl till end

## WARNING

- ⚠ Make sure that Personal Protective Equipment (PPE) is worn during installation and maintenance operation.

## DISPOSAL OF FILTER ELEMENT

- ⚠ The used filter elements and the filter parts dirty of oil are classified as "Dangerous waste material": they must be disposed according to the local laws by authorized Companies.

## INSTALLATION

- ⚠ 1. The IN and OUT ports must be connected to the hoses in the correct flow direction an arrow shows on the filter head (1).
- 2. The filter housing should be preferably mounted with the bowl (6) downward.
- 3. Secure to the frame the filter head (1) using the threaded fixing holes (3).
- 4. Verify that no tension is present on the filter after mounting.
- 5. Enough space must be available for filter element replacement.
- 6. The visual clogging indicator must be in a easily viewable position.
- 7. When a electrical indicator is used, make sure that it is properly wired.
- ⚠ 8. Never run the system with no filter element fitted.
- 9. Keep in stock a spare FILTREC filter element for timely replacement when required.
- 10. Filter housing should be earthed.

## OPERATION

- ⚠ 1. The filter must work within the operating conditions of pressure, temperature and compatibility given in the first page of this data sheet.
- 2. The filter element must be replaced as soon as the clogging indicator signals at working temperature (in cold start conditions, oil temperature lower than 30°C, a false alarm can be given due to oil viscosity).
- 3. If no clogging indicator is mounted, replace the element according to the system manufacturer's recommendations.

## MAINTENANCE

- ⚠ 1. Operate and hold pressure equalizing lever located behind switching lever. Pull catch knob and swivel switching lever. Engage the catch on the clear filter side. Place through or drip pan underneath to collect leaving oil.
- 2. Loosen vent screw of the filter side not in use by 2-3 turns; max. until contact is made with the safety stop.
- 3. Unscrew filter bowl by turning counter-clockwise. Clean the bowl using a suitable cleaning solvent. Warning: The shift lever may not, from now until the screwing back in of the filter bowl, be activated under any circumstances!
- 4. Remove filter element by pulling down carefully.
- 5. Check o-ring on the filter housing for damage. Replace, if necessary.
- ⚠ 6. Make sure that the order number on the spare element corresponds to the order number of the filter name-plate. To ensure no contamination occurs during the exchange of the element first open the plastic bag and push the element over the spigot in the filter head. Now remove plastic bag.
- 7. Lightly lubricate the threads of the filter bowl and screw into the filter head.
- 8. To refill the filter chamber, operate only the pressure equalizing lever (leave the switching lever arrested in its catch) long enough for the medium to emerge bubble-free from the vent bore.
- 9. Tighten vent screw. Check filter for leaks by operating the pressure equalizing lever once again.

For more information:

WEB: FLTR.com.au PHONE: (+61) 1300 62 4020 EMAIL: info@FLTR.com.au