

## FH420 SERIES THREADED

In line high pressure filters

In line filters for operating pressure up to 420 bar.  
Flow rate up to 500 l/min.



### HOUSING

tested according to NFPA T3.10.5.1, ISO 10771, ISO 3968

**PRESSURE:** Max operating: up to 420 bar  
Fatigue rating:  $10^6$  cycles 0÷420 bar  
Burst: 1260 bar

**CONNECTIONS:** G 1/2" ÷ G 1 1/2"

**MATERIALS:** Head: cast iron  
Bowl: carbon steel  
Seal: NBR (FKM on request)

**BYPASS VALVE:** 6 bar  
ABF valve  
ABF valve+RF valve

### ELEMENT

tested according to ISO 11170, 2941, 2942, 2943, 3724, 3968, 16889, 16908, 23181

**FILTER MEDIA:** Fibreglass: G01 - G03 - G06 - G10  
G15 - G25

**COLLAPSE PRESSURE:** 21 bar  
210 bar

**TEMPERATURE RANGE:** with NBR seal  
from -30 °C to +100 °C

with FKM seal (OPTION)  
from -25 °C to +120 °C

**FLUID COMPATIBILITY:** Full with HH-HL-HM-HV  
HETG-HEES (acc. to ISO 6743/4).  
For use with other fluid please  
contact Filtrec Customer Service  
(info@filtrec.it).

**OVERALL DIMENSIONS**

FH420-D1-2x

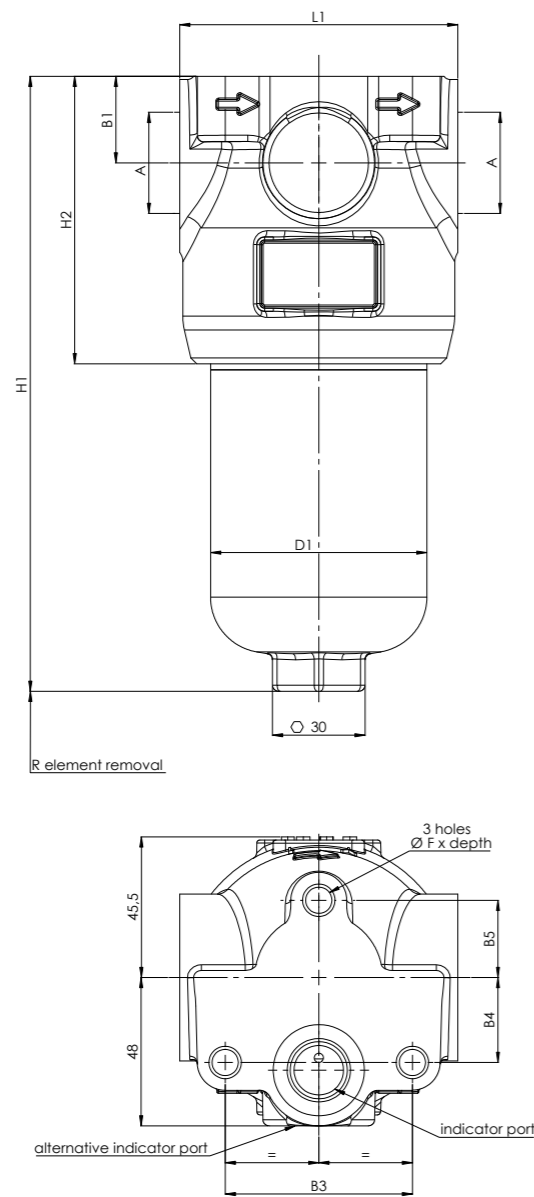

**NOMINAL SIZE**

MODEL	A	B1	B3	B4	B5	D1	F	H1	H2	L1	R	WEIGHT
FH420-D125								162				3,5 Kg
FH420-D120	G 1/2"							203				4 Kg
FH420-D124	G 3/4"	28	60,6	27,5	25	70	M10x15	246	93	90	110	4,5 Kg
FH420-D121	G 1"							296				5 Kg
FH420-D126								340				5,4 Kg

**OVERALL DIMENSIONS**

FH420-D1-3x

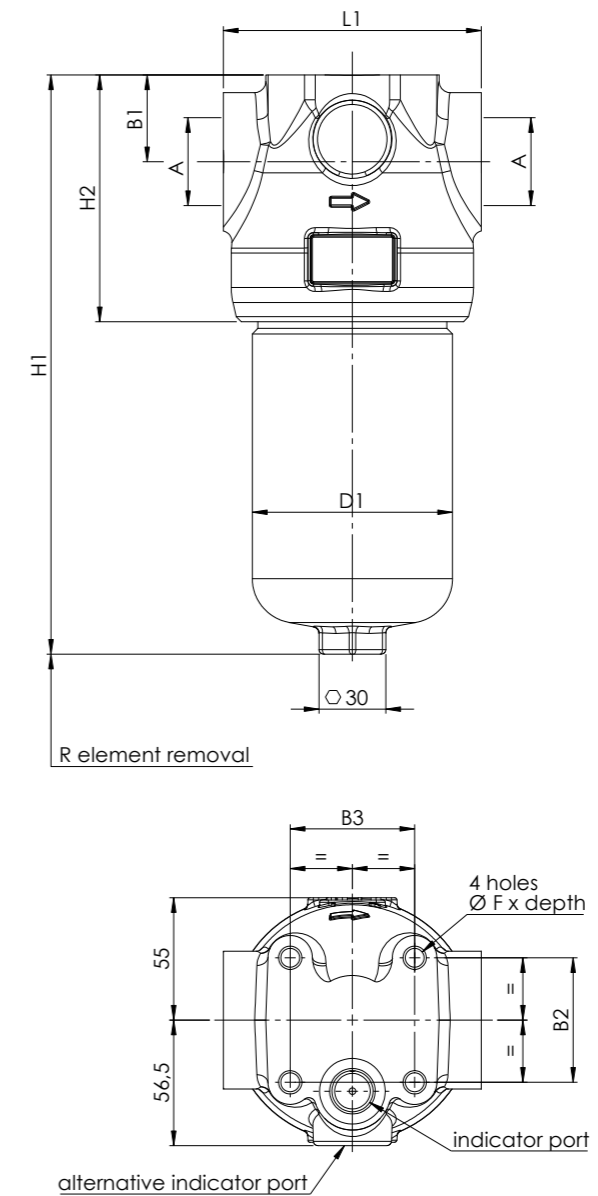

**NOMINAL SIZE**

MODEL	A	B1	B2	B3	D1	F	H1	H2	L1	R	WEIGHT
FH420-D135							261				7,4 Kg
FH420-D136	G 1"	39	56	56	90	M10x15	320	111	116	120	8,5 Kg
FH420-D137	G 1 1/4"						390				9,9 Kg

**OVERALL DIMENSIONS**

FH420-D1-4x

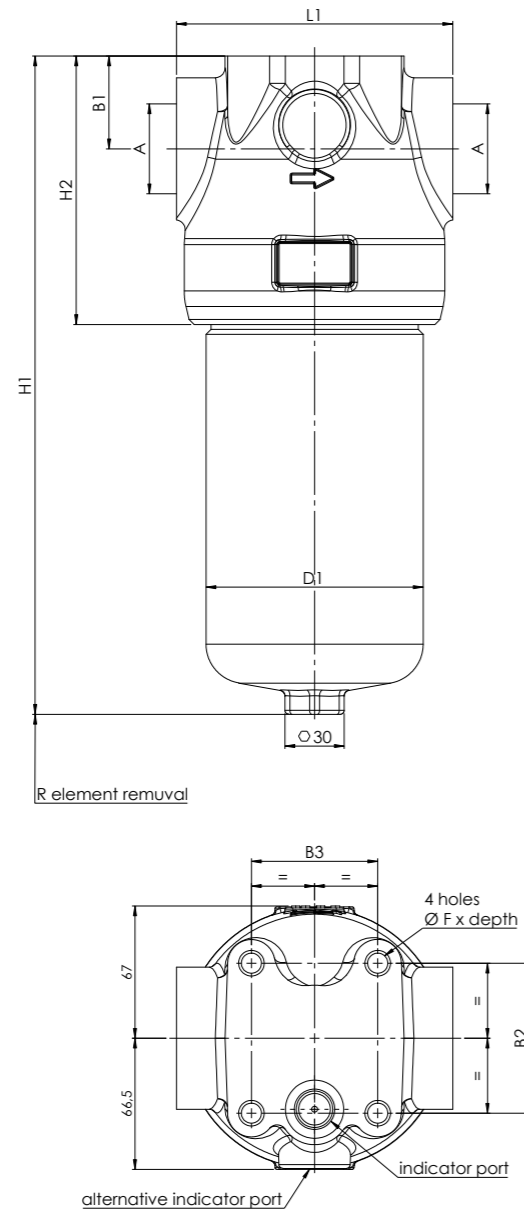

**NOMINAL SIZE**

MODEL	A	B1	B2	B3	D1	F	H1	H2	L1	R	WEIGHT
FH420-D140							240,5				10,5 Kg
FH420-D141	G 1 1/4"	47	76	64	110	M12x18	333,5	136	140	130	13 Kg
FH420-D142	G 1 1/2"						453,5				16,4 Kg
FH420-D143							552,5				19 Kg

**ORDERING INFORMATION**

	1.	2.	3.	4.	5.	6.	7.	8.	9.	10.	11.	12.	13.
	<b>FH420</b>	<b>D1</b>	<b>20</b>	<b>G10</b>	<b>A</b>	<b>B</b>	<b>B4</b>	<b>D</b>	<b>C</b>	<b>W</b>	<b>E05</b>	<b>S</b>	<b>0</b>
SPARE ELEMENT	<b>D1</b>	<b>20</b>	<b>G10</b>	<b>A</b>									

1. FILTER SERIES	FH420	
2. FILTER ELEMENT SERIES	D1	
3. FILTER SIZE	25-20-24-21-26 35-36-37 40-41-42-43	
4. FILTER MEDIA	000	no element
	G01	glassfiber $\beta_{4\mu m(c)} \geq 1.000$
	G03	glassfiber $\beta_{5\mu m(c)} \geq 1.000$
	G06	glassfiber $\beta_{7\mu m(c)} \geq 1.000$
	G10	glassfiber $\beta_{12\mu m(c)} \geq 1.000$
	G15	glassfiber $\beta_{17\mu m(c)} \geq 1.000$
	G25	glassfiber $\beta_{22\mu m(c)} \geq 1.000$
5. ELEMENT COLLAPSE	A	21 bar
	Y	21 bar - with ABF / RF valve
	B	210 bar
	X	210 bar - with ABF / RF valve
6. SEALS	*B	NBR
	V	FKM (on request)
*omitted for spare element		
7. CONNECTIONS	B3	G 1/2" for size 2x
For different thread options please check availability with Filtrec Customer Service.	B4	G 3/4" for size 2x - 3x
	B5	G 1" for size 2x - 3x
	B6	G 1 1/4" for size 3x - 4x
	B7	G 1 1/2" for size 4x
8. BYPASS VALVE	0	no by-pass
	D	6 bar
9. ABF VALVE / RF VALVE	0	no valve
ABF=anti back flow valve	C	ABF valve
RF= reverse flow valve	R	ABF valve+RF valve
10. INDICATOR PORT OPTION	S	with metal plug
	W	with plastic plug
11. INDICATOR	000	no indicator
(F) digit for FKM seal option	V05 (VF5)	differential visual 5 bar
*LC24=Led connector	E05 (EF5)	differential electrical 5 bar
For other options see clogging indicators catalogue	E05L (EF5L)	differential electrical 5 bar + *LC24
	V08 (VF8)	differential visual 8 bar
	E08 (EF8)	differential electrical 8 bar recommended for no by-pass option
	E08L (EF8L)	differential electric 8 bar + *LC24
12. CORROSION PROTECTION	S	phosphated - standard
13. OPTION	0	standard
	D	drain plug (on request) standard on size 43

**HYDRAULIC SYMBOLS**

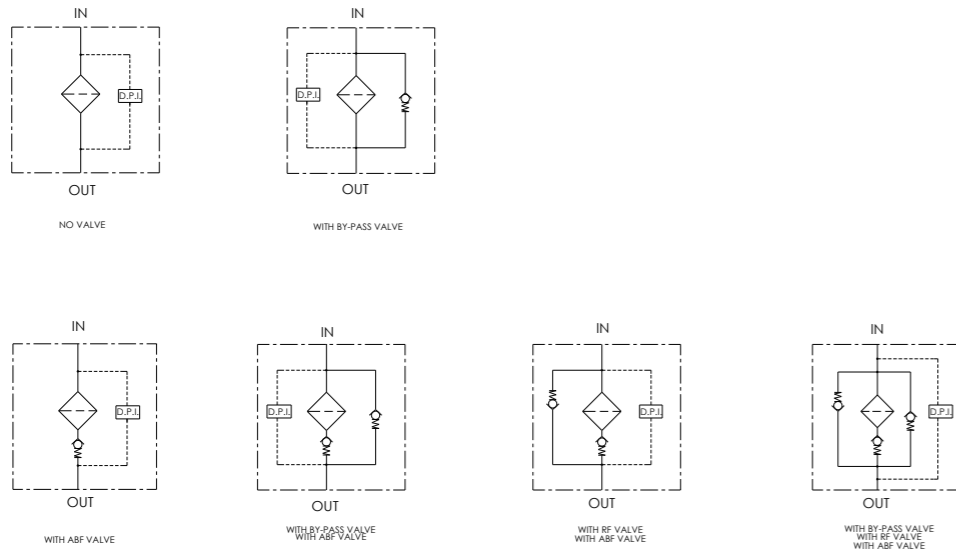

**PRESSURE DROP ( $\Delta p$ ) INFORMATION FOR FILTER SIZING**

The total Delta P through a filter assembly is given from Housing  $\Delta p$  + Element  $\Delta p$ . This ideally should not exceed 1,0 bar and should never exceed 1/3 of the set value of the by-pass valve. N.B. All the reported data have been obtained at our laboratory, according to specification ISO3968 with mineral oil having 32 cSt viscosity and density 0,875 Kg/dm<sup>3</sup>.

**HOUSING PRESSURE DROP**

The housing  $\Delta p$  is given by the curve of the considered model and port, in correspondence of the flow rate value.

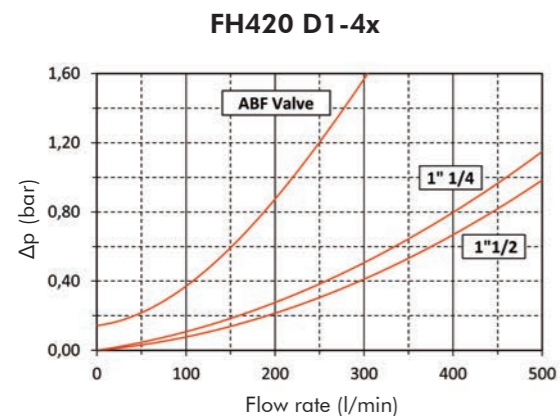
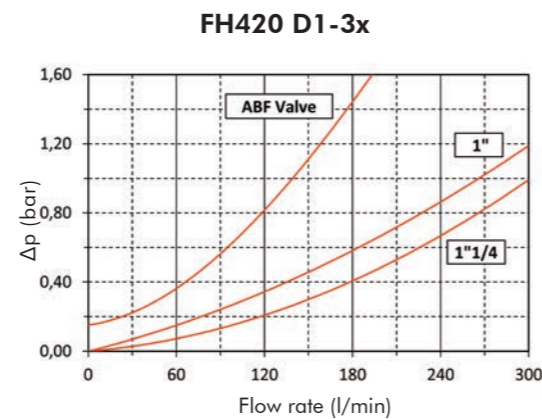
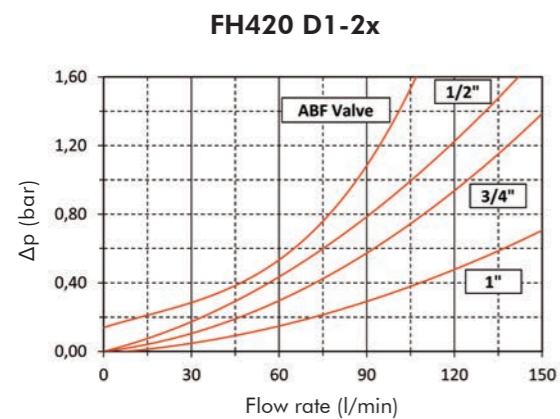

**ELEMENT PRESSURE DROP (filter elements 21 bar collapse)**

The element  $\Delta p$  (bar) is given by the flow rate (l/min) multiplied by the factor in the table here below corresponding to the selected media and divided by 1000. If the oil has a viscosity  $V_x$  different than 32 cSt a corrective factor  $V_x/32$  must be applied. Example: 80 l/min with D121G10A and oil viscosity 46 cSt  $> (80 \times 4,42)/1000 \times (46/32) = 0,51$  bar

	G01	G03	G06	G10	G15	G25
D125	50,24	35,56	25,75	15,51	8,27	7,57
D120	30,43	21,30	13,97	8,39	5,18	4,78
D124	19,90	13,93	8,42	5,17	4,16	3,60
D121	15,48	10,84	6,79	4,42	3,38	2,93
D126	13,24	8,61	5,75	4,03	2,91	2,43
D135	15,82	11,07	7,27	4,45	3,03	2,87
D136	13,19	9,23	6,06	3,71	2,53	2,39
D137	9,63	6,74	4,43	2,71	1,85	1,75
D140	14,65	10,26	6,73	4,12	2,81	2,66
D141	6,88	4,82	2,98	2,02	1,42	1,21
D142	4,67	3,27	1,99	1,36	1,04	0,77
D143	3,28	2,30	1,26	0,70	0,56	0,40

**EXAMPLE OF TOTAL  $\Delta p$  CALCULATION**

FH420D121G10ABB5DCWE05S0 with 80 l/min and oil 46 cSt: Housing  $\Delta p$  0,25 bar + element  $\Delta p$  0,51 bar  $(80 \times 4,42)/1000 \times (46/32) =$  total assembly  $\Delta p$  0,76 bar

**ELEMENT PRESSURE DROP (filter elements 210 bar collapse)**

The element  $\Delta p$  (bar) is given by the flow rate (l/min) multiplied by the factor in the table here below corresponding to the selected media and divided by 1000. If the oil has a viscosity  $V_x$  different than 32 cSt a corrective factor  $V_x/32$  must be applied. Example: 80 l/min with D121G10B and oil viscosity 46 cSt  $> (80 \times 5,25)/1000 \times (46/32) = 0,60$  bar

	G01	G03	G06	G10	G15	G25
D125	57,38	89,23	27,5	16,53	10,15	8,03
D120	37,18	26,03	14,77	11,57	6,89	6,13
D124	24,56	17,19	11,37	6,63	4,93	3,92
D121	23,89	16,72	11,25	5,25	3,85	3,34
D126	17,65	11,48	7,79	5,17	3,55	2,85
D135	20,27	14,19	9,50	5,66	4,01	3,41
D136	16,90	11,83	7,92	4,72	3,34	2,84
D137	12,35	8,64	5,79	3,45	2,44	2,07
D140	18,57	13,00	9,63	5,05	3,74	3,33
D141	10,22	7,15	4,00	2,57	1,76	1,44
D142	5,53	3,87	2,93	1,67	1,12	0,83
D143	4,59	3,21	1,80	1,10	0,93	0,70

**EXAMPLE OF TOTAL  $\Delta p$  CALCULATION**

FH420D121G10BBB5DCWE05S0 with 80 l/min and oil 46 cSt : Housing  $\Delta p$  0,25 bar + element  $\Delta p$  0,60 bar  $(80 \times 5,25)/1000 \times (46/32) =$  total assembly  $\Delta p$  0,85 bar

## BYPASS VALVE PRESSURE DROP

The bypass valve  $\Delta p$  is given by the curve of the considered model and setting, in correspondence of the flow rate value.

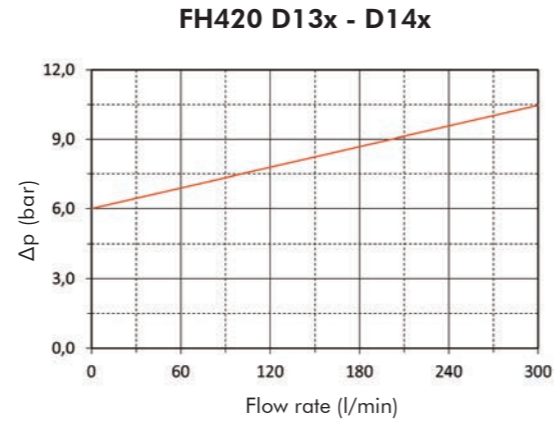
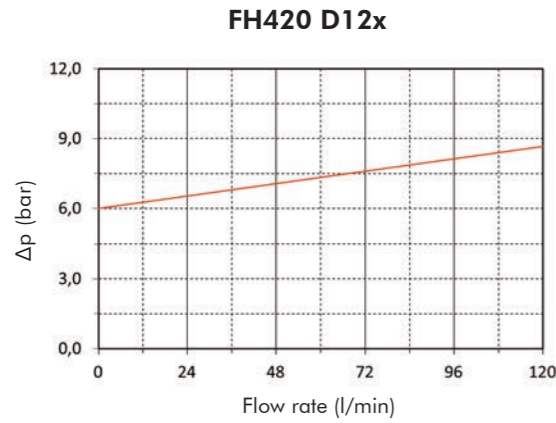

## RF VALVE PRESSURE DROP

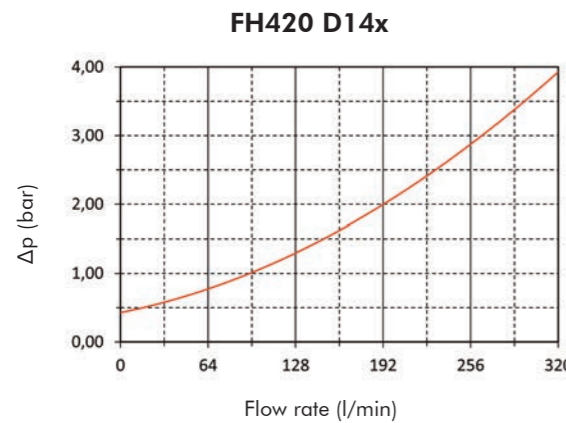
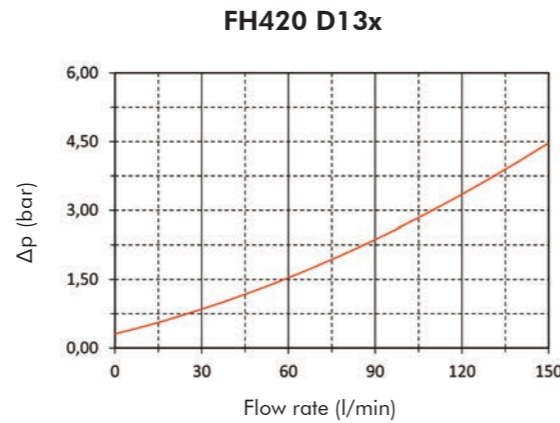
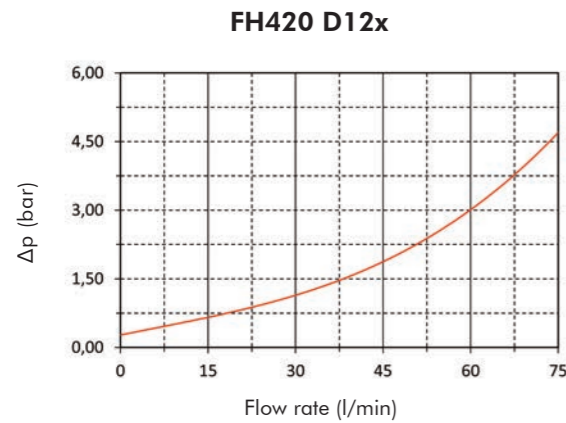

## USER TIPS



- 1 FILTER HEAD
- 2 INDICATOR PORT
- 3 FIXING HOLES
- 4 FILTER ELEMENT
- 5 SEAL KIT
- 6 FILTER BOWL
- 7 IDENTIFICATION LABEL
- 8 DRAIN PLUG
- 9 INDICATOR PLUG

### INDICATOR TIGHTENING TORQUE

90 Nm

### SPARE SEAL KIT PART NUMBER

	NBR	FKM
FH420 D1-2x	06.021.00268	06.021.00269
FH420 D1-3x	06.021.00270	06.021.00271
FH420 D1-4x	06.021.00272	06.021.00273

### BOWL TIGHTENING TORQUE

screw up filter bowl till end

### WARNING

- ⚠ Make sure that Personal Protective Equipment (PPE) is worn during installation and maintenance operation.

### DISPOSAL OF FILTER ELEMENT

- ⚠ The used filter elements and the filter parts dirty of oil are classified as "Dangerous waste material": they must be disposed according to the local laws by authorized Companies.

## INSTALLATION

- ⚠ 1. the IN and OUT ports must be connected to the hoses in the correct flow direction (an arrow shows on the filter head (1))
- 2. the filter housing should be preferably mounted with the bowl (6) downward
- 3. secure to the frame the filter head (1) using the threaded fixing holes (3)
- 4. verify that no tension is present on the filter after mounting
- 5. enough space must be available for filter element replacement
- 6. the visual clogging indicator must be in a easily viewable position
- 7. when a electrical indicator is used, make sure that it is properly wired
- ⚠ 8. never run the system with no filter element fitted
- 9. keep in stock a spare FILTREC filter element for timely replacement when required
- 10. filter housing should be earthed

## OPERATION

- ⚠ 1. the filter must work within the operating conditions of pressure, temperature and compatibility given in the first page of this data sheet
- 2. the filter element must be replaced as soon as the clogging indicator signals at working temperature (in cold start conditions, oil temperature lower than 30°C, a false alarm can be given due to oil viscosity)
- 3. If no clogging indicator is mounted, replace the element according to the system manufacturer's recommendations

## MAINTENANCE

- ⚠ 1. make sure that the system is switched off and there is no residual pressure in the filter
- 2. unscrew the bowl (6) by turning it anti-clockwise and remove it
- 3. remove the dirty element (4)
- 4. fit a new FILTREC element (4), verifying the part number, particularly concerning the micron rating; open its plastic protection on the open end side and insert it onto the spigot in the filter head, then remove completely the plastic protection
- 5. clean carefully the bowl; check the O-rings (5) conditions and replace if necessary
- 6. lubricate the bowl's thread (6) and screw it by hand in the filter head (1) by turning it clockwise
- 7. screw in the bowl to stop
- ⚠ 8. the used filter elements cannot be cleaned and re-used

N.B. All the reported data have been obtained at our laboratory, according to specification ISO3968 with mineral oil having 32 cSt viscosity and density 0,875 Kg/dm<sup>3</sup>.