



FR6 SERIES

Tank top return filters

The FR6 filters are available with various configurations:

- With or without inbuilt air breather
- With 2, 4 or 6 tank mounting holes
- With or without supplementary inlet ports
- Flow rate up to 300 l/min



| | |
|-----------------------------|---|
| HOUSING | tested according to NFPA T3.10.5.1*, ISO 10771*, ISO 3968 |
| PRESSURE: | Max operating: 10 bar |
| CONNECTIONS: | Main ports: G 3/4" to 1 1/4" Additional ports (optional): G 1/2" to 1" |
| MATERIALS: | Head: aluminium alloy Bowl and top cover: PA6 reinforced Seal: NBR |
| BYPASS VALVE: | Inbuilt in the filter element B version 1,7 bar C version 3 bar |
| ELEMENT | tested according to ISO 11170, 2941, 2942, 2943, 3724, 3968, 16889, 16908, 23181 |
| FILTER MEDIA: | Inorganic microfiber G06 - G10 - G15 - G25 - G40 Paper: C10 Synthetic: M05 - M10 - M15 Metal wire mesh: T60 |
| COLLAPSE PRESSURE: | 10 bar |
| TEMPERATURE RANGE: | -30°C +100°C |
| FLUID COMPATIBILITY: | Full with HH-HL-HM-HV HETG-HEES (acc. to ISO 6743/4). For use with other fluid please contact Filtrac Customer Service (info@filtrac.it). |

* as reference method only for verifying the pressure fatigue resistance and establishing the burst pressure ratings.

For more information:

WEB: FLTR.com.au PHONE: (+61) 1300 62 4020 EMAIL: info@FLTR.com.au

2 MOUNTING HOLES

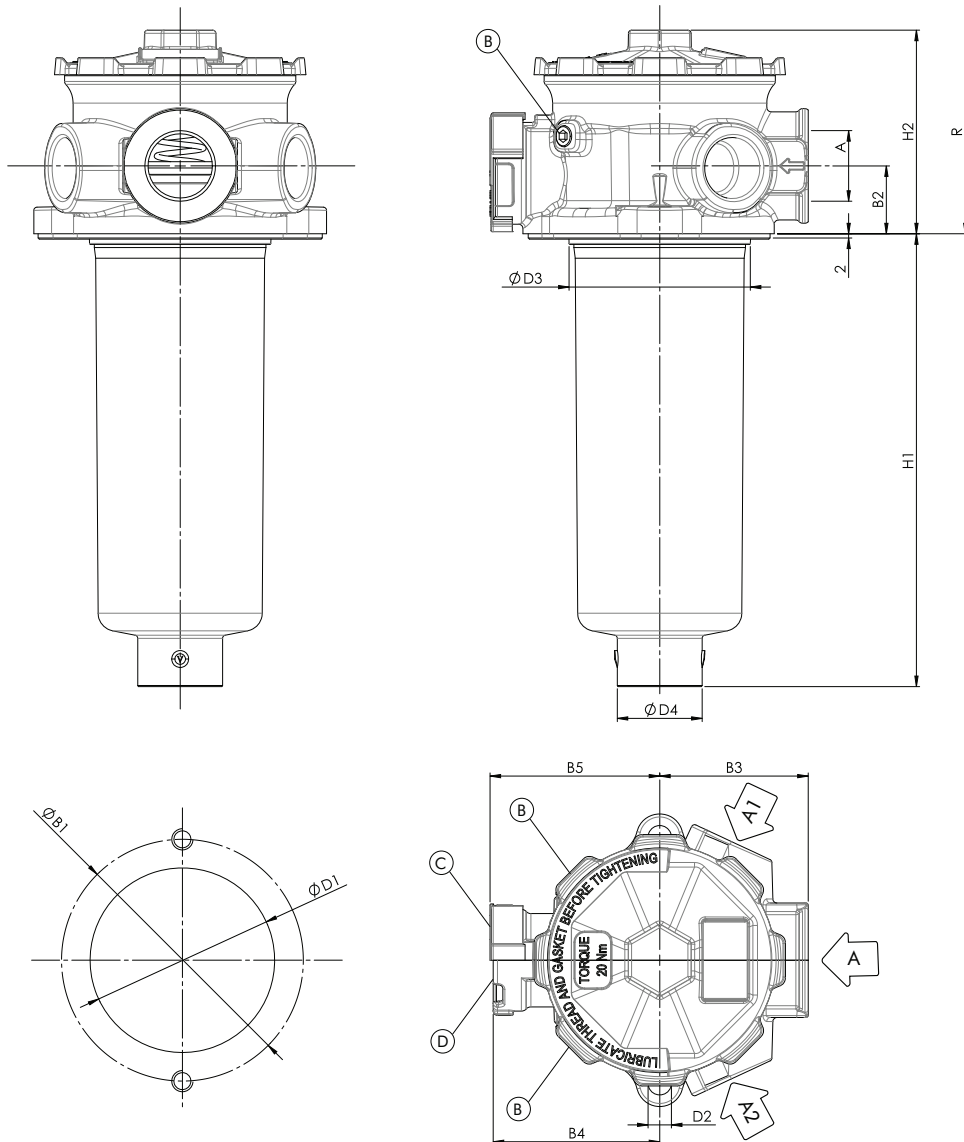

A1+A2= ON REQUEST ONLY
 B= INDICATOR PORTS
 C= VERSION WITH AIR BREATHER
 D= VERSION WITHOUT AIR BREATHER

NOMINAL SIZE

| MODEL | A | A1-A2 OPTIONAL | Ø B1 | B2 | B3 | B4 | B5 | Ø D1 | D2 | Ø D3 | Ø D4 | H1 | H2 | R | WEIGHT Kg |
|----------|----------|-------------------|-----------|----|----|----|----|---------|----|------|------|-----|----|-----|--------------|
| FR62R101 | | | | | | | | | | | | 104 | 77 | 200 | 0,8 |
| FR62R102 | G 3/4" | G 1/2" | 84 - 88 | 26 | 51 | 62 | 64 | 60 - 64 | 11 | 59 | 25 | 168 | 77 | 265 | 0,8 |
| FR62R104 | | | | | | | | | | | | 201 | 77 | 300 | 0,9 |
| FR62R120 | | | | | | | | | | | | 87 | 96 | 210 | 1,0 |
| FR62R122 | G 1" | | | | | | | | | | | 132 | 96 | 260 | 1,0 |
| FR62R130 | G 1 1/4" | G 1" | 114 - 116 | 32 | 70 | 78 | 80 | 87 - 91 | 11 | 86 | 40 | 214 | 96 | 340 | 1,1 |
| FR62R131 | | | | | | | | | | | | 318 | 96 | 440 | 1,2 |

4 MOUNTING HOLES

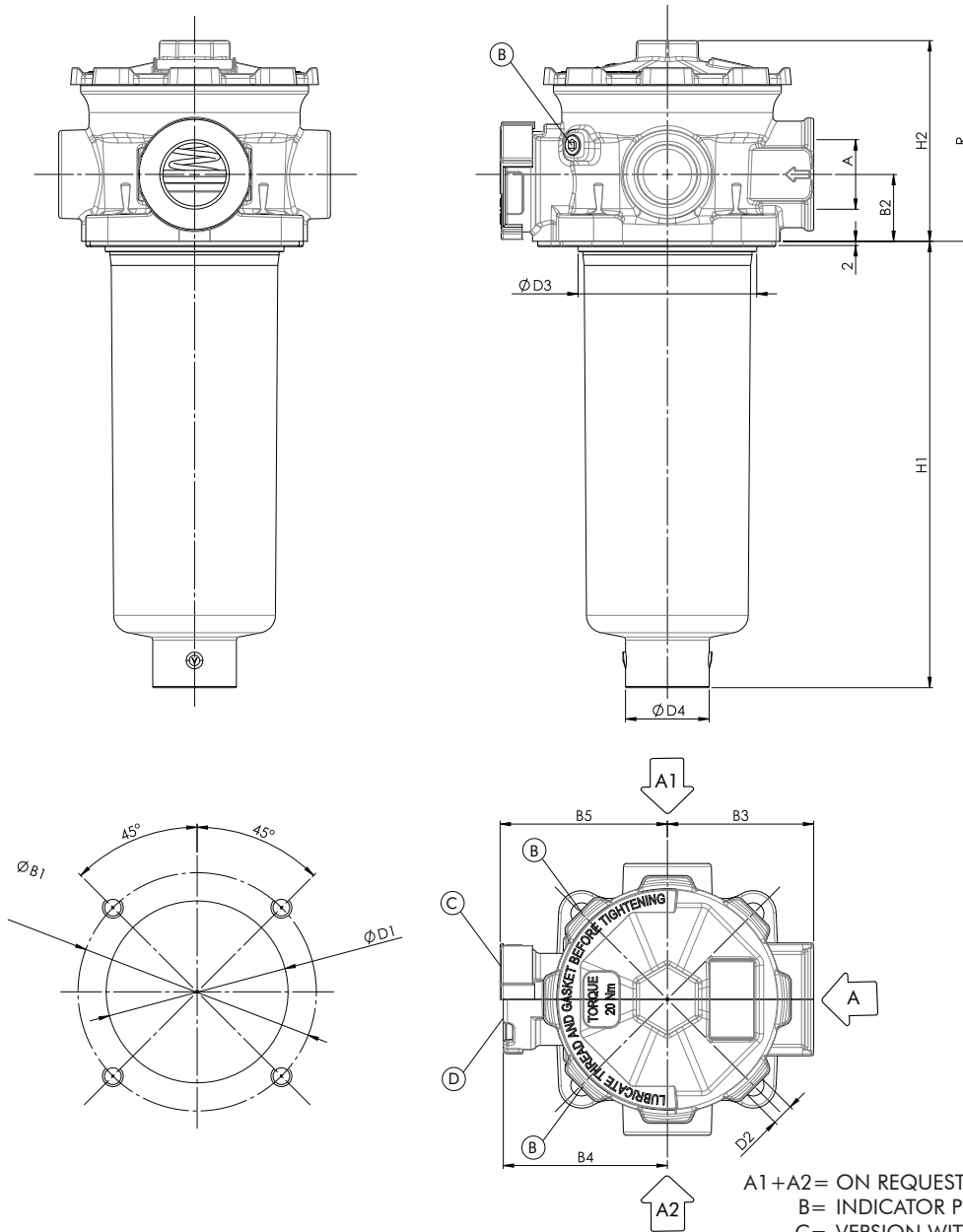

A1+A2= ON REQUEST ONLY
 B= INDICATOR PORTS
 C= VERSION WITH AIR BREATHER
 D= VERSION WITHOUT AIR BREATHER

NOMINAL SIZE

| MODEL | A | A1-A2 OPTIONAL | Ø B1 | B2 | B3 | B4 | B5 | Ø D1 | D2 | Ø D3 | Ø D4 | H1 | H2 | R | WEIGHT Kg |
|----------|----------|-------------------|-----------|----|----|----|----|---------|----|------|------|-----|----|-----|--------------|
| FR64R101 | | | | | | | | | | | | 104 | 77 | 200 | 0,9 |
| FR64R102 | G 3/4" | G 1/2" | 84 - 88 | 26 | 51 | 62 | 64 | 60 - 64 | 11 | 59 | 25 | 168 | 77 | 265 | 0,9 |
| FR64R104 | | | | | | | | | | | | 201 | 77 | 300 | 1,0 |
| FR64R120 | | | | | | | | | | | | 87 | 96 | 210 | 1,1 |
| FR64R122 | G 1" | | | | | | | | | | | 132 | 96 | 260 | 1,1 |
| FR64R130 | G 1 1/4" | G 1" | 114 - 116 | 32 | 70 | 78 | 80 | 87 - 91 | 11 | 86 | 40 | 214 | 96 | 340 | 1,2 |
| FR64R131 | | | | | | | | | | | | 318 | 96 | 440 | 1,3 |

For more information:

WEB: FLTR.com.au PHONE: (+61) 1300 62 4020 EMAIL: info@FLTR.com.au

6 MOUNTING HOLES can fit both 2 or 4 holes tank mounting pattern

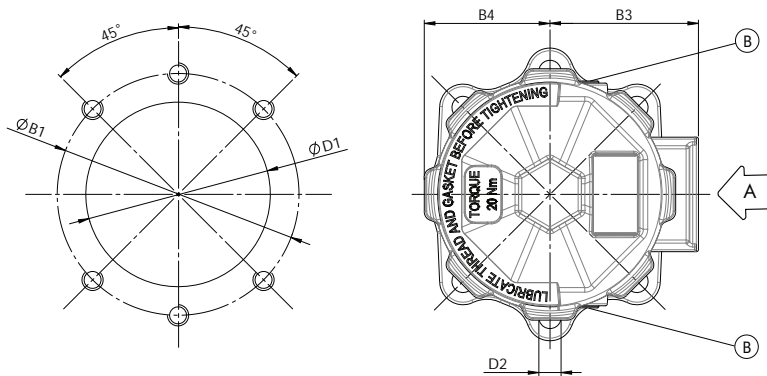
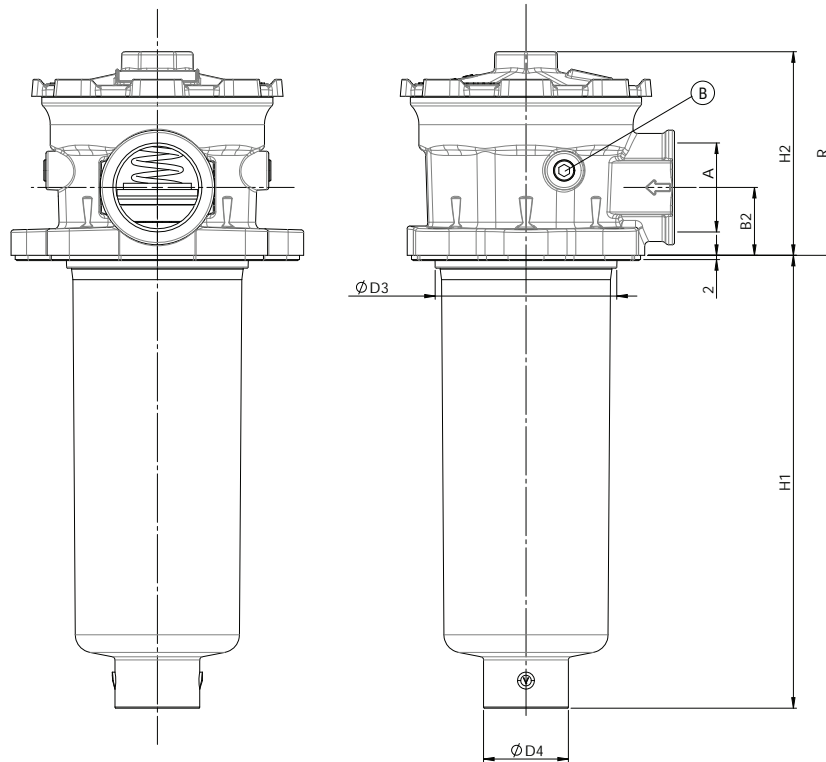

B= INDICATOR PORTS

NOMINAL SIZE

| MODEL | A | Ø B1 | B2 | B3 | B4 | B5 | Ø D1 | D2 | Ø D3 | Ø D4 | H1 | H2 | R | WEIGHT Kg |
|----------|----------|-----------|----|----|----|----|-------|----|------|------|-----|----|-----|-----------|
| FR66R120 | G 1" | 114 - 116 | 32 | 70 | 60 | 80 | 87-91 | 11 | 86 | 40 | 87 | 96 | 210 | 1,0 |
| FR66R122 | | | | | | | | | | | 132 | | | 260 |
| FR66R130 | G 1 1/4" | 114 - 116 | 32 | 70 | 60 | 80 | 87-91 | 11 | 86 | 40 | 214 | 96 | 340 | 1,1 |
| FR66R131 | | | | | | | | | | | 318 | | | 440 |

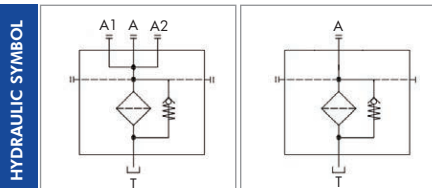

For more information:

WEB: FLTR.com.au PHONE: (+61) 1300 62 4020 EMAIL: info@FLTR.com.au

ORDERING INFORMATION



| 1. | 2. | 3. | 4. | 5. | 6. | 7. | 8. | 9. | 10. | 11. | 12. |
|---------------|----------|-----------|-----------|------------|----------|----------|-----------|-----------|----------|----------|------------|
| FR6 | 2 | R1 | 30 | G15 | C | B | B6 | 00 | 1 | B | MPB |
| SPARE ELEMENT | | R1 | 30 | G15 | C | | | | | | |

| | | |
|--|-------------|---|
| 1. FILTER SERIES | FR6 | |
| 2. TANK MOUNTING HOLES | 2 | 2 holes |
| | 4 | 4 holes |
| | 6 | 2 + 4 holes (for size 20-22-30-31) |
| 3. FILTER ELEMENT SERIES | R1 | |
| 4. FILTER SIZE | 01-02-04 | (available for 2 and 4 holes version only) |
| | 20-22-30-31 | |
| 5. FILTER MEDIA | G06 | glassfiber $\beta_{7\mu\text{m(c)}} > 1.000$ |
| | G10 | glassfiber $\beta_{12\mu\text{m(c)}} > 1.000$ |
| | G15 | glassfiber $\beta_{17\mu\text{m(c)}} > 1.000$ |
| | G25 | glassfiber $\beta_{22\mu\text{m(c)}} > 1.000$ |
| | G40 | glassfiber $\beta_{35\mu\text{m(c)}} > 1.000$ |
| | C10 | paper $\beta_{10\mu\text{m(c)}} > 2$ |
| | T60 | wire mesh 60 μm |
| | M05 | synthetic $\beta_{10\mu\text{m(c)}} > 1.000$ |
| | M10 | synthetic $\beta_{15\mu\text{m(c)}} > 1.000$ |
| 6. BYPASS VALVE | B | 1,7 bar (for paper and wire mesh elements) |
| | C | 3 bar (for glassfiber elements) |
| 7. SEALS | B | NBR |
| 8. MAIN PORT | B4 | G 3/4" (for size 01-02-04) |
| | B5 | G 1" (for size 20-22-30-31) |
| | B6 | G 1 1/4" |
| 9. ADDITIONAL PORTS | 00 | no additional port |
| | B3 | 2 x G 1/2 (for size 01-02-04) |
| | B5 | 2 x G 1 (for size 20-22-30-31) |
| 10. INBUILT AIR BREATHER | 0 | no air breather |
| | 1 | with air breather (not for FR66) |
| 11. INDICATOR PORTS | B | 2 x G 1/8" |
| 12. CLOGGING INDICATORS | 000 | without indicator |
| | MPB | pressure gauge (for "B" bypass) |
| | MPC | pressure gauge (for "C" bypass) |
| | PDB | pressure switch (for "B" bypass) |
| | PDC | pressure switch (for "C" bypass) |
| ACCESSORIES | LC24 | LED connector for pressure switch |
| The accessories must be ordered separately | DS350 | dipstick (not available for 2 holes version) |
| | ET0250 | extension tube 250 mm long (for size 01-02-04) |
| | ET0500 | extension tube 500 mm long |
| | ET2250 | extension tube 250 mm long |
| | ET2500 | extension tube 500 mm long (for size 20-22-30-31) |
| | CT2250 | connection tube 250 mm long |
| | DF040 | diffuser \varnothing 40 mm |
| | B610F03 | spare air breather |

PRESSURE DROP (Δp) INFORMATION FOR FILTER SIZING

The total Delta P through a filter assembly is given from Housing Δp + Element Δp .

The max recommended total Δp for return filters is 0,4 – 0,6 bar with clean element.

For multiport versions, the housing Δp to be considered is the sum of the Δp through all the ports that can be used contemporarily.

N.B. All the reported data have been obtained at our laboratory, according to specification ISO3968 with mineral oil having 32 cSt viscosity at 40°C and density 0,875 kg/dm³.

HOUSING PRESSURE DROP

The housing Δp is given by the curve of the considered model and port, in correspondence of the flow rate value.

FR6x R101-02-04

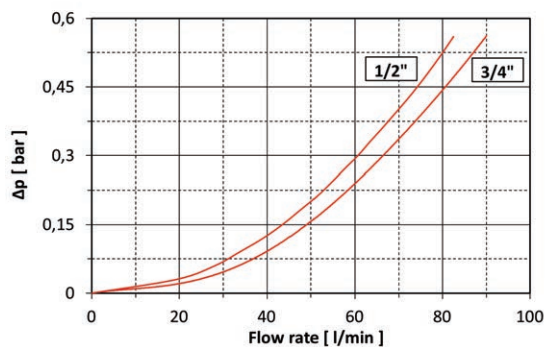

FR6x R120-22

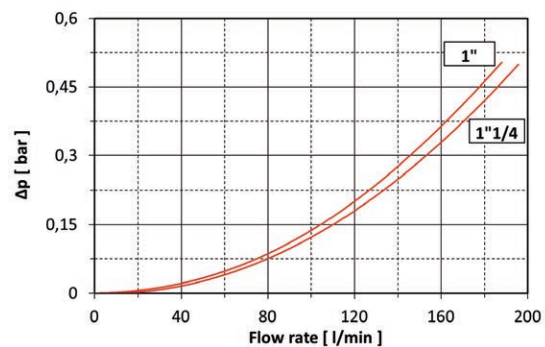

FR6x R130-31

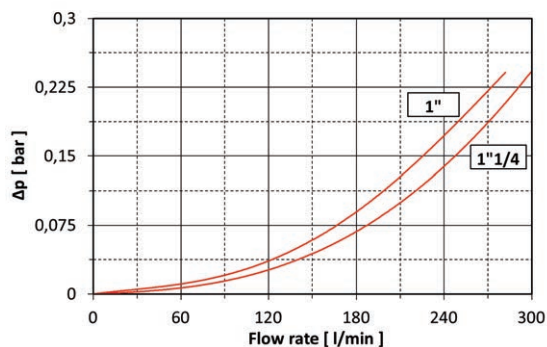

ELEMENT PRESSURE DROP

The element Δp (bar) is given by the flow rate (l/min) multiplied by the factor in the table here below corresponding to the selected media and divided by 1000.

If the oil has a viscosity V_1 different than 32 cSt a corrective factor $V_1/32$ must be applied.

Example: 80 l/min with R130G10B and oil viscosity 46 cSt $> 80 \times 3,19/1000 \times 46/32 = 0,36$ bar

| | G06 | G10 | G15 | G25 | G40 | C10 | T60 | M05 | M10 | M15 |
|-------------|-------|-------|-------|------|------|------|------|------|------|------|
| R101 | 26,84 | 15,20 | 10,04 | 8,37 | 4,32 | 4,59 | 2,43 | 9,94 | 8,49 | 5,30 |
| R102 | 13,16 | 8,22 | 4,94 | 4,55 | 2,63 | 2,88 | 0,82 | 5,37 | 4,59 | 3,03 |
| R104 | 10,96 | 6,41 | 4,00 | 3,82 | 2,02 | 2,45 | 0,79 | 4,27 | 3,65 | 1,79 |
| R120 | 13,85 | 8,65 | 6,44 | 6,32 | 2,77 | 4,09 | 0,86 | 5,65 | 4,83 | 3,19 |
| R122 | 7,80 | 5,27 | 3,92 | 3,60 | 1,55 | 2,70 | 0,76 | 3,83 | 3,27 | 1,79 |
| R130 | 5,09 | 3,19 | 2,25 | 2,06 | 0,90 | 1,64 | 0,49 | 2,31 | 1,98 | 1,02 |
| R131 | 3,34 | 1,94 | 1,37 | 1,26 | 0,46 | 1,06 | 0,24 | 1,41 | 1,20 | 0,63 |

EXAMPLE OF TOTAL Δp CALCULATION

FR62R130G10BBB6001B000 with **80** l/min and oil **46** cSt:

Housing Δp 0,01 bar + element Δp 0,36 bar ($80 \times 3,19/1000 \times 46/32$) = total assembly Δp 0,37 bar

BYPASS VALVE PRESSURE DROP

The bypass valve Δp is given by the curve of the considered model and setting, in correspondence of the flow rate value.

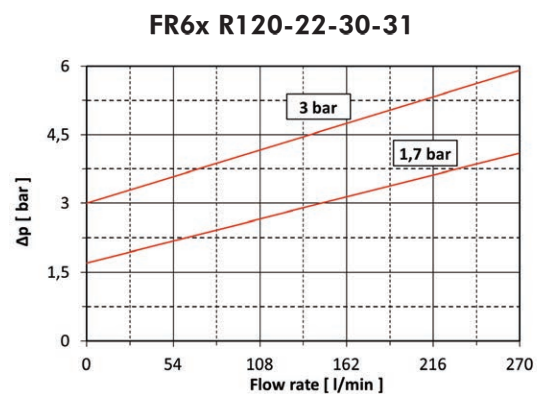
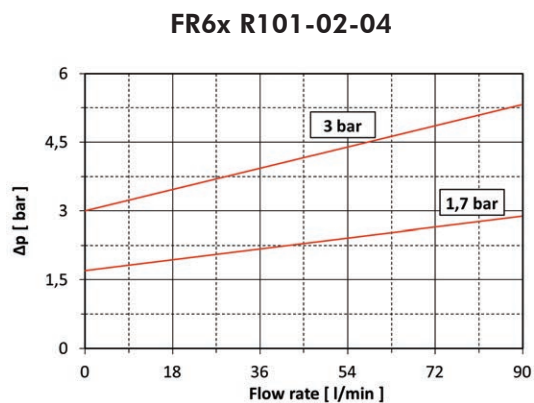

ACCESSORIES

These accessories fit all our standard models and must be ordered separately.

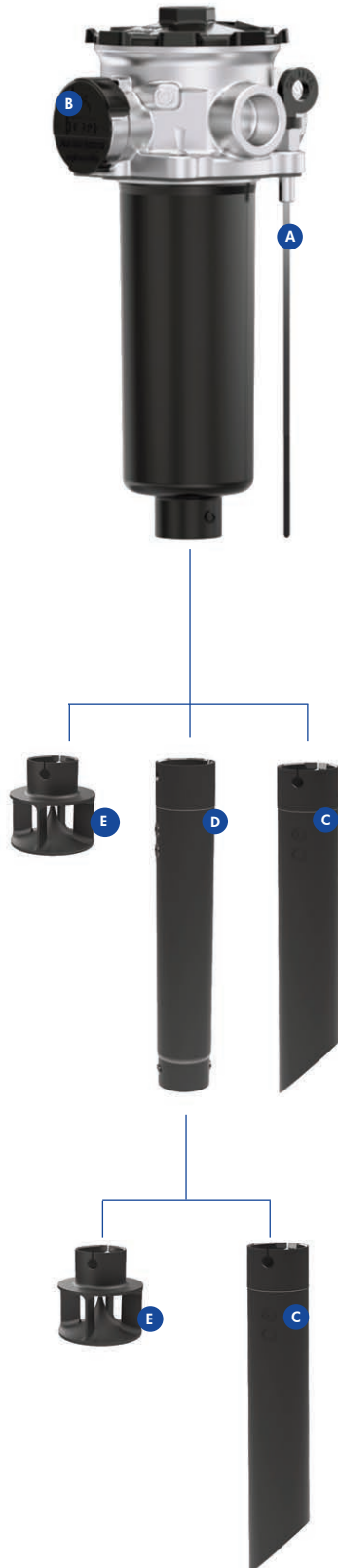

A * DIPSTICK for oil level detection

When reduced space available, one of the tank fixing hole can be used for a dipstick to check the oil level; it is supplied with a M10 bolt support.

* not available for 2 holes version

| | |
|-------|----------------------|
| DS350 | dipstick 350 mm long |
|-------|----------------------|

B AIR BREATHER

| PART NR. | FILTRATION | FLOW RATE | Δp |
|----------|------------|------------------|------------|
| B610F03 | 3 μm | up to 300 NI/min | 50 mbar |

N.B. we recommend to replace the air breather when replacing the oil filter element.

(when working in a very dirt environment, a more frequent air breather replacement could be necessary)

C EXTENSION TUBE

The flow from the filter must come out below the oil level to avoid possible generation of free air or foam.

When necessary an extension tube can be fitted onto the knobs of the bowl end.

for size 01-02-04

| | |
|--------|----------------------------|
| ET0250 | extension tube 250 mm long |
| ET0500 | extension tube 500 mm long |

for size 20-22-30-31

| | |
|--------|----------------------------|
| ET2250 | extension tube 250 mm long |
| ET2500 | extension tube 500 mm long |

D CONNECTION TUBE

Connection tube is the necessary device between filter bowl and extension tubes (ET2250/ET2550) and/or diffuser (DF040). Its plug and play option makes it easy to install and versatile.

for size 20-22-30-31

| | |
|--------|-----------------------------|
| CT2250 | connection tube 250 mm long |
|--------|-----------------------------|

E DIFFUSER

Diffuser is an effective way to reduce foaming and turbulence normally caused by return lines. Plug and play option to be directly installed on the filter bowl or to connection tube (CT2250). Installation of a diffuser in the hydraulic tank is an easy way to ensure the reliability of the overall system.

Diffuser must always be installed below the minimum oil level.

for size 20-22-30-31

| | |
|-------|------------------------------|
| DF040 | diffuser \varnothing 40 mm |
|-------|------------------------------|

USER TIPS



- 1 COVER
- 2 SPRING
- 3 SEAL KIT
- 4 FILTER ELEMENT
- 5 FILTER BOWL
- 6 FILTER HEAD
- 7 AIR BREATHER

SPARE SEALS KIT (3)

| | NBR |
|----------------|--------------|
| FR6-2-R1-0x | 06.021.00256 |
| FR6-4-R1-0x | 06.021.00257 |
| FR6-2-R1-2x/3x | 06.021.00258 |
| FR6-4-R1-2x/3x | 06.021.00259 |
| FR6-6-R1-2x/3x | 06.021.00260 |

COVER TIGHTENING TORQUE

20 Nm

INDICATOR TIGHTENING TORQUE

10 Nm

WARNING

-  Make sure that Personal Protective Equipment (PPE) is worn during installation and maintenance operation.

DISPOSAL OF FILTER ELEMENT

-  The used filter elements and the filter parts dirty of oil are classified as "Dangerous waste material": they must be disposed according to the local laws by authorized Companies.



INSTALLATION

1. The gasket (7) must be properly positioned and the head (6) well secured on the tank lid through the fixing holes.
2. The hose must be properly connected to the IN port.
-  3. The OUT port must be clear (an extension tube could be fitted, if needed for having the outlet below the oil level).
4. Verify that no tension is present on the filter after mounting.
5. When present the air breather (8), it must be in a protected position.
6. Enough space must be available for filter element replacement.
7. The visual clogging indicator must be in a easily viewable position.
8. When a electrical indicator is used, make sure that it is properly wired.
9. Keep in stock a spare FILTREC filter element for timely replacement when required.
10. Filter housing should be earthed.

OPERATION

-  1. The filter must work within the operating conditions of pressure, temperature and compatibility given in the first page of this data sheet.
2. The filter element must be replaced as soon as the clogging indicator signals at working temperature (in cold start conditions, oil temperature lower than 30°C, a false alarm can be given due to oil viscosity).
3. If no clogging indicator is mounted, replace the element according to the system manufacturer's recommendations.

MAINTENANCE

-  1. Before removing the cover (1), ensure that the system is switched off and there is no residual pressure in the filter.
2. Unscrew the cover (1) by turning it anti-clockwise and remove it.
3. Remove the spring (2) first, then the dirty element (4) and the bowl (5).
4. Clean the bowl (5) and fit a new FILTREC element (4), verifying the part number, particularly concerning the micron rating.
5. When fitting the new element (4), open its plastic protection on the open end side and insert it onto the spigot in the filter bowl, then remove completely the plastic protection.
6. Check the O-ring (3) conditions and replace if necessary.
7. Put the spring (2) in its position on the filter element.
8. Screw the cover (1) by turning it clockwise, tighten at the recommended torque.
-  9. The used filter elements cannot be cleaned and re-used.

For more information:

WEB: FLTR.com.au PHONE: (+61) 1300 62 4020 EMAIL: info@FLTR.com.au