



FT5 & FT8 SERIES

Filler breathers with flange or welding mounting

These filler breathers, manually tightened on the tank, are suggested for prevent from the solid contamination contained in the air applications and during the loading and the emptying of the tank.



TECHNICAL SPECIFICATION

MATERIALS:	Cover: chrome plated steel
	Basket: zinc plated steel
	Flange: zinc plated steel
	Gaskets: NBR
FILTER MEDIA:	Polyurethane (air filtration 3 μm e 10 μm)
PRESSURIZATION VALVE:	0.35 or 0.75 bar (for FT8 only)
TEMPERATURE RANGE:	-30° C to +100° C
FLUID COMPATIBILITY:	Full with HH-HL-HM-HV HETG-HEES (acc. to ISO 6743/4). For use with other fluid please contact Filtrec Customer Service (info@filtrec.it).

HYDRAULIC SYMBOL

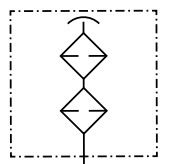

AIR BREATHING SIZING

Air Breathers play a crucial role as part of a hydraulic system's filtration mechanism. The amount of dust retained by an Air Breather depends on various factors, such as the average air dust concentration and the air flow passing through the breather in NI/min. The following table illustrates the typical average air dust concentrations found in real-life environments. Notably, these concentrations can vary significantly, thus impacting the service life of the Air Breather.

DUST CONCENTRATION (depends on application and environment)	$K_{op.cond}$
High level	7 ÷ 10
Medium level	3 ÷ 7
Low level	1 ÷ 3

Measuring the air flow poses a challenging task. Typically, this parameter can be estimated using the following equation:

$$Q_{air\ flow} = K_{op.cond} \times Q$$

Here, Q represents the flow rate of the hydraulic pump in l/min, and $K_{op.cond}$ is a multiplicative factor associated with the operating conditions. For instance, in ambient conditions with low dust concentration, $K_{op.cond}$ may range between 1 and 2, while in environments with high dust concentration, it could be in the range of 7 to 10. It is important to note that $K_{op.cond}$ is subject to substantial variability, which, in turn, introduces uncertainty in the service life of the Air Breather.



Filtrec's Air Breathers serve as a fundamental element in every hydraulic system.

It is essential to bear in mind that removing particles from a hydraulic system incurs significantly higher costs compared to excluding them in the first place.

Given this undeniable truth, it becomes evident that the advantages of utilizing our high-quality air breathers are substantial.

We highly recommend replacing the air breather with each service interval (or, at the very least, annually), matching the frequency of replacing the return fluid filters. Doing so ensures optimal performance and longevity of the hydraulic system.

OVERALL DIMENSIONS

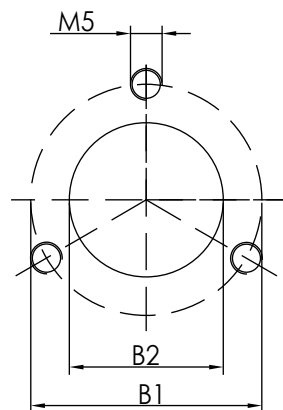
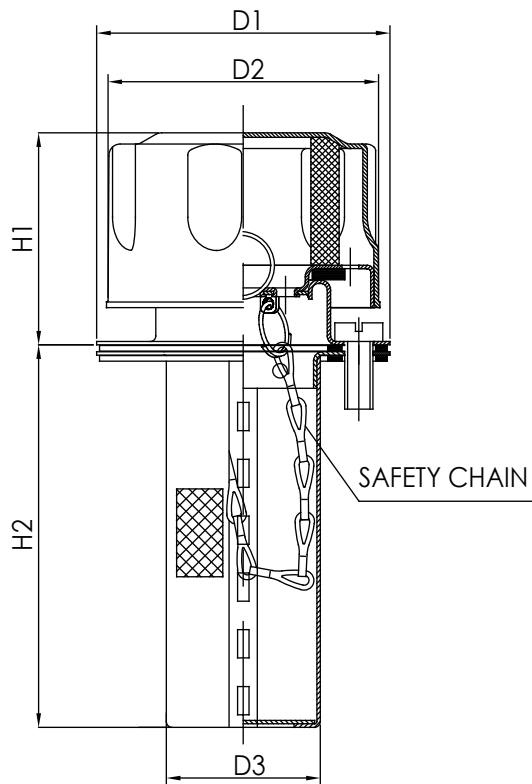

NOMINAL SIZE

CODE	B1	B2	H1	H2	D1	D2	D3	AIR FLOW RATE NI/min Dp 0,015 barg	
								F03	F10
FT5	41	31	37	67	52	48	27,5	200	250

ORDERING INFORMATION

1.	2.	3.	4.	5.	6.
FT	5	F03	B	0	0

1. SERIES	FT	
2. FILTER SIZE	5	cover Ø48
3. FILTER MEDIA	F03	polyurethane (air filtration 3 µm)
	F10	polyurethane (air filtration 10 µm)
4. GASKETS	B	NBR
5. PRESSURIZATION VALVE	0	no valve
6. PADLOCK HOLDER	0	without padlock holder

OVERALL DIMENSIONS FT8

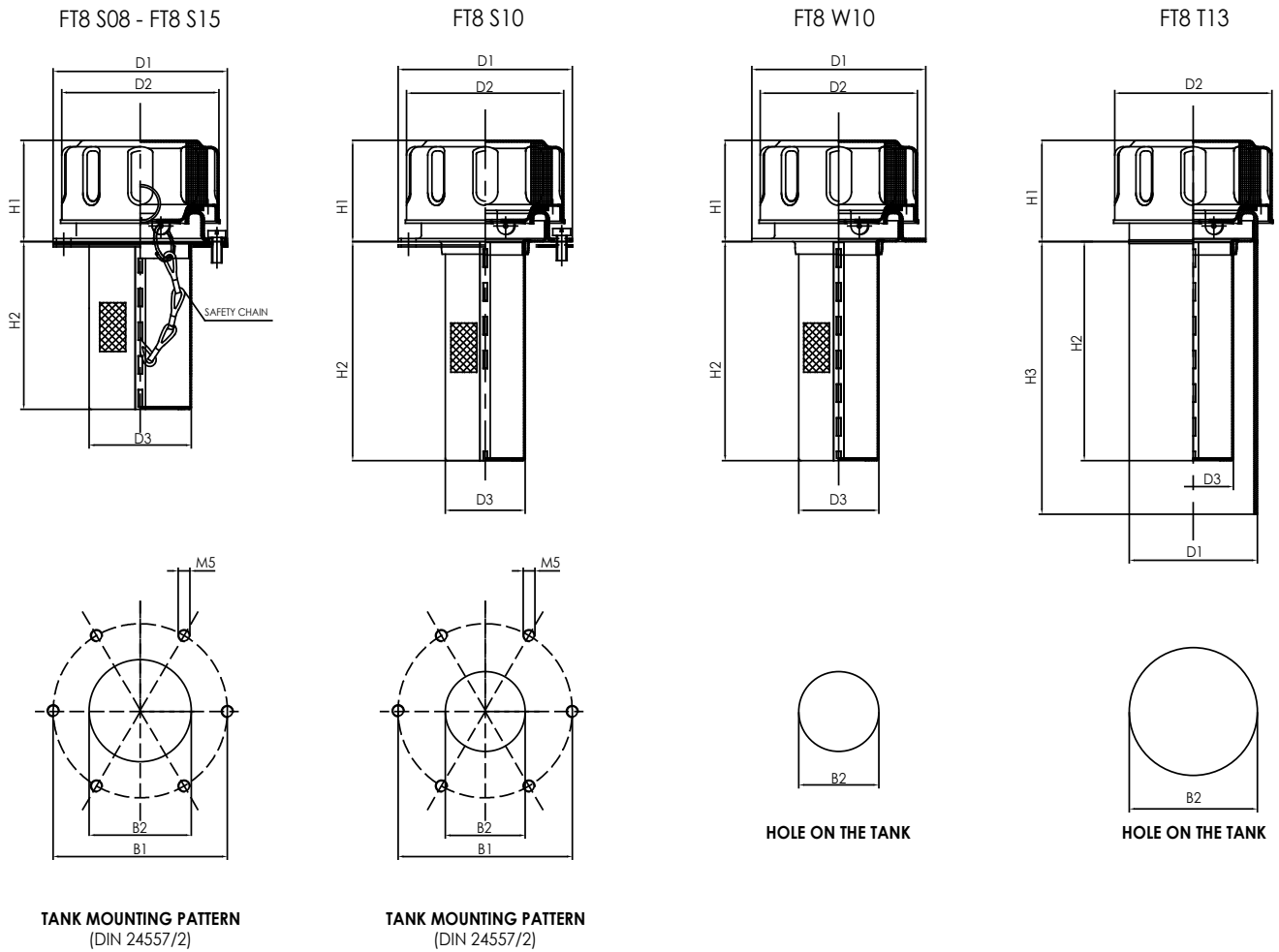

NOMINAL SIZE

CODE	B1	B2	H1	H2	D1	D2	D3	AIR FLOW RATE NI/min Dp 0,015 barg	
								F03	F10
FT8 S8		52	50	80	83	75	50	450	550
FT8 S15	71 ÷ 73			150					
FT8 S10		40		105			38		

CODE	B1	B2	H1	H2	D1	D2	D3	AIR FLOW RATE NI/min Dp 0,015 barg	
								F03	F10
FT8 W10	40	50	105	-	83	75	38	200	250
FT8 T13	62			130	60			450	550

ORDERING INFORMATION

1.	2.	3.	4.	5.	6.	7.
FT	8	F03	B	S08	0	L

1. SERIES	FT	
2. FILTER SIZE	8	cover Ø75
3. FILTER MEDIA	F03	polyurethane (air filtration 3 µm)
	F10	polyurethane (air filtration 10 µm)
4. GASKETS	B	NBR
5. MOUNTING TYPE	S08	flange, basket h = 80 mm
	S15	flange, basket h = 150 mm
	S10	flange, removable basket
	W10	welding flange
	T13	with antisplash tube
6. PRESSURIZATION VALVE	0	no pressurization valve
	1	0,35 bar
	2	0,75 bar
7. PADLOCK HOLDER	0	without padlock holder
	L	with padlock holder

ACCESSORIES

The accessories must be ordered separately

06.016.00548	BS125 Spacer support
--------------	----------------------



**SPACER SUPPORT
BS125**

When the oil tank can be subjected to strong shocks or oscillations, the optional spacer support (BS125) prevents oil splashes from escaping and wetting the filter element.

USER TIPS



- 1 CAP
- 2 SCREWS
- 3 FLANGE
- 4 GASKET
- 5 BASKET

WARNING

-  Make sure that Personal Protective Equipment (PPE) is worn during installation and maintenance operation.

DISPOSAL OF FILTER ELEMENT

-  The used filter elements and the filter parts dirty of oil are classified as "Dangerous waste material": they must be disposed according to the local laws by authorized Companies.

INSTALLATION

1. Place the gasket (4) between the flange (3) and the tank.
2. Connect gasket and fixing flange to the tank using the screws (2).
3. Fit the basket (5) and screw the cap (1) until it is locked.

MAINTENANCE

-  1. Before removing the filler breather, ensure that the system is switched off and there is no residual pressure in the system.
- 2. Remove the filler breather.
- 3. Fit the new filler breather following installation instruction.

USER TIPS



WARNING

-  Make sure that Personal Protective Equipment (PPE) is worn during installation and maintenance operation.

DISPOSAL OF FILTER ELEMENT

-  The used filter elements and the filter parts dirty of oil are classified as "Dangerous waste material": they must be disposed according to the local laws by authorized Companies.

INSTALLATION

1. Align the flange (2) with the hole on tank, paying attention to the axial alignment.
2. Weld the flange (2) to the tank.
3. Fit the basket (3) and screw the cap (1) until it is locked.

MAINTENANCE

-  1. Before removing the filler breather, ensure that the system is switched off and there is no residual pressure in the system.
- 2. Remove the filler breather.
- 3. Fit the new filler breather following installation instruction.