



## FT6 & FT7 SERIES

Air breather filters

These air breather filters, manually tightened, are suggested for applications on hydraulic power unit or tanks subjected to rapid volume changes, where high air flows are involved.



### TECHNICAL SPECIFICATION

MATERIALS:	Cover: chrome plated steel Threaded connection: zinc plated steel
FILTER MEDIA:	Polyurethane (air filtration 3 $\mu\text{m}$ e 10 $\mu\text{m}$ )
PRESSURIZATION VALVE:	0.35 or 0.75 bar (for FT7 only)
TEMPERATURE RANGE:	-30° C to +100° C
FLUID COMPATIBILITY:	Full with HH-HL-HM-HV HETG-HEES (acc. to ISO 6743/4). For use with other fluid please contact Filtrec Customer Service (info@filtrec.it).

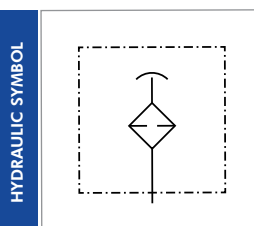

## AIR BREATHER SIZING

Air Breathers play a crucial role as part of a hydraulic system's filtration mechanism. The amount of dust retained by an Air Breather depends on various factors, such as the average air dust concentration and the air flow passing through the breather in NI/min. The following table illustrates the typical average air dust concentrations found in real-life environments. Notably, these concentrations can vary significantly, thus impacting the service life of the Air Breather.

DUST CONCENTRATION (depends on application and environment)	$K_{op.cond}$
High level	7 ÷ 10
Medium level	3 ÷ 7
Low level	1 ÷ 3

Measuring the air flow poses a challenging task. Typically, this parameter can be estimated using the following equation:

$$Q_{air\ flow} = K_{op.cond} \times Q$$

Here,  $Q$  represents the flow rate of the hydraulic pump in l/min, and  $K_{op.cond}$  is a multiplicative factor associated with the operating conditions. For instance, in ambient conditions with low dust concentration,  $K_{op.cond}$  may range between 1 and 2, while in environments with high dust concentration, it could be in the range of 7 to 10. It is important to note that  $K_{op.cond}$  is subject to substantial variability, which, in turn, introduces uncertainty in the service life of the Air Breather.



**Filtrec's Air Breathers serve as a fundamental element in every hydraulic system.**

It is essential to bear in mind that removing particles from a hydraulic system incurs significantly higher costs compared to excluding them in the first place.

Given this undeniable truth, it becomes evident that the advantages of utilizing our high-quality air breathers are substantial.

**We highly recommend replacing the air breather with each service interval** (or, at the very least, annually), matching the frequency of replacing the return fluid filters. Doing so ensures optimal performance and longevity of the hydraulic system.

## OVERALL DIMENSIONS

---

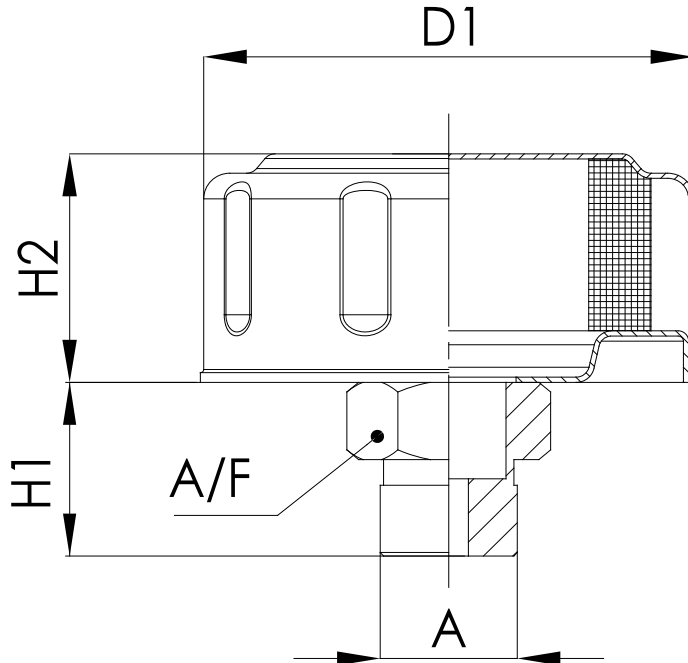

## NOMINAL SIZE

---

CODE	A	H1	H2	D1	A/F	AIR FLOW RATE NI/min Dp 0,015 barg	
						F03	F10
FT6...B1	G 1/4"	27	31	48	22	200	250
FT6...B2	G 3/8"						
FT6...B3	G 1/2"						
FT7...B3	G 1/2"	27	35,5	75	27	450	550
FT7...B4	G 3/4"						

## ORDERING INFORMATION

1.	2.	3.	4.	5.
<b>FT</b>	<b>7</b>	<b>F03</b>	<b>B4</b>	<b>1</b>

1. SERIES	FT	
2. FILTER SIZE	6	cover Ø48
	7	cover Ø75
3. FILTER MEDIA	F03	polyurethane (air filtration 3 µm)
	F10	polyurethane (air filtration 10 µm)
4. CONNECTIONS	B1	G 1/4" — FT6
	B2	G 3/8" — FT6
	B3	G 1/2" — FT6 - FT7
	B4	G 3/4" — FT6 - FT7
5. PRESSURIZATION VALVE	0	no valve
	1	0,35 bar — FT7 only
	2	0,75 bar — FT7 only

## USER TIPS

---



1 MALE THREAD

## WARNING

---

-  Make sure that Personal Protective Equipment (PPE) is worn during installation and maintenance operation.

## DISPOSAL OF FILTER ELEMENT

---

-  The used filter elements and the filter parts dirty of oil are classified as "Dangerous waste material": they must be disposed according to the local laws by authorized Companies.

## INSTALLATION

---

1. The air breather filters are mounted on the tank in a threaded seat (no burrs, sharp edges or dirt is admitted on the seat).
2. Add some lubricant on the male thread (1) and tighten until stop.
3. Refer to the tank manufacturer specifications for tighten torque.

## MAINTENANCE

---

-  1. Before removing the filler breather, ensure that the system is switched off and there is no residual pressure in the system.
- 2. Remove the filler breather.
- 3. Fit the new filler breather following installation instruction.