



FUVR050 SERIES

Portable off-line filtration unit specific for reducing or eliminating the presence of varnish in hydraulic and lubrication systems.
Without chiller



TECHNICAL SPECIFICATION

MAIN:	Flow Rate: 50 l/min Operating temperature: from 0 °C to + 80°C Fluid viscosity range: 10-800cSt
ELECTRIC:	Voltage: 380/400 Vac 220/230 Vac (on request) Frequency: 50 - 60 Hz Power consumption: 1,5Kw
FRAME:	Dimensions L, W, H[mm]: 730X950X1320
DRY WEIGHT:	155 Kg
MATERIALS:	Base frame: Painted steel

ELEMENT

tested according to ISO 11170, 2941, 2942, 2943, 3724, 3968, 16889, 16908, 23181

VARNISH REMOVAL:	U564G01/VRE U564GW01/VRE
-------------------------	-----------------------------

FLUID COMPATIBILITY:	Full with HH-HL-HM-HV HETG-HEES (acc. to ISO 6743/4). For use with other fluid please contact Filtrec Customer Service (info@filtrec.it).
-----------------------------	---

The unit is supplied complete with an Instruction and Maintenance Manual available on our website www.filtrec.com in the "Hydraulic Filter" section. The unit can be used by authorized operators who have read and understood all of its contents.

The FUVR050 filtration units are certified

For more information:

WEB: FLTR.com.au PHONE: (+61) 1300 62 4020 EMAIL: info@FLTR.com.au

WHAT IS VARNISH



During the normal use of a hydraulic system, the lubricating or the hydraulic fluid can separate insoluble substances due to thermo-oxidative degradation of the fluid itself.

Different phenomena can lead to the separation of these substances:

- thermal degradation due to the presence of hot spots ($T > 100^{\circ}\text{C}$) and electrostatic discharge
- hydrolysis and oxidation due to the presence of air, water and solid contamination that works as catalyst
- micro-dieseling due to cavitation

These substances are called "varnish precursors".

When they settle down on the surfaces of hydraulic system components, they form a thin, insoluble and sticky layer called "varnish".

Varnish has detrimental effects on the operating properties of the hydraulic components like bearings, servo-valves, pumps etc.

For example, on servo-valves, varnish can lead to incorrect and unstable response, jamming of the spool and burnout of the solenoid.

CAN WE CHECK THE PRESENCE OF VARNISH PRECURSORS IN THE FLUID?

Using the colorimetric analysis described in ASTM D7843-21 standard, it is possible to measure the varnish potential of the fluid.

According to the analysis procedure, 50 ml of sample mixed with 50 ml of petroleum ether are filtered under vacuum on a $0.45\ \mu\text{m}$, mixed esters of cellulose, analysis membrane.

The analysis membrane is then analyzed using a spectrophotometer and compared with a brand-new membrane. Results are reported according to CIE Lab scale and ΔE^* value, which represents the varnish potential of the fluid is calculated.

ΔE^* values lower than 25 are considered acceptable, however it is suggested to monitor the varnish potential with periodical analysis.

If ΔE^* value increases, it is necessary to remove the varnish precursor from the oil to avoid any future problem.

CAN WE REMOVE VARNISH PRECURSORS FROM THE FLUID?

Using dedicated filtration media and a low flow rate it is possible to remove varnish precursors from hydraulic and lubricating fluid.

Filtrec filter elements with "/VRE" option are able to efficiently remove non-solid substances like varnish precursors as well as solid particle contamination.

These filter elements combine a high efficiency glass fiber media ($\beta_{4(c)} \geq 2000$) and a dedicated cellulose fibers media to reach high filtration performance for solid and non-solid contaminants.

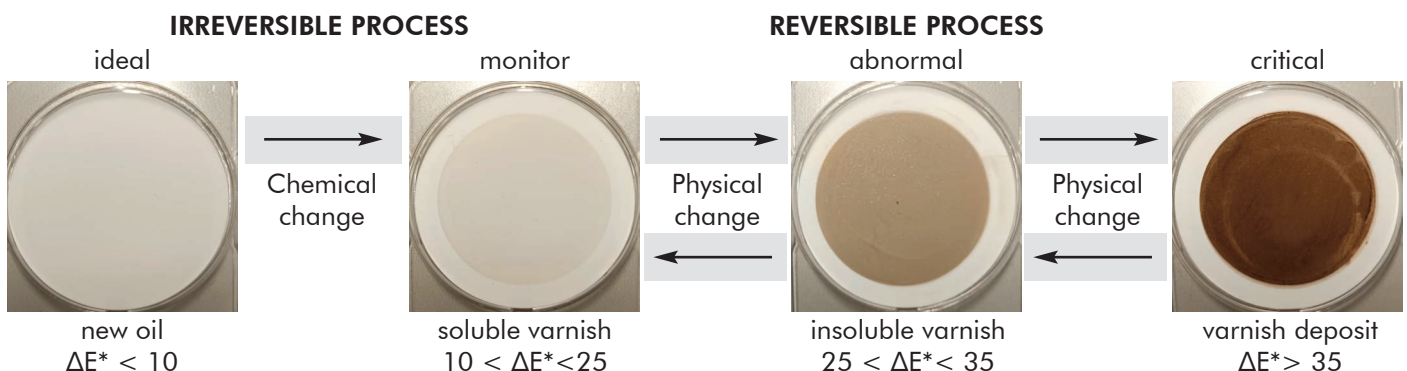

For more information:

WEB: FLTR.com.au PHONE: (+61) 1300 62 4020 EMAIL: info@FLTR.com.au

OVERALL DIMENSIONS

FUVR050

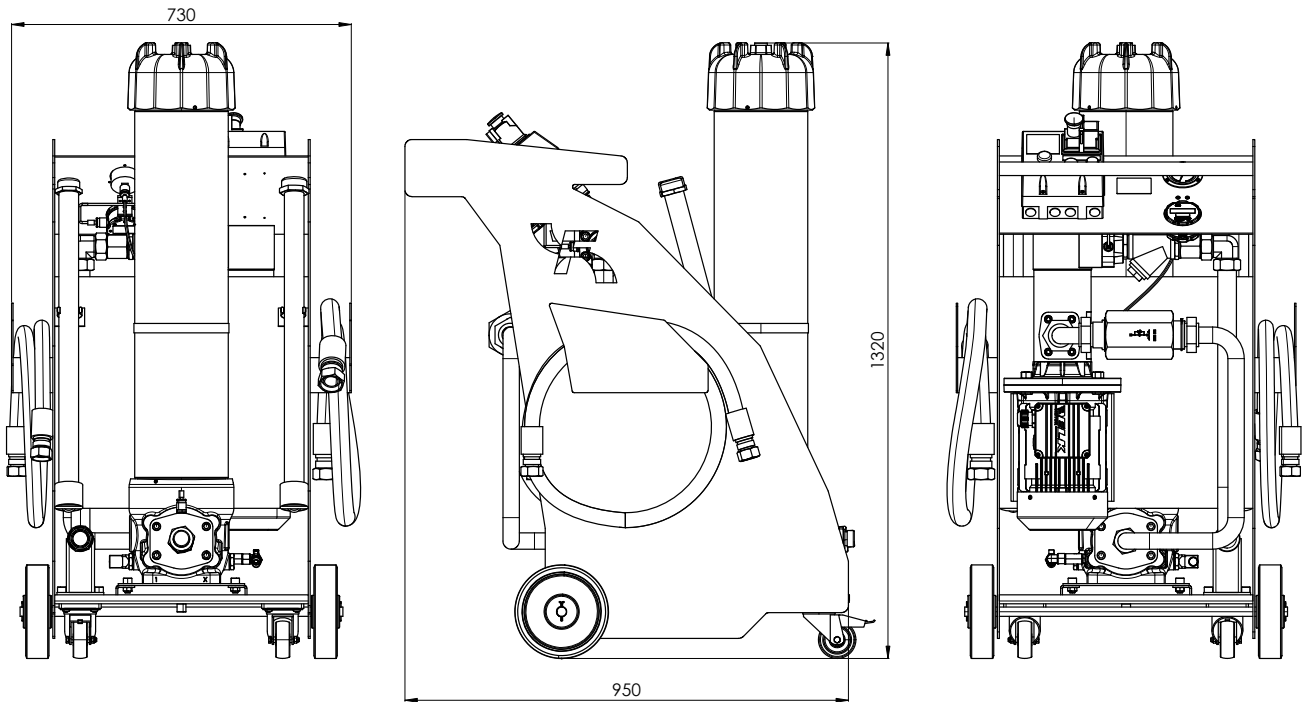

HYDRAULIC DIAGRAM

FUVR050

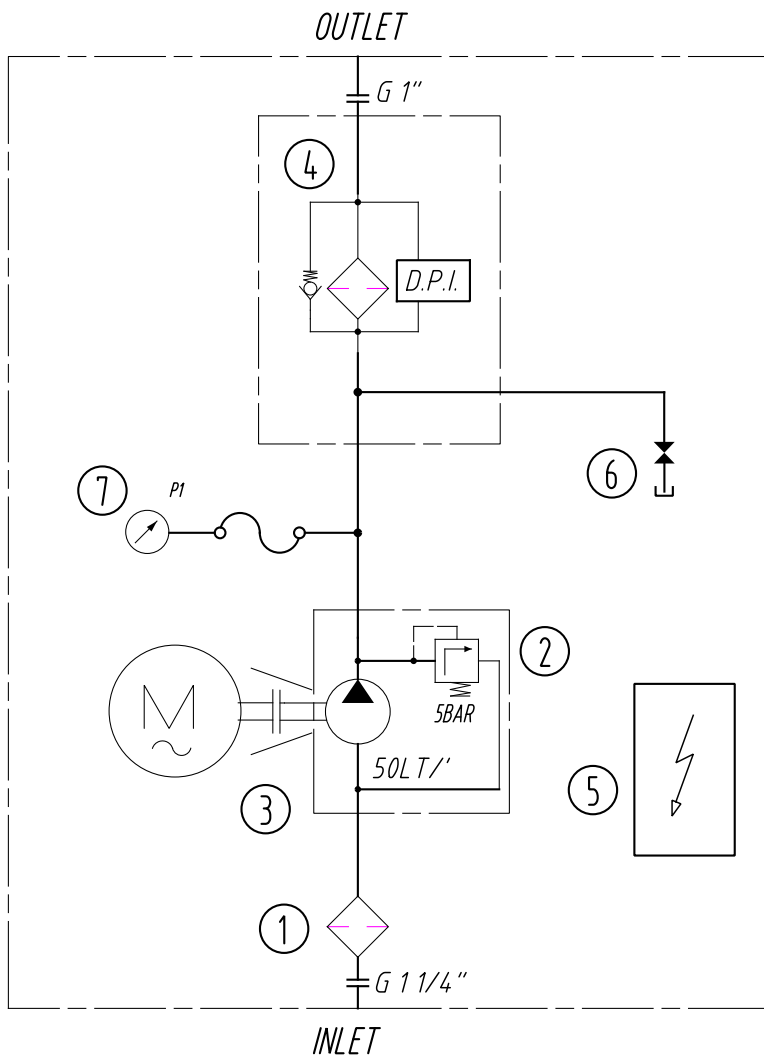

- 1- Suction filter "Y" 500 μ m
- 2- Gear pump + pressure relief valve 5 bar
- 3- Motor with pump coupling
- 4- Filter with visual clogging indicator
- 5- Control Panel
- 6- Sampling drain valve
- 7- Pressure gauge

Suction and delivery hoses are included but not connected

ORDERING INFORMATION

FUVR050

1.	2.	3.	4.	5.	6.	7.	8.
FUVR	050	T	G	4	B	S	0

1. FILTER UNIT	FUVR	
2. MODEL	050	flow rate 50 l/min
3. ELECTRIC MOTOR	T	three phase electric motor, 380/400 Vac 50-60 Hz, 1,5 Kw
	M	single phase electric motor, 220/230 Vac 50-60 Hz, 1,5 Kw (on request)
4. PUMP SIZE	G	gear pump with + pressure relief valve 5 bar
5. FILTER / ELEMENT SIZE	4	1 x U564 series
6. SEAL	B	NBR
7. VERSION	S	standard version
8. OPTION	0	With visual clogging indicator, differential indicator model VX2 Support frame with drip tray Suction filter "Y" 500 µm Suction and delivery hoses + lance L=3m 3P+N+PE (N=not connected)+ industrial plug, L=2m Control panel with ON/OFF switch with safety release coil and emergency interlock push button

ORDERING INFORMATION SPARE ELEMENTS

1.	2.	3.	4.	5.	6.
U5	64	G01	B	0	/VRE
1. FILTER ELEMENT SERIES	U5				
2. FILTER SIZE	64				
3. FILTER MEDIA	G01	glassfiber $\beta_{4\mu m(c)} > 2.000$			
	GW01	glassfiber $\beta_{4\mu m(c)} > 2.000$ + water absorbent			
4. SEALS	B	NBR			
5. BYPASS VALVE	0	no bypass			
6. OPTION	/VRE	varnish removal element			

USER TIPS

The filter element must be replaced when:

1. the clogging indicator shows ; more filter elements could be necessary to reach acceptable ΔE value < 25 , depending on the oil volume to be cleaned and from the initial contamination level.

The unit is supplied complete with an Instruction and Maintenance Manual available on our website www.filtrec.com in the "Hydraulic Filter" section. The unit can be used by authorized operators who have read and understood all of its contents.

For more information:

WEB: FLTR.com.au PHONE: (+61) 1300 62 4020 EMAIL: info@FLTR.com.au