



FVR7F SERIES

Return filter inserts

Filter inserts for mounting inside the tank on the return line. Filtration from inside to outside.
Flow rates up to 3500 l/min.



HOUSING	tested according to NFPA T3.10.5.1*, ISO 10771*, ISO 3968
PRESSURE:	Max operating: 10 bar
MATERIALS:	Element holder: aluminium alloy Diffuser: stainless steel Seal: NBR (FKM on request)
BYPASS VALVE:	B version 1,7 bar C version 3 bar (not available for FVR7F4x)

ELEMENT	tested according to ISO 11170, 2941, 2942, 2943, 3724, 3968, 16889, 16908, 23181
FILTER MEDIA:	Inorganic microfiber G03 - G06 - G10 - G15 - G25 - G40 Paper: C10 - C25 Wire mesh: T60 Synthetic: M05 - M10 - M15
BURST PRESSURE:	10 bar

TEMPERATURE RANGE:	-30°C +100°C
FLUID COMPATIBILITY:	Full with HH-HL-HM-HV HETG-HEES (acc. to ISO 6743/4). For use with other fluid please contact Filtrec Customer Service

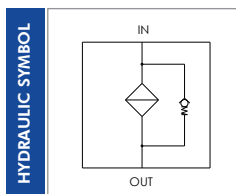

* as reference method only for verifying the pressure fatigue resistance and establishing the burst pressure ratings.

For more information:

WEB: FLTR.com.au PHONE: (+61) 1300 62 4020 EMAIL: info@FLTR.com.au

FV-R7F-1X

VERSION 0

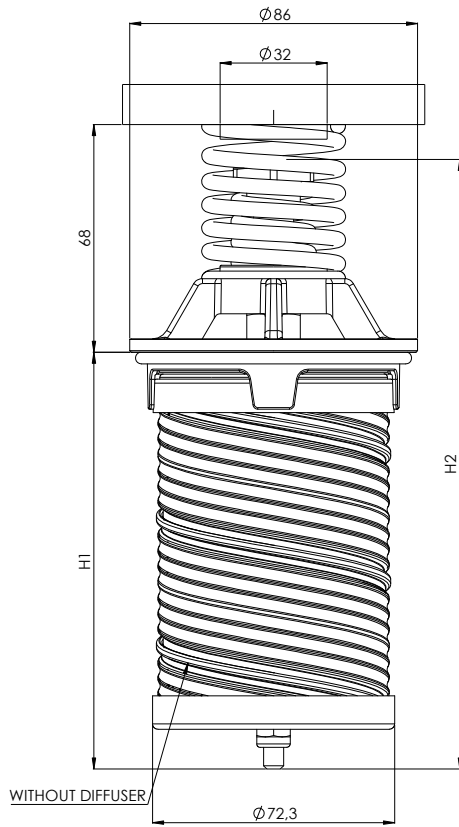

VERSION D

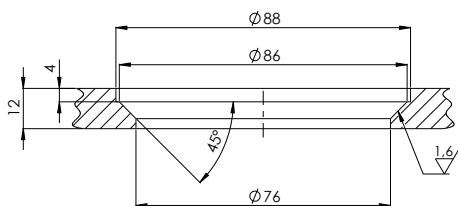
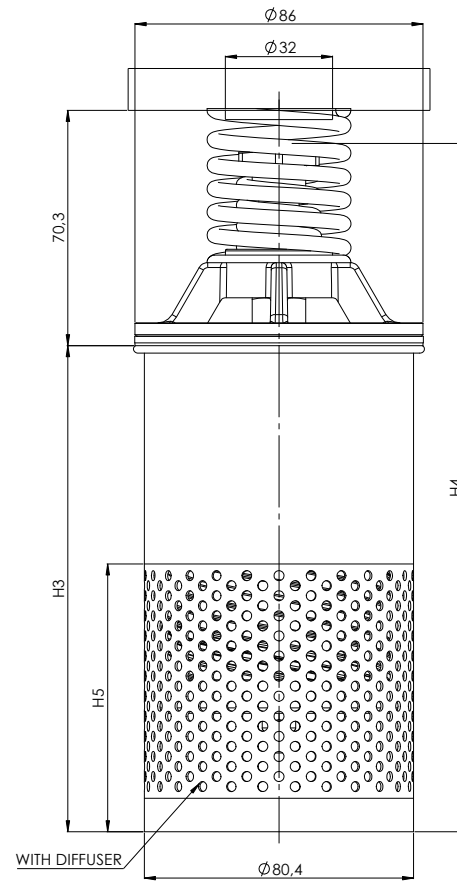

NOMINAL SIZE

MODEL	H1	H2	H3	H4	H5	H6	H7	WEIGHT*	
								Vers. 0	Vers. D
FVR7F-11	124,5	182	145	205,5	80	148	205,5	0,4 Kg	0,6 Kg
FVR7F-12	169,5	227	190	250,5	80	193	250,5	0,4 Kg	0,7 Kg
FVR7F-13	219,5	277	240	300,5	80	243	300,5	0,4 Kg	0,8 Kg
FVR7F-14	319,5	377	340	400,5	100	380	400,5	0,5 Kg	1 Kg

* Weight without element and magnets

For more information:

WEB: FLTR.com.au PHONE: (+61) 1300 62 4020 EMAIL: info@FLTR.com.au

FV-R7F-1X

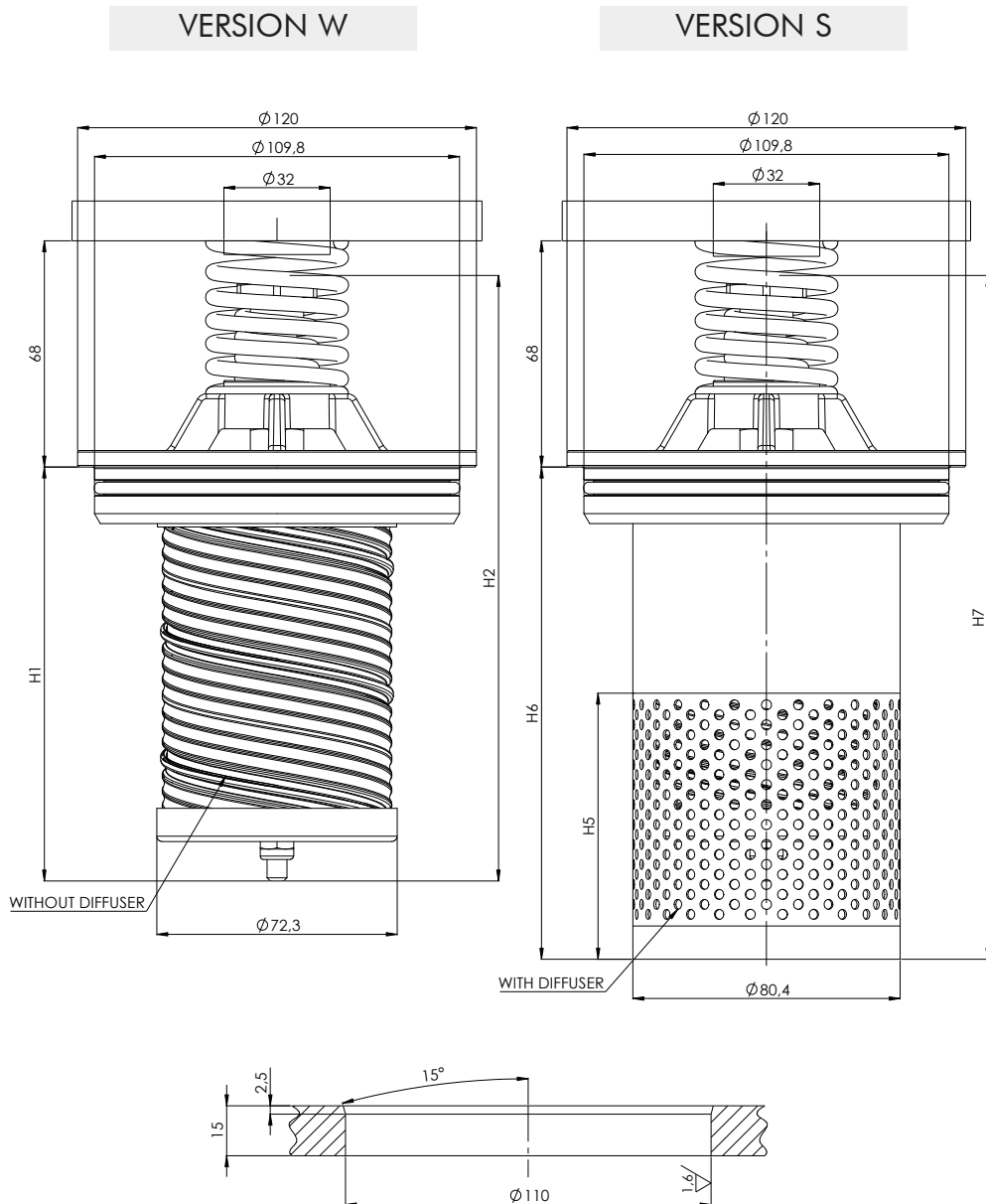

NOMINAL SIZE

MODEL	H1	H2	H3	H4	H5	H6	H7	WEIGHT	
								Vers. W	Vers. S
FVR7F-11	124,5	182	145	205,5	80	148	205,5	0,6Kg	0,9 Kg
FVR7F-12	169,5	227	190	250,5	80	193	250,5	0,7 Kg	1 Kg
FVR7F-13	219,5	277	240	300,5	80	243	300,5	0,7 Kg	1,1 Kg
FVR7F-14	319,5	377	340	400,5	100	380	400,5	0,7 Kg	1,3 Kg

* Weight without element and magnets

For more information:

WEB: FLTR.com.au PHONE: (+61) 1300 62 4020 EMAIL: info@FLTR.com.au

FV-R7F-2

VERSION 0

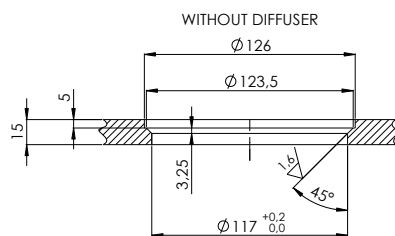
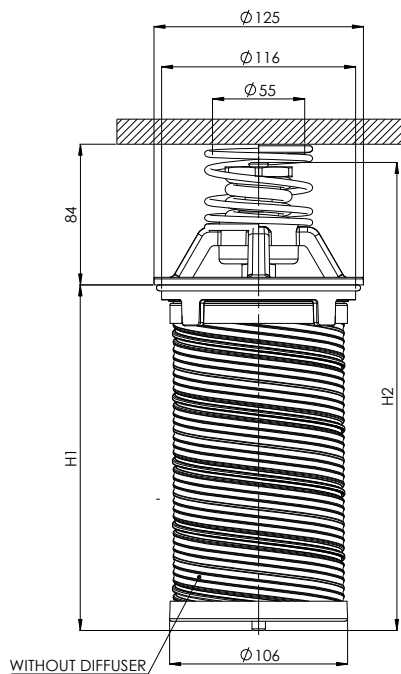

VERSION S

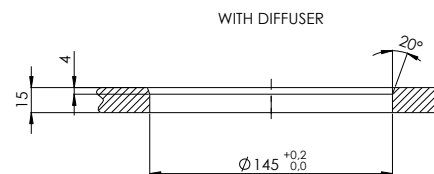
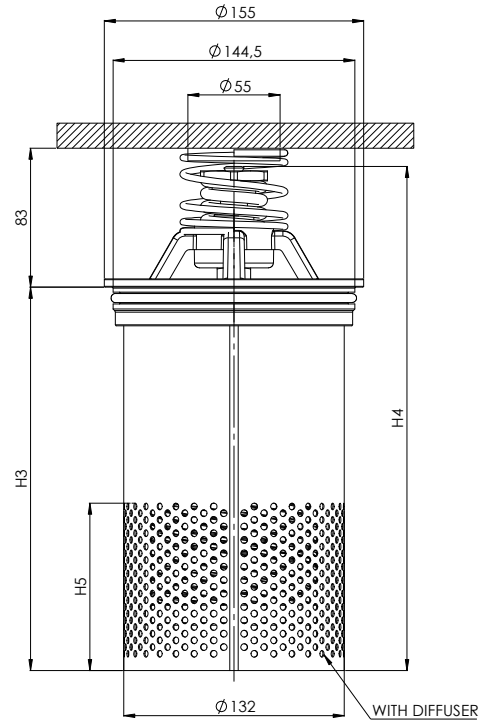

NOMINAL SIZE

MODEL	H1	H2	H3	H4	H5	WEIGHT*	
						Vers. 0	Vers. S
FVR7F-20	206,5	277,5	229	299	100	0,9 Kg	1,5 Kg
FVR7F-21	276,5	347,5	299	369	100	0,9 Kg	1,7 Kg
FVR7F-22	481,5	552,5	504	574	150	1,1 Kg	2,3 Kg
FVR7F-26	536,5	697,5	559	629	150	1,1 Kg	2,5 Kg

* Weight without element and magnets

For more information:

WEB: FLTR.com.au PHONE: (+61) 1300 62 4020 EMAIL: info@FLTR.com.au

FV-R7F-3

VERSION 0

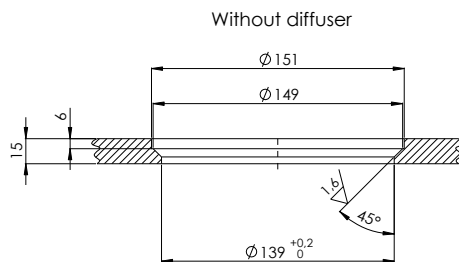
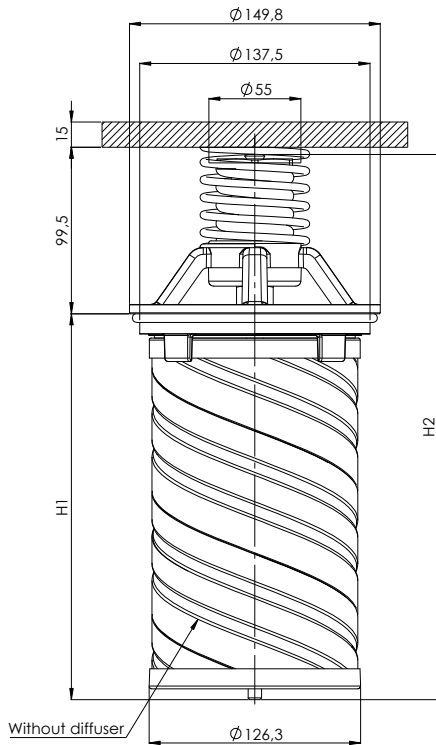

VERSION S

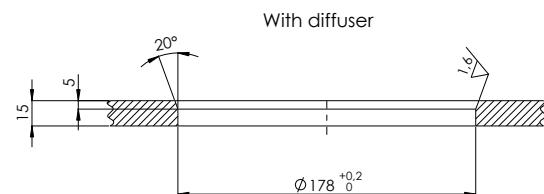
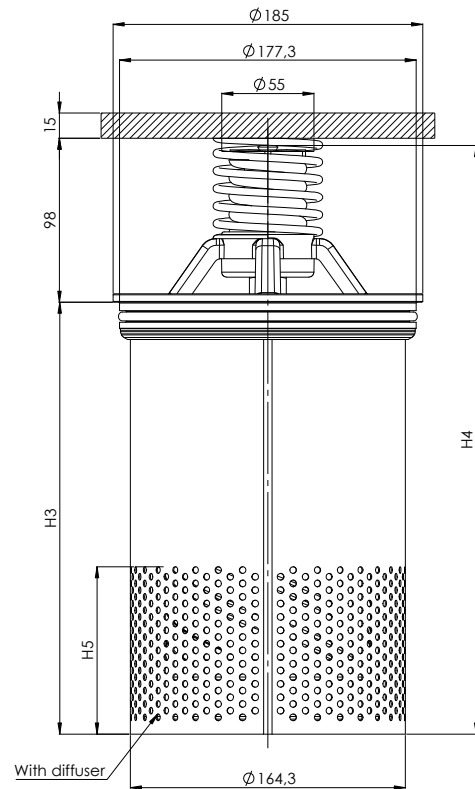

NOMINAL SIZE

MODEL	H1	H2	H3	H4	H5	WEIGHT*	
						Vers. 0	Vers. S
FVR7F-30	230,5	325,5	258	351,5	100	1,5 Kg	2,4 Kg
FVR7F-31	310,5	405,5	338	431,5	100	1,5 Kg	2,7 Kg
FVR7F-33	410,5	505,5	438	531,5	100	1,6 Kg	3,1 Kg
FVR7F-32	500,5	595,5	528	621,5	150	1,6 Kg	3,3 Kg
FVR7F-37	800,5	895,5	828	921,5	150	1,8 Kg	4,5 Kg

* Weight without element and magnets

For more information:

WEB: FLTR.com.au PHONE: (+61) 1300 62 4020 EMAIL: info@FLTR.com.au

FV-R7F-4

VERSION 0

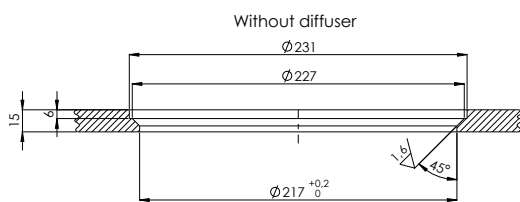
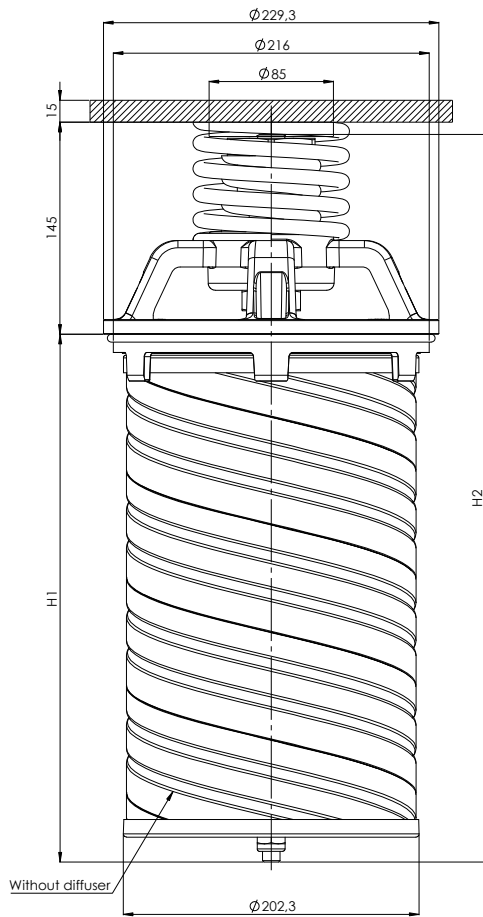

VERSION S

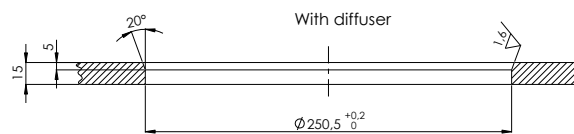
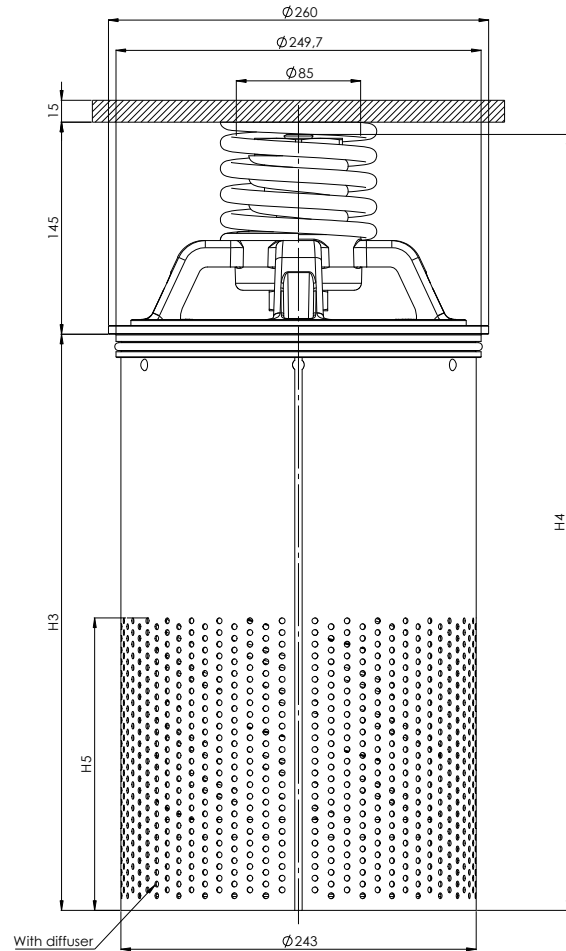

NOMINAL SIZE

MODEL	H1	H2	H3	H4	H5	WEIGHT*	
						Vers. 0	Vers. S
FVR7F-40	361	497,5	394	530,5	150	5,3 Kg	7,8 Kg
FVR7F-41	471	607,5	504	640,5	200	5,5 Kg	8,7 Kg
FVR7F-42	576	712,5	609	745,5	200	5,6 Kg	9,5 Kg
FVR7F-43	856	992,5	889	1025,5	200	6,1 Kg	11,7 Kg
FVR7F-44	1121	1257,5	1154	1290,5	200	6,5 Kg	13,8 Kg

* Weight without element and magnets

For more information:

WEB: FLTR.com.au PHONE: (+61) 1300 62 4020 EMAIL: info@FLTR.com.au

ORDERING INFORMATION

	1.	2.	3.	4.	5.	6.	7.	8.
	FV	R7F	32	G10	B	B	O	O
SPARE ELEMENT	R7F	32	G10	B				

1. FILTER SERIES	FV	
2. FILTER ELEMENT SERIES	R7F	
3. FILTER SIZE	11-12-13-14	
	20-21-22-26	
	30-31-33-32-37	
	40-41-42-43-44	
4. FILTER MEDIA	000	no element
	G03	glassfiber $\beta_{5\mu\text{m(c)}} > 1.000$
	G06	glassfiber $\beta_{7\mu\text{m(c)}} > 1.000$
	G10	glassfiber $\beta_{12\mu\text{m(c)}} > 1.000$
	G15	glassfiber $\beta_{17\mu\text{m(c)}} > 1.000$
	G25	glassfiber $\beta_{22\mu\text{m(c)}} > 1.000$
	G40	glassfiber $\beta_{35\mu\text{m(c)}} > 1.000$
	C10	paper $\beta_{10\mu\text{m(c)}} > 2$
	C25	paper $\beta_{25\mu\text{m(c)}} > 2$
	T60	wire mesh 60 μm
	M05	synthetic $\beta_{10\mu\text{m(c)}} > 1.000$
	M10	synthetic $\beta_{15\mu\text{m(c)}} > 1.000$
	M15	synthetic $\beta_{20\mu\text{m(c)}} > 1.000$
5. SEALS	B	NBR
	V	FKM (on request)
6. BYPASS VALVE	B	1,7 bar
	C	3 bar
		not available for FVR7F4x
7. MAGNETS	0	no magnets
	M	with magnets
8. DIFFUSER	0	no diffuser - no ring
	S	with diffuser - with diffuser ring
	D	with diffuser - no diffuser ring
	W	no diffuser - with ring
		available for FVR7F1x only

PRESSURE DROP (Δp) INFORMATION FOR FILTER SIZING

The max recommended total Δp for return filters is 0,4 – 0,6 bar with clean element.

ELEMENT PRESSURE DROP

The element Δp (bar) is given by the flow rate (l/min) multiplied by the factor in the table here below corresponding to the selected media and divided by 1000.

If the oil has a viscosity V_1 different than 32 cSt a corrective factor $V_1/32$ must be applied.

Example: 600 l/min with R7F32G10B and oil viscosity 46 cSt: $600 \times 0,56 / 1000 \times 46 / 32 = 0,48$ bar

	G03	G06	G10	G15	G25	G40	M05	M10	M15	C10	C25	T60
R7F11	17,12	15,19	6,24	4,77	4,15	2,53	4,70	3,51	2,60	2,95	2,47	0,30
R7F12	10,51	9,73	3,89	3,10	2,79	2,49	3,02	2,70	2,54	2,68	2,38	0,28
R7F13	6,98	6,17	3,35	2,70	2,46	1,93	2,60	2,20	1,97	2,10	1,85	0,22
R7F14	4,97	4,46	2,14	1,96	1,56	1,10	1,66	1,34	1,20	1,22	1,00	0,20
R7F20	3,62	2,95	1,31	1,06	0,97	0,68	1,01	0,88	0,70	0,79	0,60	0,19
R7F21	2,35	1,99	0,98	0,82	0,74	0,51	0,76	0,64	0,56	0,60	0,49	0,12
R7F22	1,67	1,42	0,62	0,48	0,41	0,27	0,47	0,38	0,29	0,34	0,25	0,09
R7F26	1,10	0,95	0,42	0,29	0,25	0,19	0,28	0,24	0,20	0,22	0,17	0,07
R7F30	2,81	2,24	1,21	0,94	0,83	0,54	0,92	0,78	0,63	0,70	0,50	0,13
R7F31	1,85	1,71	0,76	0,49	0,35	0,29	0,47	0,34	0,30	0,33	0,25	0,10
R7F33	1,32	1,11	0,56	0,40	0,32	0,24	0,39	0,31	0,26	0,31	0,20	0,09
R7F32	1,18	1,07	0,44	0,38	0,30	0,21	0,36	0,29	0,24	0,28	0,18	0,08
R7F37	0,59	0,45	0,32	0,28	0,24	0,15	0,26	0,20	0,16	0,18	0,13	0,06
R7F40	0,57	0,42	0,30	0,25	0,20	0,14	0,23	0,19	0,15	0,17	0,12	0,05
R7F41	0,46	0,34	0,25	0,21	0,17	0,12	0,20	0,16	0,13	0,15	0,10	0,04
R7F42	0,33	0,26	0,19	0,17	0,13	0,07	0,15	0,10	0,08	0,09	0,06	0,03
R7F43	0,25	0,20	0,14	0,10	0,08	0,05	0,09	0,07	0,06	0,07	0,04	0,02
R7F44	0,21	0,15	0,11	0,08	0,06	0,02	0,07	0,05	0,03	0,04	0,02	0,01

BYPASS VALVE PRESSURE DROP

The bypass valve Δp is given by the curve of the considered model and setting, in correspondence of the flow rate value.

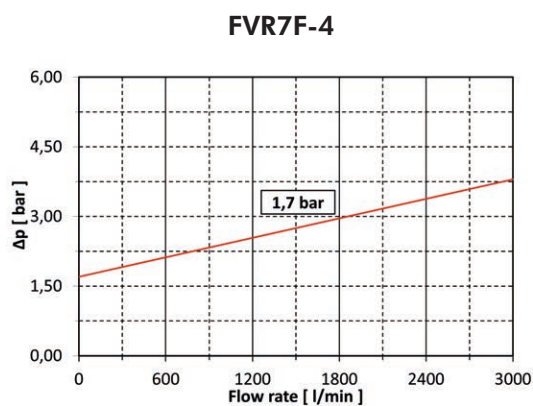
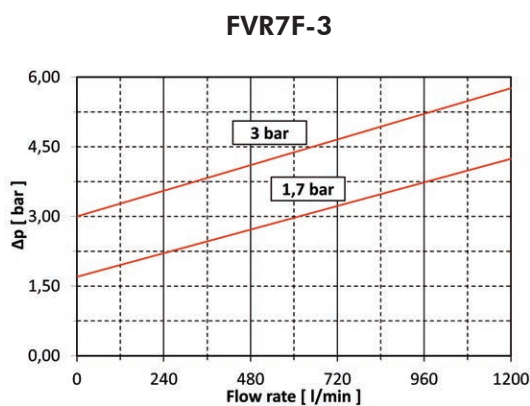
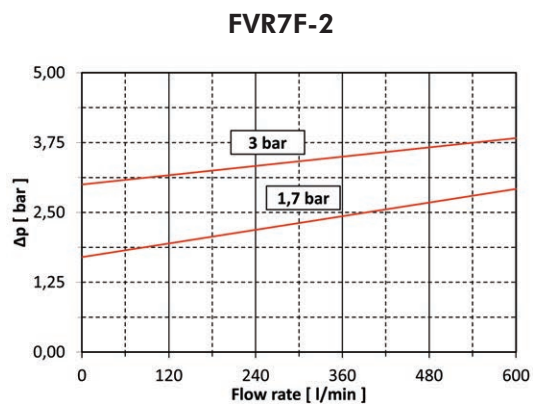
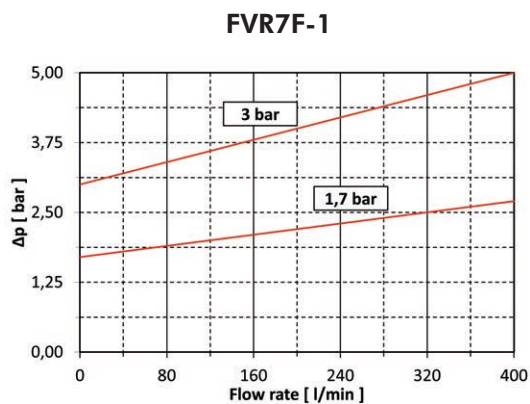

N.B. All the reported data have been obtained at our laboratory, according to specification ISO3968 with mineral oil having 32 cSt viscosity and density 0,875 Kg/dm³.

For more information:

WEB: FLTR.com.au PHONE: (+61) 1300 62 4020 EMAIL: info@FLTR.com.au

USER TIPS



- 1 SPRING
- 2 ELEMENT HOLDER
- 3 GASKETS
- 4 MAGNETS
- 5 FILTER ELEMENT
- 6 FIXING NUT
- 7 DIFFUSER

SPARE SEALS KIT (3)

	NBR	FKM (on request)
FVR7F-1X (version 0)	06.021.00355	06.021.00359
FVR7F-1X (version D)	06.021.00356	06.021.00360
FVR7F-1X (version W)	06.021.00357	06.021.00361
FVR7F-1X (version S)	06.021.00358	06.021.00362
FVR7F-2X	06.021.00363	06.021.00364
FVR7F-3X	06.021.00365	06.021.00366
FVR7F-4X	06.021.00367	06.021.00368

WARNING

- ⚠ Make sure that Personal Protective Equipment (PPE) is worn during installation and maintenance operation.

DISPOSAL OF FILTER ELEMENT

- ⚠ The used filter elements and the filter parts dirty of oil are classified as "Dangerous waste material": they must be disposed according to the local laws by authorized Companies.

INSTALLATION

- ⚠ 1. Make sure that all the filter components are properly mounted as per exploded view directions.
- 2. Enough space must be available for filter element replacement.
- 3. Keep in stock a spare FILTREC filter element for timely replacement when required.
- 4. Filter housing should be earthed.

OPERATION

- ⚠ 1. The filter must work within the operating conditions of pressure, temperature and compatibility given in the first page of this data sheet.
- 2. The filter element must be replaced as soon as the clogging indicator signals at working temperature.
- 3. If no clogging indicator is mounted, replace the element according to the system manufacturer's recommendations.

MAINTENANCE

- ⚠ 1. Before removing the access cover, ensure that the system is switched off and there is no residual pressure in the filter.
- 2. Remove the access cover of the system.
- 3. Remove the spring (1) and extract the filter element assembly.
- ⚠ 4. Warning: a certain quantity of oil can be retained within the filter element, provide to have a proper container available for it.
- 5. Unscrew the nut at the bottom of the insert and slip the dirty filter element carefully.
- 6. Clean the tie rod (and the magnets if present) and check the support gaskets/o-ring (3) conditions, replace them if necessary.
- 7. Fit a new FILTREC element, the spacer and the washer over the tie rod, then screw on it the fixing nut. To achieve the optimal element fitting, tighten the nut until it gets in touch with the washer and the element is stuck; then screw in the nut for one more turn.
- 8. Put the insert assembly into its seat within the tank, put the spring (1) in its position over the element holder (2), then mount the access cover and secure it properly.
- ⚠ 9. The used filter elements cannot be cleaned and re-used.