

KRT SERIES

Tank top return filters

Return filter kits for tank mounting. Filter element with inbuilt bypass valve. Flow rates up to 900 l/min with a wide range of accessories available.



HOUSING	tested according to NFPA T3.10.5.1*, ISO 10771*, ISO 3968
PRESSURE:	Max operating: 8 bar Burst: 16 bar
MATERIALS:	Cover and head: aluminium alloy Bowl: PA6 reinforced Seal: NBR (FKM on request)
BYPASS VALVE:	Inbuilt in the filter element B version 1,7 bar C version 3 bar
ELEMENT	tested according to ISO 11170, 2941, 2942, 2943, 3724, 3968, 16889, 16908, 23181
FILTER MEDIA:	Inorganic microfiber G06 - G10 - G15 - G25 - G40 Paper: C10 - C25 Synthetic: M05 - M10 - M15 Metal wire mesh: T60
COLLAPSE PRESSURE:	10 bar
TEMPERATURE RANGE:	-30°C +100°C
FLUID COMPATIBILITY:	Full with HH-HL-HM-HV HETG-HEES (acc. to ISO 6743/4). For use with other fluid please contact Filtrec Customer Service (info@filtrec.it).

* as reference method only for verifying the pressure fatigue resistance and establishing the burst pressure ratings.

OVERALL DIMENSIONS

CONFIGURATION 0 - NO COVER

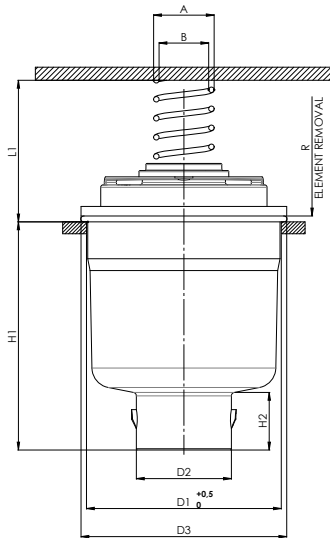

CONFIGURATION 1 & 2 - WITH COVER

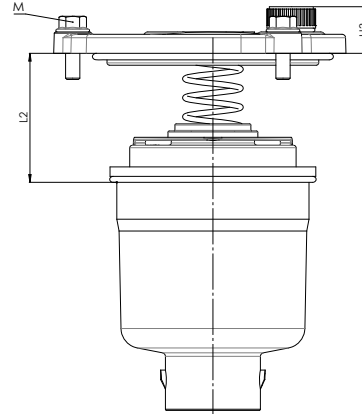

COVER OPTIONS

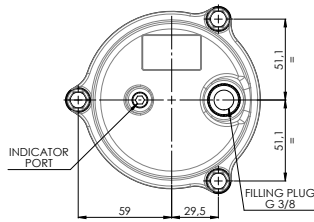

KRT R1 10|11|20|22|30|31

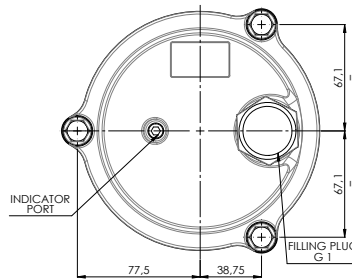

KRT R1 40|43|45

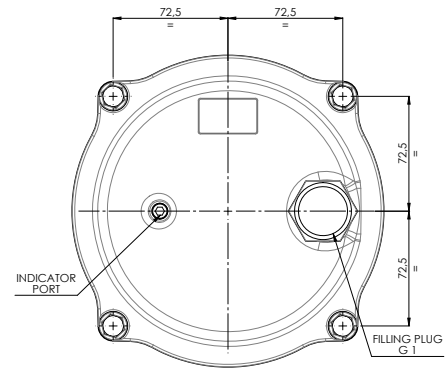

KRT R1 50|51|60|64|66

NOMINAL SIZE

MODEL	A	B	ØD1	ØD2	ØD3	H1	H2	H3	L1	L2	M	R	WEIGHT Kg		
													CONF. 0	CONF. 1	CONF. 2
KRT R1 10			61	24	66,5	85,6	21	20	49,4	54,5		150	0,18	0,31	0,32
KRT R1 11						158,6						220	0,29	0,43	0,44
KRT R1 20	25,5	20,9				96					M6x20	160	0,26	0,46	0,47
KRT R1 22			81	87	141	24	24	59,6	54,3	210		0,36	0,56	0,57	
KRT R1 30					222,5					290		0,56	0,76	0,77	
KRT R1 31					40			326,5				390	0,76	0,96	0,97
KRT R1 40						224						300	0,84	1,30	1,32
KRT R1 43	36,5	31,5	111,5		129	270	30,8	30,8	73,7	69	M8x25	350	1,14	1,60	1,62
KRT R1 45						437						520	1,84	2,30	2,32
KRT R1 50						163						250	0,44	1,31	1,33
KRT R1 51						222						310	0,84	1,71	1,73
KRT R1 60	64,5	56,9	150	65	160	272	39,6	23,5	88,5	85,2	M8x30	360	1,44	2,31	2,33
KRT R1 64						422						510	2,64	3,51	3,53
KRT R1 66															

ORDERING INFORMATION

	1.	2.	3.	4.	5.	6.	7.	8.
	KRT	R1	30	G10	B	B	S	0
SPARE ELEMENT		R1	30	G10	B			

1. FILTER SERIES	KRT	
2. FILTER ELEMENT SERIES	R1	
3. FILTER SIZE	10-11	
	20-22-30-31	
	40-43-45	
	50-51-60-64-66	
4. FILTER MEDIA	000	no element
	G06	glassfiber $\beta_{7\mu\text{m(c)}} \geq 1.000$
	G10	glassfiber $\beta_{12\mu\text{m(c)}} \geq 1.000$
	G15	glassfiber $\beta_{17\mu\text{m(c)}} \geq 1.000$
	G25	glassfiber $\beta_{22\mu\text{m(c)}} \geq 1.000$
	G40	glassfiber $\beta_{35\mu\text{m(c)}} \geq 1.000$
	C10	paper $\beta_{10\mu\text{m(c)}} \geq 2$
	C25	paper $\beta_{25\mu\text{m(c)}} \geq 2$
	T60	wire mesh 60 μm
	M05	synthetic $\beta_{10\mu\text{m(c)}} \geq 1.000$
	M10	synthetic $\beta_{15\mu\text{m(c)}} \geq 1.000$
	M15	synthetic $\beta_{20\mu\text{m(c)}} \geq 1.000$
5. BYPASS VALVE	B	1,7 bar (for paper and wire mesh elements)
inbuilt into the filter element	C	3 bar (for glassfiber elements)
6. SEALS	*B	NBR
* omitted for spare elements	V	FKM (on request)
7. COMPULSORY FIELD	S	standard
8. CONFIGURATION	0	no cover
	1	with cover without filing plug
	2	with cover with filing plug

Continued on the next page

ORDERING INFORMATION

ACCESSORIES

The accessories must be ordered separately

INDICATOR	MPB	press. gauge rear connection	
	MRB	press. gauge radial connection	for "B" bypass
	PDB	pressure switch	
	MPC	press. gauge rear connection	
	MRC	press. gauge radial connection	for "C" bypass
	PDC	pressure switch	
	LC24	LED connector for pressure switch	
EXTENSION TUBE	ET2250	extension tube 250 mm long	(for sizes 20-22-30-31-40-43-45)
	ET2500	extension tube 500 mm long	
	ET4200	extension tube 200 mm long	(for sizes 50-51-60-64-66)
	ET4500	extension tube 500 mm long	
CONNECTION TUBE	CT2250	connection tube 250 mm long	(for sizes 20-22-30-31-40-43-45)
	CT4200	connection tube 200 mm long	(for sizes 50-51-60-64-66)
DIFFUSER	DF040	diffuser Ø 40 mm	(for sizes 20-22-30-31-40-43-45)
	DF065	diffuser Ø 65 mm	(for sizes 50-51-60-64-66)

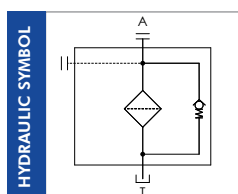

ELEMENT PRESSURE DROP

The element Δp (bar) is given by the flow rate (l/min) multiplied by the factor in the table here below corresponding to the selected media and divided by 1000.

If the oil has a viscosity V_1 different than 32 cSt a corrective factor $V_1/32$ must be applied.

Example: 80 l/min with R130G10B and oil viscosity 46 cSt: $(80 \times 3,19)/1000 \times (46/32) = 0,36$ bar

	G06	G10	G15	G25	G40	C10	C25	T60	M05	M10	M15
R110	33,84	15,68	12,5	8,81	4,54	4,83	4,13	2,56	10,46	8,94	5,58
R111	12,28	7,32	4,48	4,28	2,27	2,74	2,06	0,81	4,79	4,09	2,00
R120	13,85	8,65	6,44	6,32	2,77	4,09	2,52	0,86	5,65	4,83	3,19
R122	7,80	5,27	3,92	3,60	1,55	2,70	1,41	0,76	3,83	3,27	1,79
R130	5,09	3,19	2,25	2,06	0,90	1,64	0,82	0,49	2,31	1,98	1,02
R131	3,34	1,94	1,37	1,26	0,46	1,06	0,42	0,24	1,41	1,20	0,63
R140	2,43	1,31	1,25	1,10	0,43	0,85	0,39	0,22	0,95	0,82	0,62
R143	2,25	1,21	1,15	1,00	0,39	0,83	0,35	0,20	0,88	0,75	0,57
R145	1,35	0,55	0,52	0,50	0,17	0,42	0,22	0,10	0,52	0,44	0,32
R150	2,16	1,12	1,08	0,96	0,37	0,82	0,34	0,19	0,81	0,69	0,54
R151	1,80	0,88	0,77	0,71	0,29	0,64	0,26	0,15	0,64	0,55	0,38
R160	1,49	0,74	0,71	0,51	0,25	0,45	0,23	0,10	0,54	0,46	0,35
R164	1,32	0,52	0,45	0,42	0,13	0,36	0,12	0,10	0,38	0,32	0,21
R166	0,80	0,43	0,34	0,24	0,11	0,20	0,10	0,06	0,22	0,20	0,18

BYPASS VALVE PRESSURE DROP

The bypass valve Δp is given by the curve of the considered model and setting, in correspondence of the flow rate value.

KRT R1 10-31

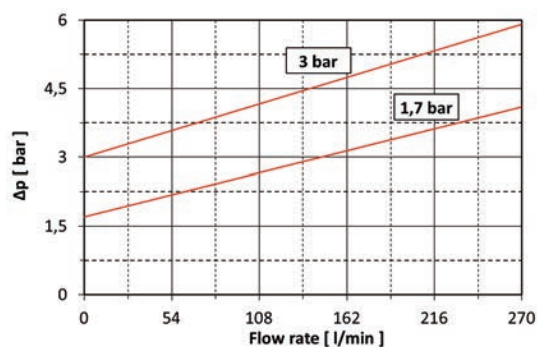

KRT R1 40-66

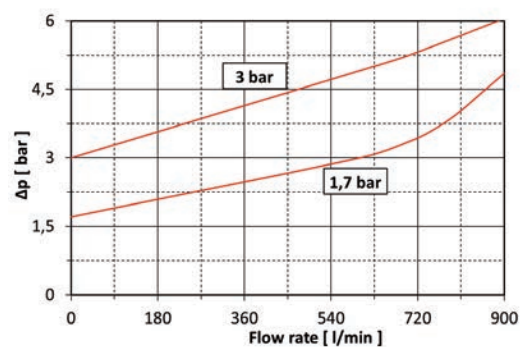

ACCESSORIES

These accessories must be ordered separately; they fit all our models except sizes 10-11.



A EXTENSION TUBE

The flow from the filter must come out below the oil level to avoid possible generation of free air or foam. When necessary an extension tube can be fitted onto the knobs of the bowl end.

for size 20 to 45

06.016.00267	ET2250	extension tube 250 mm long
06.016.00268	ET2500	extension tube 500 mm long

for size 50 to 66

06.016.00355	ET4200	extension tube 200 mm long
06.016.00356	ET4500	extension tube 500 mm long

B CONNECTION TUBE

Connection tube is the necessary device between filter bowl and extension tubes (ET2250 / ET2500 / ET4200 / ET4500) and/or diffuser (DF040 / DF065). Its plug and play option makes it easy to install and versatile.

for size 20 to 45

06.016.00352	CT2250	connection tube 250 mm long
--------------	--------	-----------------------------

for size 50 to 66

06.016.00358	CT4200	connection tube 200 mm long
--------------	--------	-----------------------------

C DIFFUSER

Diffuser is an effective way to reduce foaming and turbulence normally caused by return lines. Plug and play option to be directly installed on the filter bowl or to connection tube (CT2250/CT4200). Installation of a diffuser in the hydraulic tank is an easy way to ensure the reliability of the overall system.

Diffuser must always be installed below the minimum oil level.

for size 20 to 45

06.016.00361	DF040	diffuser Ø 40 mm
--------------	-------	------------------

for size 50 to 66

06.016.00362	DF065	diffuser Ø 65 mm
--------------	-------	------------------

USER TIPS



SPARE SEALS KIT (6)

	NBR	FKM
KRT-R1-10/11-S0	06.021.00458	06.021.00459
KRT-R1-10/11-Sx	06.021.00460	06.021.00461
KRT-R1-20/22/30/31-S0	06.021.00462	06.021.00463
KRT-R1-20/22/30/31-Sx	06.021.00464	06.021.00465
KRT-R1-40/43/45-S0	06.021.00466	06.021.00467
KRT-R1-40/43/45-Sx	06.021.00468	06.021.00469
KRT-R1-50/51/60/64/66-S0	06.021.00470	06.021.00471
KRT-R1-50/51/60/64/66-Sx	06.021.00472	06.021.00473

COVER SCREW TIGHTENING TORQUE

M6 - for size 10 to 31	10 Nm
M8 - for size 40 to 66	25 Nm

INDICATOR TIGHTENING TORQUE

10 Nm

WARNING

- ⚠ Make sure that Personal Protective Equipment (PPE) is worn during installation and maintenance operation.

DISPOSAL OF FILTER ELEMENT

- ⚠ The used filter elements and the filter parts dirty of oil are classified as "Dangerous waste material": they must be disposed according to the local laws by authorized Companies.

INSTALLATION

- The filter bowl (2) should be preferably mounted downward.
- ⚠ The OUT port must be clear (an extension tube could be fitted, if needed for having the outlet below the oil level), at least it's suggested the diffuser.
- Verify that no tension is present on the filter after mounting.
- Enough space must be available for filter element replacement.
- The visual clogging indicator must be in an easily viewable position.
- When an electrical indicator is used, make sure that it is properly wired.
- Keep in stock a spare FILTRAC filter element for timely replacement when required.
- Filter housing should be earthed.

OPERATION

- ⚠ The filter must work within the operating conditions of pressure, temperature and compatibility given in the first page of this data sheet.
- The filter element must be replaced as soon as the clogging indicator signals at working temperature.
- If no clogging indicator is mounted, replace the element according to the system manufacturer's recommendations.

MAINTENANCE

- ⚠ Before removing the top cover from the tank, ensure that the system is switched off and there is no residual pressure in the filter.
- Unscrew the fixing bolts of the top cover and remove it.
- Remove the spring (4) first, then the dirty element (3) and the bowl (2).
- Clean the bowl (2) and fit a new FILTRAC element (3), verifying the part number, particularly concerning the micron rating.
- When fitting the new element (3), open its plastic protection on the open end side and insert it onto the spigot in the filter bowl, then remove completely the plastic protection.
- Check the top cover O-ring conditions and replace if necessary.
- Put the spring (4) in its position on the filter element (3).
- Mount the top cover onto the tank and fix it screwing the fixing bolts.
- ⚠ The used filter elements cannot be cleaned and re-used.